

This manual contains preliminary servicing instructions for the Poseidon breathing regulators. It is intended to serve as a guide for repairs and servicing carried out by Poseidon Diving Systems. The instructions given in this manual are based on the assumption that special tools are used and are based on our experience. The work should be done in the same order as shown in these instructions.

#### **TYPE DESIGNATIONS:**

In all correspondence concerning breathing regulators, indicate the type designation and serial number. All products in this servicemanual that requires a CE-approval are of course CE-approved. CE approval represents only a minimum level of product quality and manufacturing standards. At Poseidon we put each new addition through rigorous testing procedures ourselves. This is the only proper method to ensure that your equipment will live up to our claims.

#### **CLEANING:**

If corrosion or salt deposits occurs, place all metal parts – concentrated Hempodid\* or 15% Hydrochloric acid for about 10 minutes. Then, rinse the parts thoroughly and blow dry with air. The synthetic parts in the second stage must not be treated with solvent. They shall be cleaned in freshwater only.

*\*Hempodid = Acid Liquid Detergent Containing phosphoric acid (5 - 10%) and bactericid for disinfectant cleaning.*

#### **FOLLOWING LUBRICATE IS USED:**

##### **Grease:**

Gleitmo 594 Art no 8507

Siliconpasta Art no 2587

##### **Oil:**

Siliconoil Art no 3139

## FUNCTION

POSEIDON breathing regulator is a two-stage regulator where the first stage is a diaphragm-actuated reducing valve, which reduces the primary pressure (Cylinder pressure) to approx. 145 PSI. The reduced pressure (the secondary pressure) then goes via the regulator hose to the second stage where the air supply is automatically regulated to the convenience of the diver.

The first-stage always holds the adjusted pressure above the ambient pressure which is necessary to the function of the breathing regulator. This is brought about, the outer springloaded diaphragm being in contact with the ambient pressure. It automatically responds to this pressure acting it and thereby regulates all changes in pressure.

During diving in cold water, i.e, temperatures lower than +6°C (+43°Fahrenheit ), the outer spring housing of the first stage may be provided with an anti-freeze cap in order to prevent direct contact with the water. This is necessary as the considerable cooling that takes place when the primary air expands in the secondary chamber can otherwise cause ice to form and thereby prevent the springs and diaphragm from functioning.

The second-stage functions in such a way that the underpressure created in the regulator housing during each inhalation influences a diaphragm actuated valve system, which will supply the necessary air as long as the inhalation phase lasts. The automatic pressure compensation takes place in the same way as in the first stage, the outer diaphragm surface being in direct contact with ambient pressure, and the pressure on the inside of the diaphragm must correspond to ambient pressure before the diaphragm can return to its position. The diaphragm returns to its rest position and shuts off the air flowing in as soon as the inhalation phase has been broken off and the air pressure in the regulator housing has become equal to ambient pressure.

The second stage has been provided with an ejector system for the purpose of keeping inhalation effort to a minimum.

During the exhalation phase, the exhaled air goes out through the exhalation diaphragm on the opposite side of the inhalation diaphragm into the ambient medium. The exhalation diaphragm closes automatically when exhalation stops. Also, the exhalation diaphragm regulates the necessary pressure compensation by closing when the ambient pressure is equal. The special construction of the exhalation section of the regulator has been designed to obtain high capacity with low exhalation effort.

The second stage has a built in purge button, for manual purging.

## FAULT-TRACING SCHEME

This fault-tracing scheme is primarily intended to serve as a guide during servicing. It contains probable faults and remedies aimed at facilitating servicing work.

<b>FAULT</b>	<b>PROBABLE REASONS</b>	<b>REMEDIES</b>
<b>First stage valve connection leaks</b>	Connections not tightened	Tighten up
	O-rings or sealing surface defective	Replace o-rings. Replace defective parts
<b>First stage secondary side leaks</b>	The cover is not tightened	Tighten up
	Diaphragm defective	Replace diaphragm
<b>Safety valve activates</b>	O-ring defective or not lubricated	Replace o-ring and lubricate
	First stage leaks or is adjusted to high	Repair first stage  Adjust secondary pressure
	Sealing surface defective	Replace low pressure valve housing or low pressure hose
<b>Second stage valve takes in water</b>	Diaphragm defective	Replace diaphragm
	Mouth-piece cracked	Replace mouth-piece
	O-ring not fitted or defective	Fit or replace o-ring
	Foreign object under exhalation diaphragm	Clean

**FAULT****PROBABLE  
REASONS****REMEDIES**

*(from the foregoing page)*

**Second stage valve takes  
in water**

The switch defective

Replace the switch

The o-ring under the  
switch is defective

Replace the o-ring.

---

**Second stage valve leaks air  
(regulator freeflows)**

Servo valve leaks

Replace servo valve

Sleeve in low pressure  
valve defective

Replace valve insert

Filter in valve insert  
is clogged

Replace valve insert

Valve tube incorractly  
adjusted

Adjust

Purge button deformed

Replace purge button

---

**Second stage valve  
inhalation resistance too high**Valve needle in servo valve  
defective

Replace servo valve

Diaphragm defective

Replace diaphragm

Valve tube incorractly  
adjusted

Adjust

FAULT	PROBABLE REASONS	REMEDIES
<i>(from the foregoing page)</i>		
<b>Second stage valve provides no air when purge button is activated</b>	Valve tube incorrectly adjusted	Adjusted
	Spring in purge button defective	Replace purge button
<b>Exhalation resistance too high</b>	Diaphragm. stuck	Clean or replace diaphragm
<b>Air flow restricted</b>	Filter in first stage valve clogged	Replace filter
	Low pressure from first stage	Adjust pressure
<b>Inhalation resistance is not altered when the switch is set at minus</b>	Diaphragm cam is deformed or wrongly fitted	Fit a new switch

## BLIND SCREWS WITH DIFFERENT THREADS

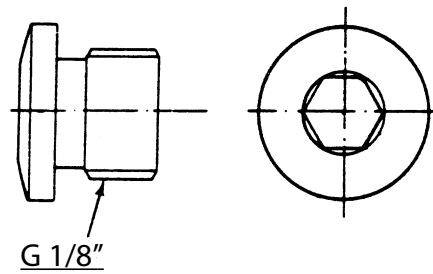
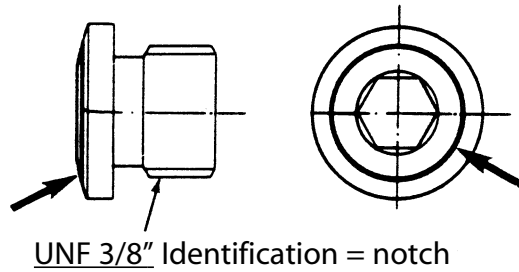

## LOW PRESSURE HOSE WITH DIFFERENT THREADS

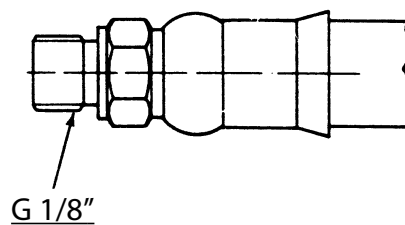
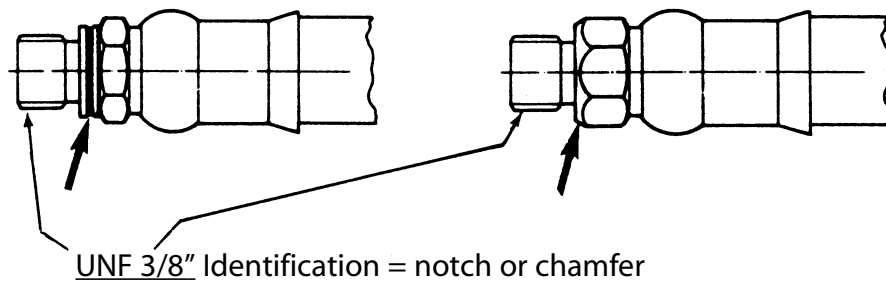

## **Poseidon Jetstream**

### **BREATHING REGULATOR**

#### **Art. No 2960**

USA: Poseidon Odin

Primary pressure.....	Max. 4350 PSI / 300 bar
Secondary pressure .....	Max. 145 PSI 10 bar
Air flow .....	Approx. 1600 l/min
Inhalation resistance .....	Max. 40 mm of water
Exhalation resistance .....	Max. 20 mm of water

*The above data apply when measuring at atmospheric pressure*

### **FIRST STAGE VALVE**

#### **Art. No 2962, 3580**

Description.....	Diaphragm- actuated balanced with shear venturi boost.
Connecting threads for primary pressure.....	G5/8" -max. 4350 PSI/ 300 bar accord. SS 2600/K and DIN 477/5 or yoke connection accord. SS 2603 and ANSI/CGA V1: 1987

Outlet connections:

One outlet marked R for second stage (max. airflow) .....	UNF 3/8" -secondary pressure
Three outlets marked LP for drysuits, buoyancy compensators, hookah supply safety second stage,etc .....	UNF 3/8"-secondary pressure
One outlet marked S has restricted airflow and therefore is intended only for dry-suit or stabjacket .....	Intended for first stage No 3580 UNF 3/8"-secondary pressure
One outlet marked HP for pressure gauge.....	UNF 7/16"- primary pressure

### **SECOND STAGE VALVE**

#### **Art. No. 2961, 3546**

Description.....	Upstream diaphragm actuated. servo assisted with safety relief, fixed ejector system. Purge button for clearing. Sensitivity switch for added control.
------------------	---

### **REGULATOR HOSE WITH INTEGRAL SAFETY VALVE**

Length.....	28 inch / 70 cm
Release pressure .....	Approx. 247 PSI / 17 bar

### **TIGHTENING TORQUE**

Primary connection .....	20 - 22 lbf.ft / 28 - 30 Nm
Valve cover .....	20 - 22 lbf.ft / 28 - 30 Nm
Connections marked R-LP-HP .....	6 lbf.ft / 8 Nm
Balanced housing .....	7 lbf.ft / 10 Nm

### **ANTI-FREEZE PROTECTION**

Type designation .....	Art. No 1286
Type .....	Rubber cap

## **Poseidon Jetstream**

### **BREATHING REGULATOR**

**Art. No 3960**

Primary pressure .....	Max. 4350 PSI / 300 bar
Secondary pressure .....	Max. 145 PSI / 10 bar
Air flow .....	Approx. 1600 l/min
Inhalation resistance .....	Max. 40 mm of water
Exhalation resistance .....	Max. 20 mm of water

*The above data apply when measuring at atmosphere*

### **FIRST STAGE VALVE**

**Art. No 3790, 3790 10**

Description.....	Diaphragm-actuated balanced with shear venturi boost. Release pressure approx. 217-247 PSI / 1,5-1,7 MPa / 15-17 bar
Connecting threads for primary pressure.....	G 5/8" -max 4350 PSI /30 MPa /300 bar accord. SS 2600/K and DIN 477/5 or yoke connection accord. SS 2603 and ANSI/CGA V1: 1987

Outlet connections:

One outlet marked R for second stage (max. airflow).....	UNF 3/8" - secondary pressure
Three outlets marked LP for Jetstream octopus, drysuits, stadjacket.....	UNF 3/8" -secondary pressure
Two outlets marked HP for pressure gauge.....	UNF 7/16" -primary pressure

### **SECOND STAGE VALVE**

**Art. No. 2961, 3546**

Description.....	Upstream diaphragm actuated. servo assisted with safety relief, fixed ejector system. Purge button for clearing. Sensivity switch for added control.
------------------	--

### **REGULATOR HOSE WITH INTEGRAL SAFETY VALVE**

**Art. No 2943**

Length.....	28 inch / 70 cm
Release pressure .....	Approx. 247 PSI/17 bar

### **TIGHTENING TORQUE**

Primary connection, valve cover .....	22 lbf.ft / 30 Nm / 3,0 kpm
Connections marked R-LP-HP .....	6 lbf.ft / 8 Nm / 0,8 kpm

### **ANTI-FREEZE PROTECTION**

Type designation .....	Art. No 1286
Type .....	Rubber cap



## **Poseidon Oceanair**

### **BREATHING REGULATOR**

#### **Art. No 2940**

USA: Poseidon Thor

Primary pressure .....	Max. 4350 PSI / 300 bar
Secondary pressure .....	Max. 181 PSI / 12.5 bar
Air flow .....	Approx. 1500 l/ min
Inhalation resistance .....	Max. 40 mm of water
Exhalation resistance .....	Max. 20 mm of water

*The above data apply when measuring at atmospheric pressure*

### **FIRST STAGE VALVE**

#### **Art. No 3020**

Description.....	Diaphragm-operated, compensated
Connection threads for primary pressure .....	G 5/8" -max 4300 PSI / 300 bar accord. SS 2600/K and DIN 477/4

Outlet connections:

Four outlets marked LP for second stage, drysuits, hookah supply, safety second stage, etc .....	UNF 3/8" -secondary pressure
One outlet marked HP for pressure gauge.....	UNF 7/16"-primary pressure

### **SECOND STAGE VALVE**

#### **Art. No. 2961, 3546**

Description.....	Upstream diaphragm actuated. servo assisted with safety relief, fixed ejector system. Purge button for clearing. Sensitivity switch for added control.
------------------	---

### **REGULATOR HOSE WITH INTEGRAL SAFETY VALVE**

Length.....	28 inch / 70 cm
Release pressure .....	Approx. 247 PSI/ 17 bar

### **TIGHTENING TORQUE**

Primary connection .....	20-22 lbf.ft 28 Nm
Valve cover .....	20-22 lbf.ft 28 Nm
Connections marked LP-HP.....	6 lbf.ft / 8 Nm

### **ANTI-FREEZE PROTECTION**

Type designation .....	Art. No 1286
Type .....	Rubber cap

# REPAIR INSTRUCTIONS SECOND STAGE DEMAND VALVE

## EXPLODED VIEW

Art. No. 2725, 2941, 2961, 3546

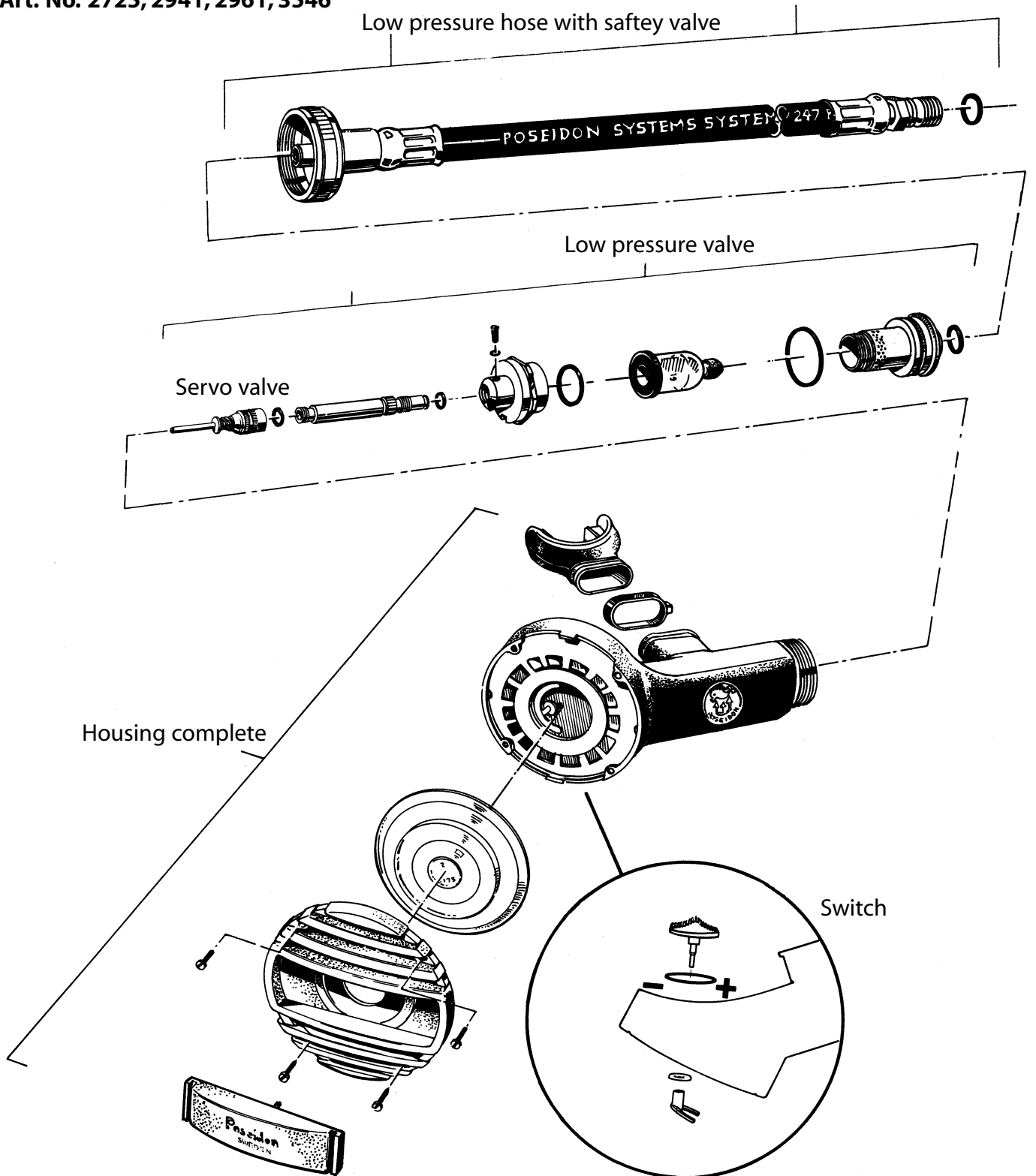

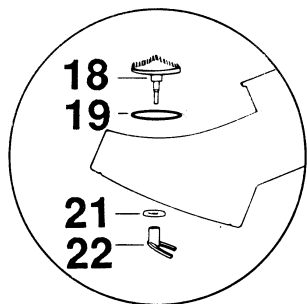
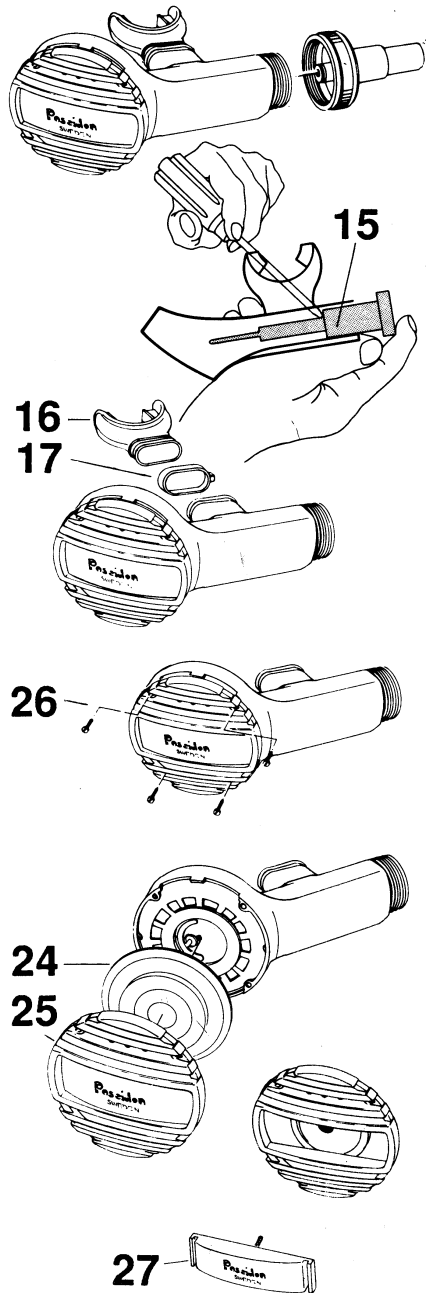

## SECOND STAGE 2710, 2941, 2961, 3546

### Removal:

1. Disconnect the low pressure hose from the second stage.
2. Remove the low pressure valve from the housing (15) with a screwdriver. Make sure the servo valve needle is not bent. Be sure to hold the low pressure valve carefully, to avoid dropping it (see figure).
3. Cut off the locking strap (17) with cutting pliers. Remove the mouth piece (16).
4. Unscrew the 4 screws (26) with a 3.5 mm screwdriver.
5. Remove the cover (25) and the diaphragm (24).
6. Remove the purge button (27).

### IMPORTANT

**The switch should not be removed if it is undamaged.**

### Removal:

1. Pull out the diaphragm cam (22).
2. Cut off the switch (18) with a pair of cutting pliers close to the locking washer (21). Remove the switch.
3. Remove the o-ring (19).

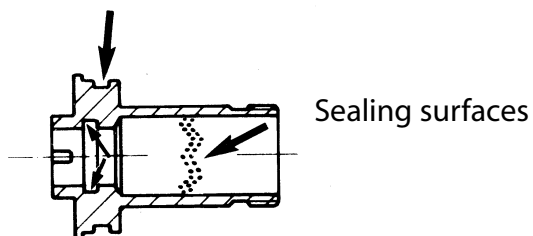
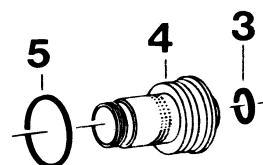
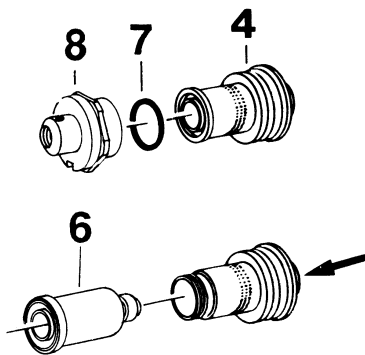
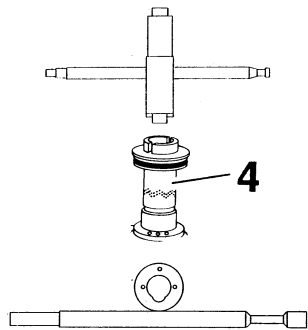
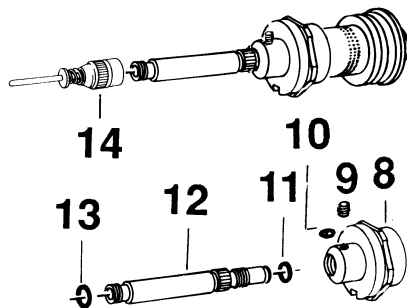

## Removal:

1. Remove the servo valve (14).
2. Unscrew the stop screw (9) and remove the valve tube (12). Remove the o-rings (11) (13) with an o-ring remover. Make sure the sealing surfaces are not damaged.
3. Remove the rubber plate (10).
4. Place the valve housing in the tool. Unscrew the valve housing (4) with a special spanner.
5. Remove the o-ring (7) with an o-ring remover. Make sure the sealing surfaces are not damaged.
6. Remove the valve insert.
7. Remove the o-rings (5) (3) with an o-ring remover. Make sure the sealing surfaces are not damaged.

When servicing the regulator the following parts should be replaced: See chapter Servicekit.

1. All o-rings. Also the ones in the low pressure hose.

### CLEANING:

If corrosion or salt deposits occurs, place all metal parts – concentrated Hempodid\* or 15% Hydrochloric acid for about 10 minutes. Then, rinse the parts thoroughly and blow dry with air. The synthetic parts in the second stage must not be treated with solvent. They shall be cleaned in freshwater only.

*\*Hempodid = Acid Liquid Detergent Containing phosphoric acid (5 - 10%) and bactericid for disinfectant cleaning.*

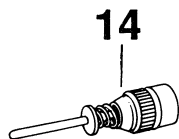
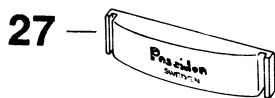
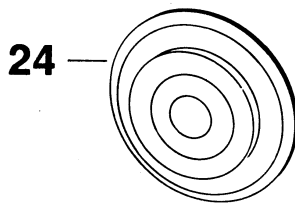

### BEFORE INSTALLING CHECK THE FOLLOWING:

1. Diaphragm (24). Check that the sealing surface of the diaphragm is even. Also check that there are no holes in the diaphragm and that the diaphragm washer is properly fixed in position.
2. The mouth-piece (16). Make sure there are no cracks.
3. The purge button (27). Make sure there are no cracks. Check to make sure the spring is undamaged.
4. Servo valve (14). Check to make sure that the valve bar is not bent.
5. The switch: Put the switch into - and +position. It should be moved rather slowly, control the position of the diaphragm and that it is properly tighten.

## SECOND STAGE

### Assembly:

1. Mount the o-rings (5,3) on the valve housing (4). Use the tools. See diagram.

2. Install the valve insert (6) in the valve housing (4).

3. Place the o-ring (7) in the groove of the valve insert (6). Lubricate the thread. Install the valve housing nut (8).

4. Place the valve housing in the handle. Tighten with a tool. See diagram.

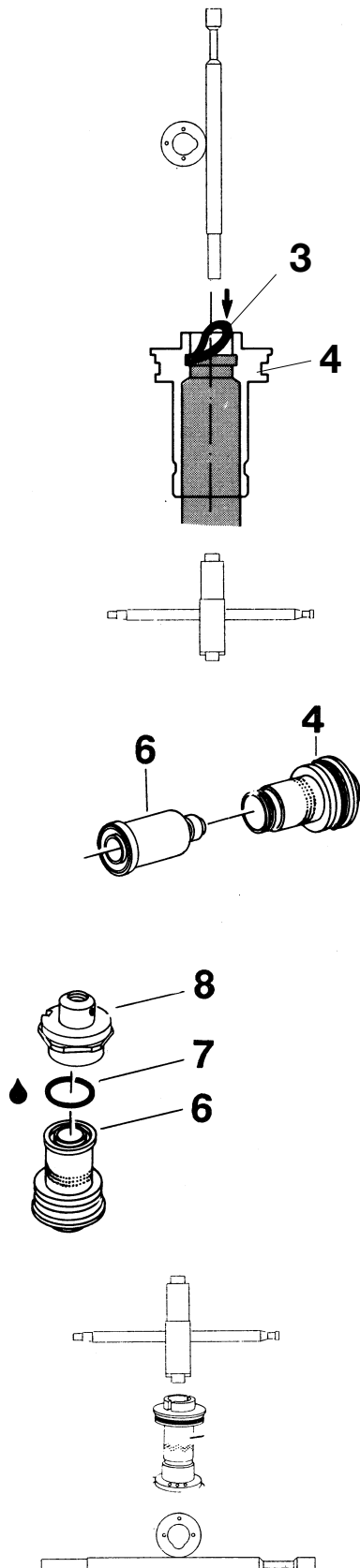

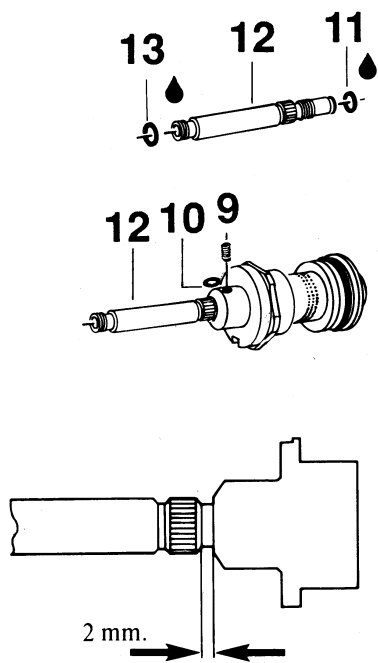

5. Install the o-rings (11,13) on the valve tube (12). Grease the threads and the o-rings.
6. Screw in the valve tube (12) until about 2 mm space remains as illustrated.
7. Install the rubber plate (10). Screw in the set screw (9). Do not tighten up.
8. Screw the servo valve (14) on to valve tube (12). Tighten up. Be careful not to bend the valve needle.
9. Test the low pressure valve for leakage. See chapter: Final adjustment.

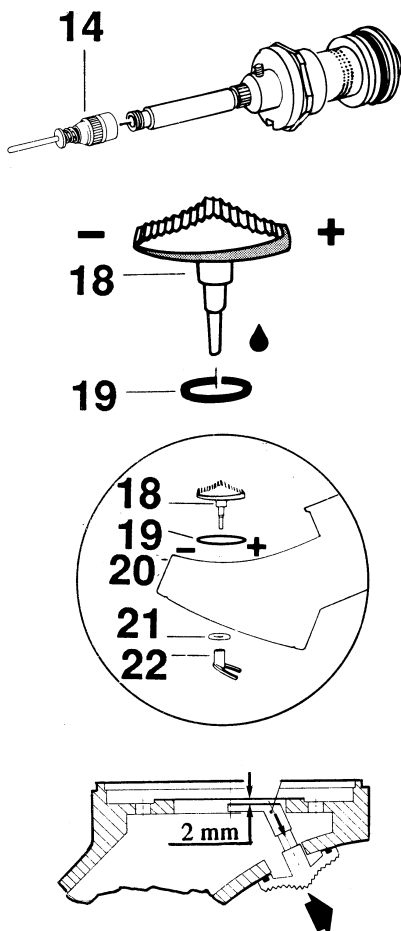

## SWITCH

1. Fit in o-ring (19) and lubricate it.
2. Fit in the switch with the narrow part against the - minus sign on the second stage valve. See diagram.
3. Install the locking washer (21) on the switch (18). Press it on a drift. Tighten the locking washer so that there is sufficient resistance when setting the switch.
4. Fix the diaphragm cam (22) upon the switch (18). Set switch at - (minus), press the diaphragm cam into correct position per the diagram.

The distance from the top of the diaphragm cam to the housing should be 2 mm, concerns diaphragm of silicone rubber, see diagram. Carefully push diaphragm cam into the right position. Note the cam should be pushed slowly on to the switch so that the switch is not moved.

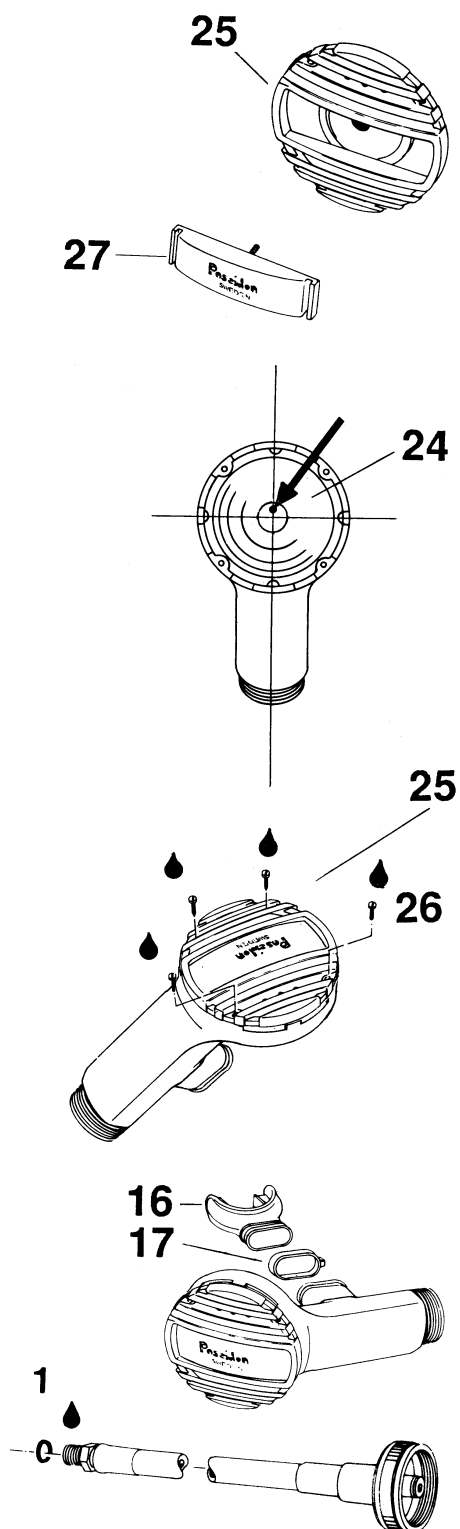

### Assembly:

1. Fit the purge button in the cover (25) for the second stage. Make sure that the spring is undamaged.
2. Position the diaphragm (24) with the diaphragm washer facing down wards and the hole positioned as illustrated.
3. Position the cover (25) for the second stage according to the adjacent illustration. Lubricate the screw and tighten (27) with a screwdriver.
4. Install the mouth piece (16) and the locking strap (17). Tighten up and cut off with plastic band pliers.
5. Checking the second stage for leaks: Place the mouth piece against your lips and cover the low pressure hose connection with your thumb and inhale lightly. This will create a partial vacuum inside the second stage. If the pressure does not equalize in 5 second stage leaks. See chapter fault detecting.

### LOW PRESSURE HOSE WITH SAFETY VALVE

Check the hose for cracks or other defects. Check the sealing surfaces and threads.

Install the o-ring (1) and lubricate it.

Install the hose in the outlet of the first stage valve marked R (important for the regulators performance). Tighten with 13 mm open- end wrench. Oceanair in an optional outlet marked LP.



# REPAIR INSTRUCTIONS FIRST STAGE REDUCING VALVE

EXPLODED VIEW

Art. No. 2801, 2808, 2962, 3257, 3580, 3585

JETSTREAM - YOKE

CYKLON 5000 - YOKE

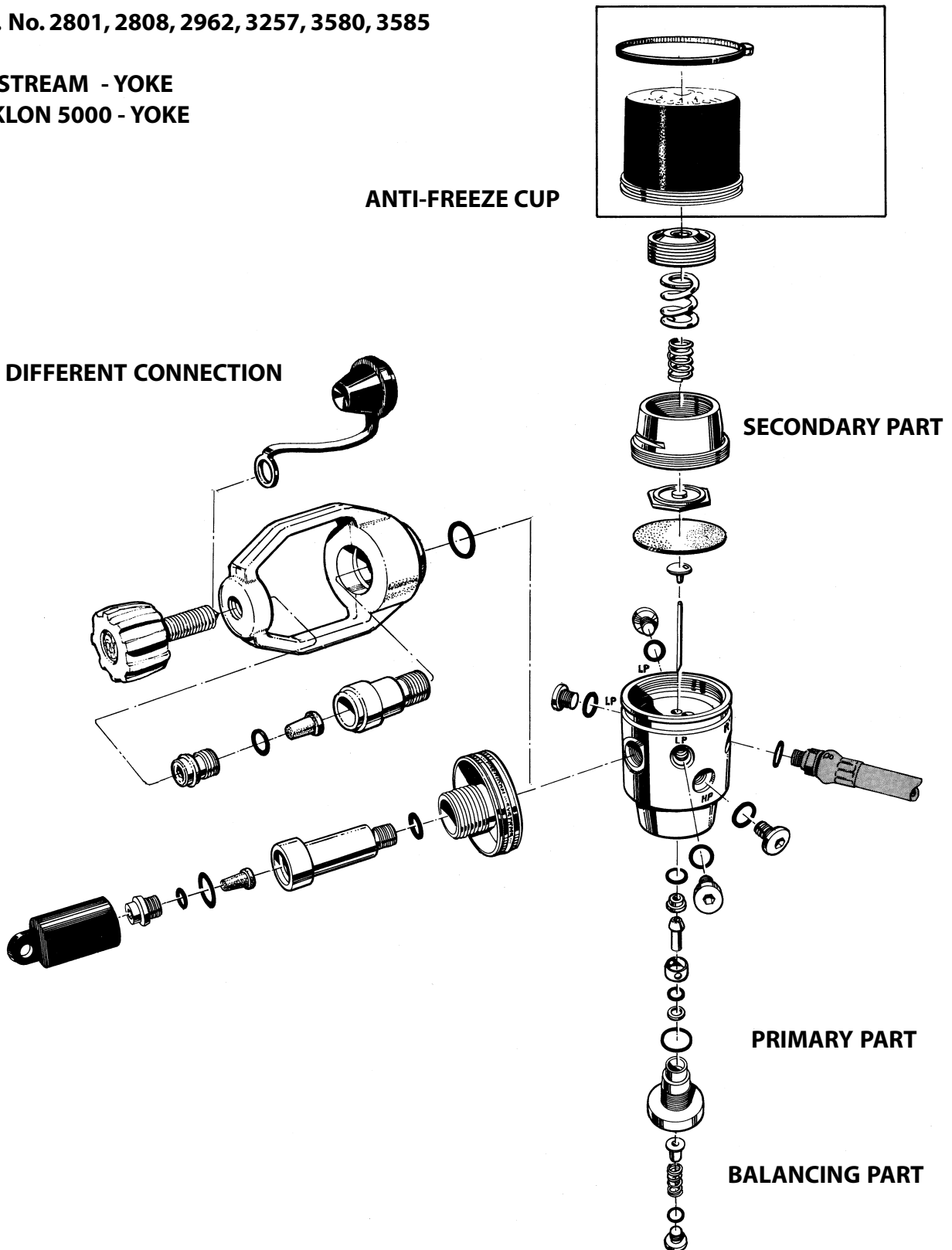

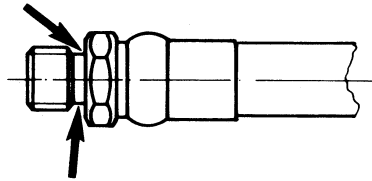

## FIRST STAGE VALVE 2801, 2808, 2962, 3257, 3580, 3585

### Secondary side:

1. Disconnect the low pressure hose from the first stage valve using a 13 mm open end wrench.
2. Remove the o-ring from the low pressure hose. Make sure the sealing surfaces are not damaged.

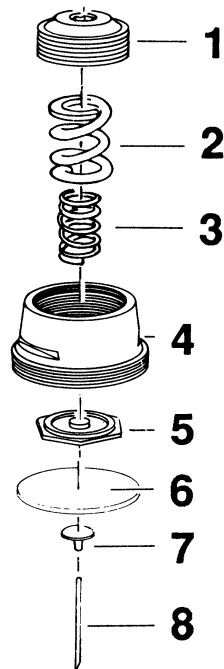
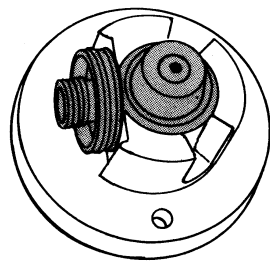

### Removal:

Place the first stage valve with the secondary side facing upwards in the fixture.

1. Remove the pressure adjusting screw (1) with a 6 mm Allen wrench and remove the spring (2) and (3).
2. Remove the cover (4) using a 27 mm crowsfoot and the upper diaphragm centre (5).
3. Remove the diaphragm (6). Make sure the sealing surface is not damaged. Remove the lower diaphragm centre (7) and the valve needle (8).

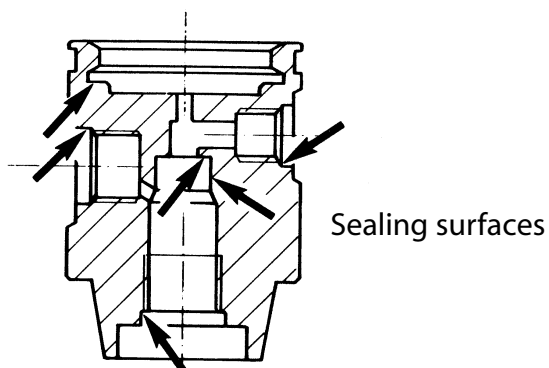

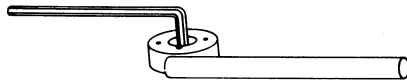

## BALANCE HOUSING

### Removal:

Place the first-stage valve with the balanced housing facing upwards.

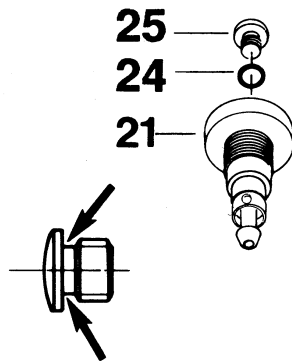

1. Steady the balance housing with a special wrench. Then remove the blind screw (25) with a 5 mm Allen wrench. Remove the o-ring (24) with an o-ring remover. Remove the balance housing (21) with the special wrench.

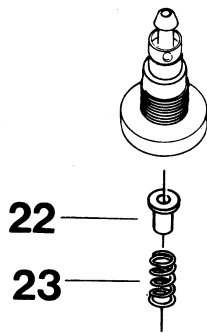

2. Remove the spring (23) and the spring guidance (22).

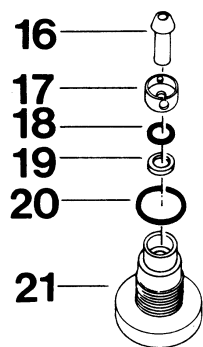

3. Remove the valve piston (16) and the spacing sleeve (17). Remove the o-ring (18) with an o-ring remover. Remove the washer (19) and the o-ring (20). Use an o-ring remover for this also. Make sure the sealing surfaces are not damaged.

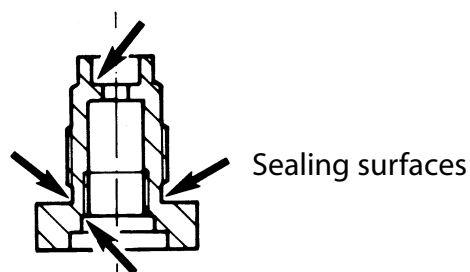

## FIRST STAGE 2962, 3257, 3580, 3585

### Removal:

1. Remove the protective cap (26).
2. Remove the locking screw (27) with a 6 mm Allen wrench. Remove the o-ring (28) and the cupfilter (30).
3. Place the first stage in the fixture. Remove the connecting (31) with a 6 mm Allen wrench.
4. Remove the wheel (33) and the oring (32) with an o-ring remover. Make sure the sealing surfaces are not damaged.

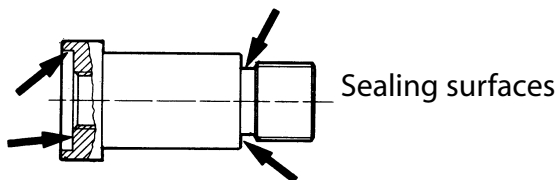
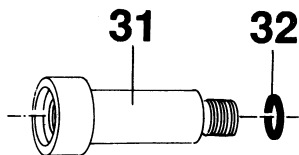
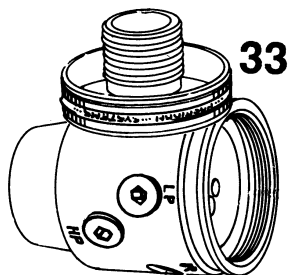
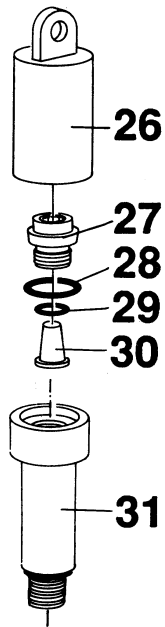

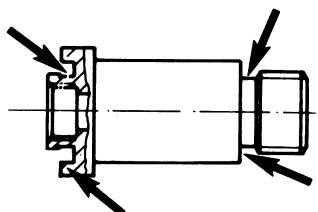
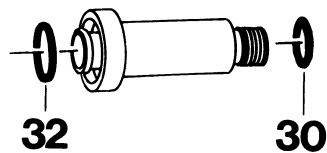
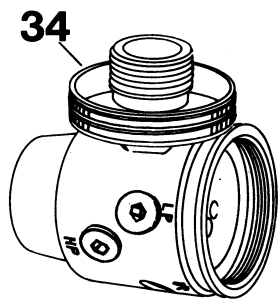
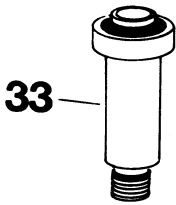
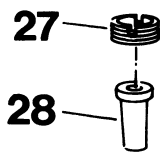
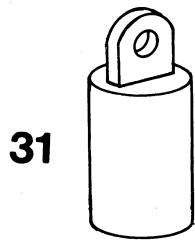

Sealing surfaces

## FIRST STAGE 2801

### Removal:

1. Remove the protective cap (31).
2. Remove the locking screw (27) with an 8.5 mm screwdriver. Remove the cup filter (28).
3. Place the first stage in the fixture. Remove the high pressure valve housing (33) with a 6 mm Allen wrench.
4. Remove the wheel (34).
5. Remove the o-rings (30,32) with an o-ring remover. Make sure the sealing surfaces are not damaged.

## FIRST STAGE 2801, 3257 10, 3585 10

### Removal:

1. Remove the protective cap (24).  
Unscrew the knob (25).

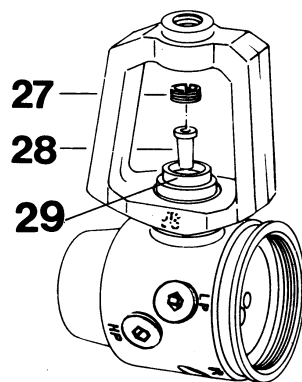
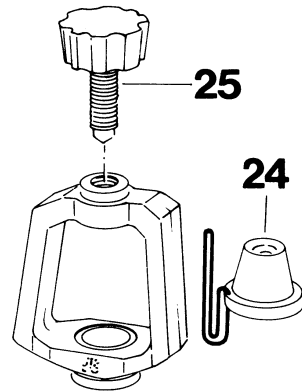

2. Remove the locking screw (27)  
with an 8.5 mm screwdriver.  
Remove the cup filter (28).

3. Remove the connection (29)  
with a 6 mm Allen wrench.

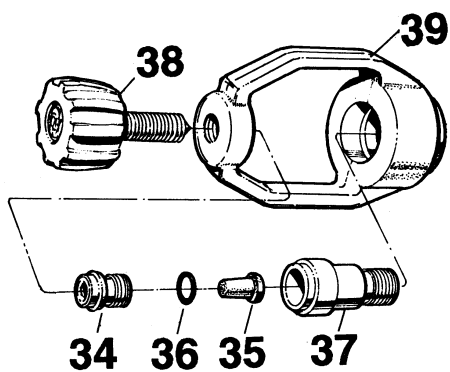

4. New model, remove the locking  
screw (34) with an 6 mm Allen  
wrench. Remove the cup filter  
(35) and the o-ring (36). Remove  
the connection (37) with an 6  
mm Allen wrench.

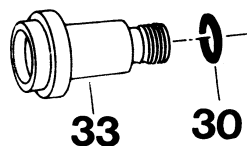

5. Remove the o-ring (30) with an  
o-ring remover. Make sure the  
sealing surface is not damaged.

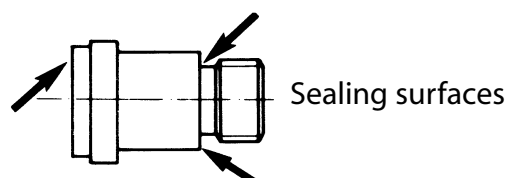

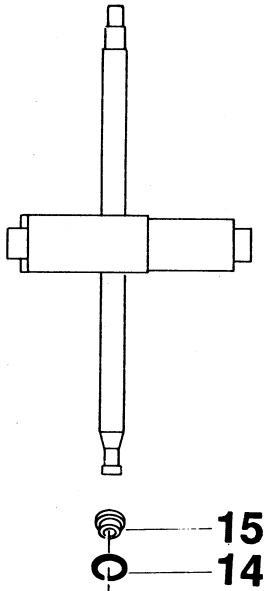

## FIRST STAGE

**2801, 2808, 2962, 3257,  
3580, 3585**

6. Remove the valve seat (15) with a valve seat remover.

7. Remove the o-ring (14) with an oring remover. Make sure the sealing surface is not damaged.

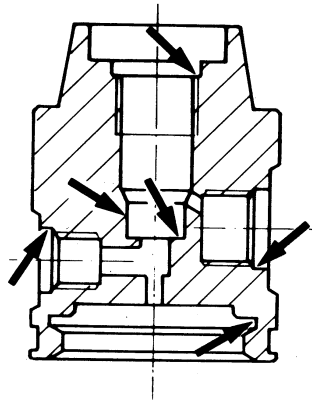
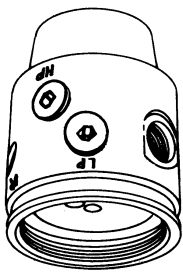

8. Remove the valve housing from the fixture.

9. Remove the blind screw (10 and 13) with a 5 mm and 3= Allen wrench. Remove the o-rings (9 and 12) with an o-ring remover. Make sure the sealing surfaces are not damaged.

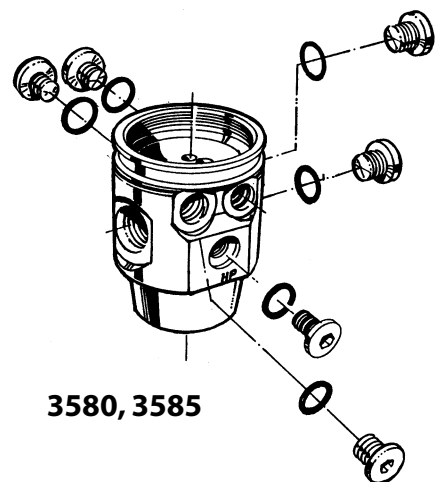
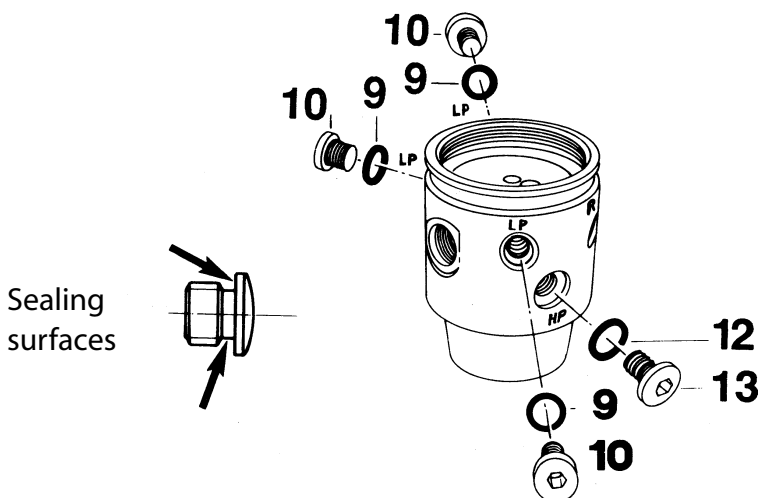

---

When servicing the regulator the following parts should be replaced:  
See chapter Servicekit.

1. All o-rings
  2. Diaphragm
  3. Cup filter
  4. Valve seat
  5. Washer
- 

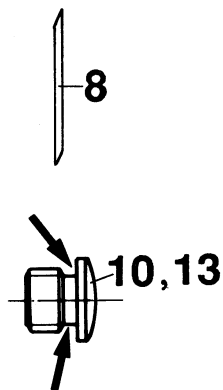

### **CLEANING:**

If corrosion or salt deposits occurs, place all metal parts – concentrated Hempocid\* or 15% Hydrochloric acid for about 10 minutes. Then, rinse the parts thoroughly and blow dry with air. The synthetic parts in the second stage must not be treated with solvent. They shall be cleaned in freshwater only.

### **Checking:**

Check the following parts very carefully. Replace even if only slightly damaged.

1. Valve needle (8). Check to make sure that the needle is straight.
2. The blind screws (10 and 13). Check to make sure the sealing surfaces are undamaged. Also check that the threads are not damaged.



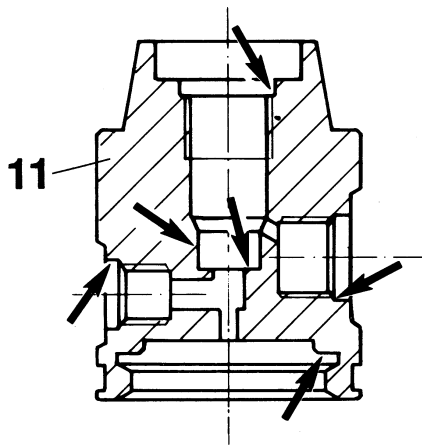

3. The valve housing (11).  
Check to make sure the threads and also the sealing surfaces for the o-rings are undamaged.

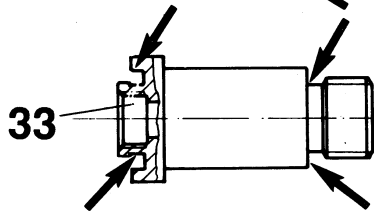
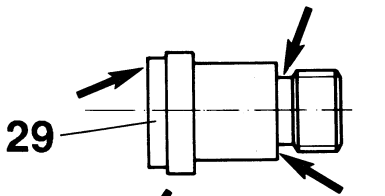

4. The connections (29,31 or 33).  
Check to make sure the sealing surfaces for the o-rings are undamaged.

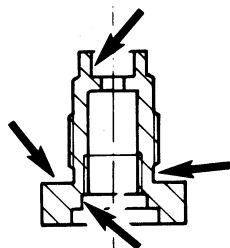
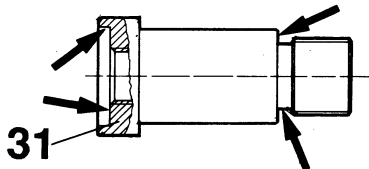

5. Balanced housing (21).  
Check to make sure the threads and also the sealing surfaces for the o-rings are undamaged.

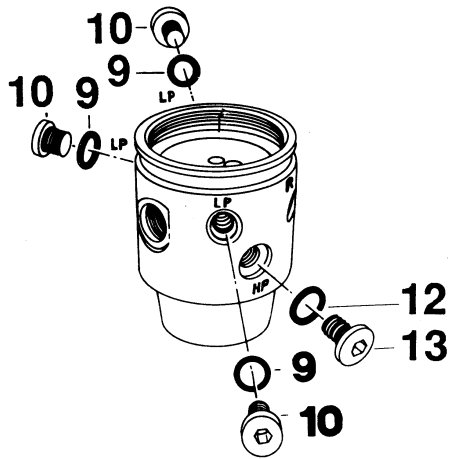

## Assembly

1. Install the o-rings (9) and (12) on the blind screws (10) and (13). Lubricate through the outlets.

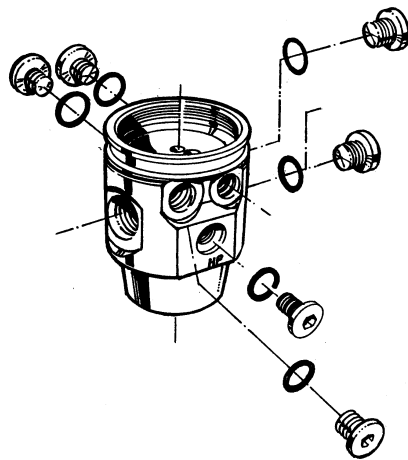

2. Screw in the blind screws in the LP- HP outlets. Use a 5 mm Allen wrench and tighten up by hand.

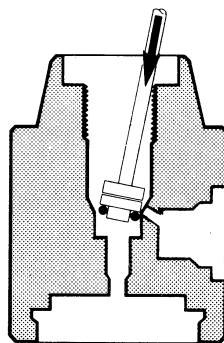

3. Install the o-ring (14) on the valve seat (15) and the install the valve seat with a seat drift. Press the drift diagonally as shown in the diagram and the "rock" it to the vertical while pressing down. The seat and o-ring should pop into place. This procedure avoids damage to the o-ring from the high pressure supply outlet.

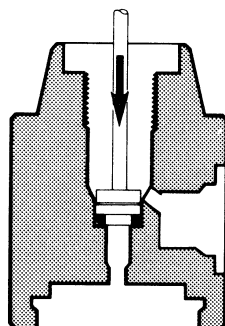

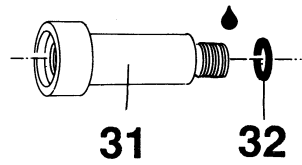

## FIRST STAGE 2962, 3257, 3580, 3585

### Assembly:

1. Install the o-ring (31) on the connection (30). Lubricate the o-ring and the thread.

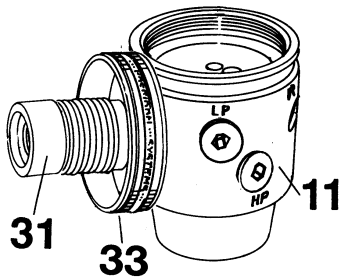

2. Install the wheel (33) on the connection.

3. Screw the wheel connection assembly into the valve housing assembly with a 6 mm Allen wrench.

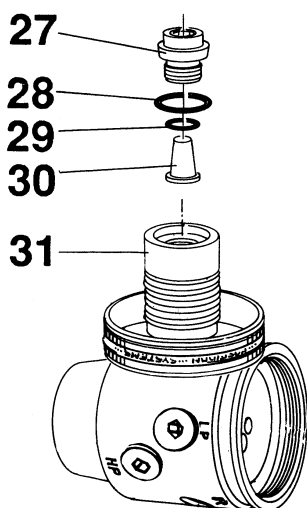

Place the valve housing (11) in a fixture. Tighten with a torque wrench to 28 - 30 Nm (20-22 lbf.ft.).

**IMPORTANT!** Use bits No 3119 (L = 40 mm). Put o-ring (29) on the cup type filter (30). Install these and o-ring (28) and the locking screw (27) in connection (31). Tighten with a Allen wrench 6 mm.

## FIRST STAGE 2801, 3257 10, 3585 10

### Assembly:

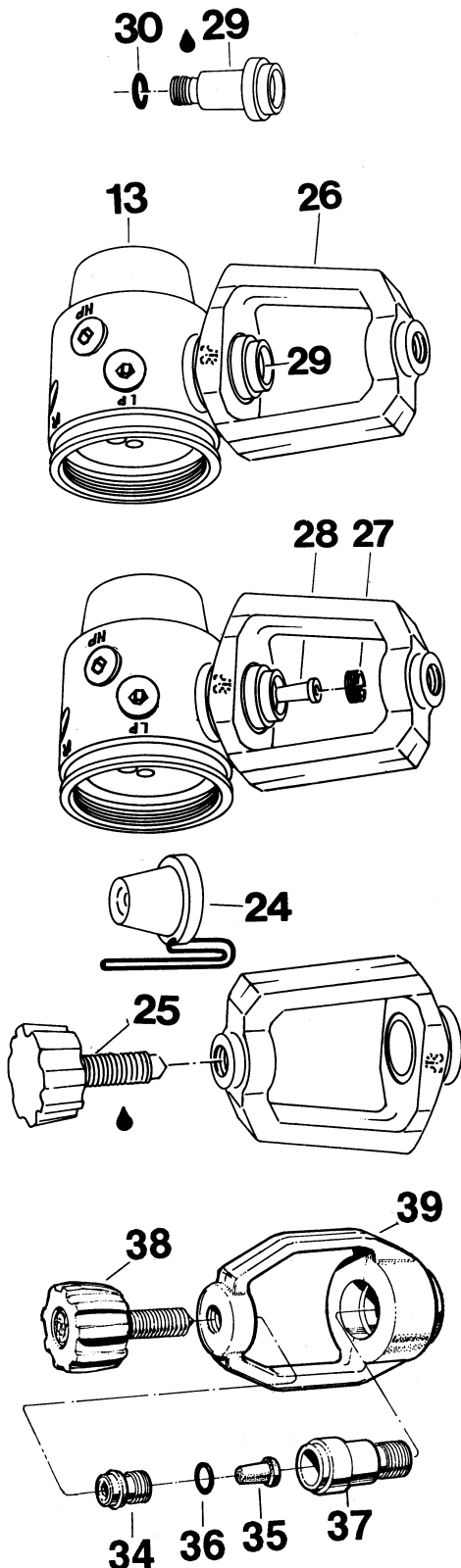

1. Install the o-ring (30) on the connection (29). Lubricate the thread and the o-ring.
2. Place the connection (29) in the Yoke (26) and screw the connection into the valve housing (13) using a 6 mm Allen wrench. Place the valve housing in a fixture. Tighten with a torque wrench to 28 - 30 Nm (20-22 lbf.ft). Use bits no 2883 (length 30 mm)
3. Install the cup filter (28). Screw in the locking screw (27) with a 8.5 mm screw driver. Install the protective cap (24). Grease the thread and screw in the knob.
4. New model. Place the connection (37) in the Yoke (39) and screw the connection into the valve housing, using a 6 mm Allen wrench. Place the valve housing in a fixture. Tighten with a torque wrench to 28 - 30 Nm (20-22 lbf.ft). Use bits no 3119 (length 40 mm)
5. Install the o-ring (36) on the cup type filter (35). Place the filter in the connection (37).
6. Install the protective cap, grease the thread and screw in the knob.

## FIRST STAGE 2808

### Assembly:

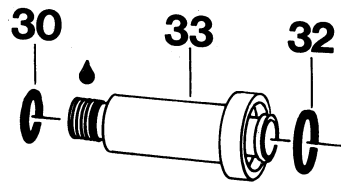

1. Install the o-rings (30, 32) on the connection (33). Grease the o-ring (30) and thread.

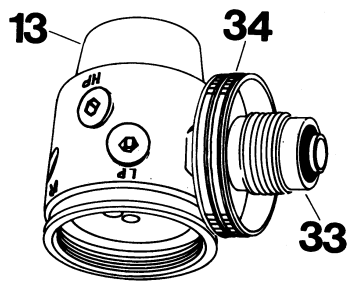

2. Fit the connection (33) to the wheel (34) and screw it into the valve housing (13) with a 6 mm Allen wrench. Place the valve housing in torque wrench to 28 - 30 Nm. (20-22 lbf.ft).

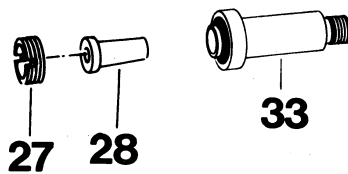

3. Install the cup filter (28) screw in the locking screw (27) with an 8.5 mm screwdriver.

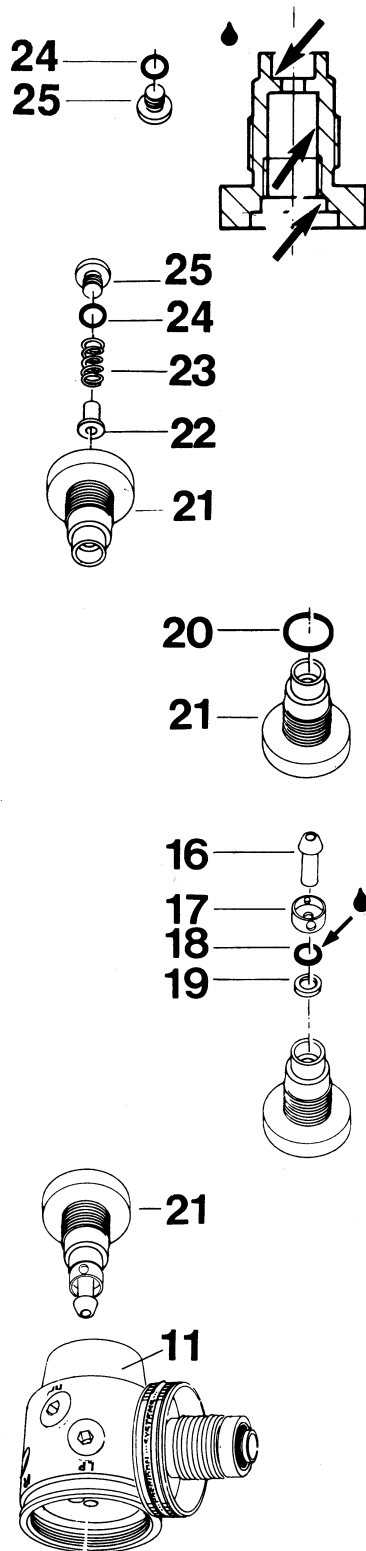

## FIRST STAGE

### BALANCED HOUSING

1. Install the o-ring (24) on the blind screw G 1/8" (25).
2. Grease the inside of balanced housing (21).
3. Install the spring guide (22) and the spring (23). Screw in the blind screw (11) with a 5 mm Allen wrench. The blind screw should be tightened while the balanced housing is held in the valve housing.
4. Install the o-ring (20) at the balanced housing .
5. Install the washer (19) and the o-ring (18). Grease the inside of o-ring and the washer. Install the spacing sleeve (17) and the valve piston (16).
6. Install the balanced housing (21) in the valve housing (11) and tighten the blind screw with a 5 mm Allen wrench.

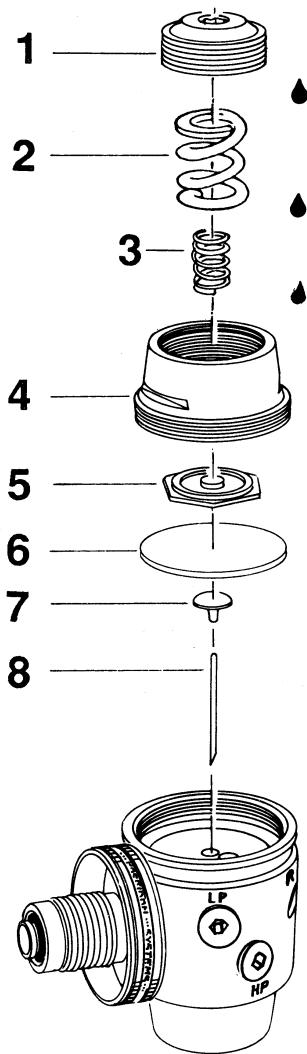

7. Turn the valve housing with the secondary side upwards.

8. Install the valve needle (10). At previous models the needle was beveled in one edge. The bevel should in these cases be pointed downwards.

9. Install the lower diaphragm centre (7) and the diaphragm (6), which must be pushed into the groove in the valve housing. Check to make sure that this is correctly installed by pressing it downwards. It should move approximately 2 mm (1/16").

10. Install the upper diaphragm centre (5).

11. Install the cover (4) and tighten with a torque wrench to 28 - 30 Nm. (20-22 lbf.ft).

12. Install the spring (2) and (3), lubricate both ends of the spring and the thread on pressure adjusting screw, and tighten 5 turns with a 6 mm Allen wrench.

# REPAIR INSTRUCTIONS FIRST STAGE REDUCING VALVE

3790 - First stage G 5/8"

3790-10 - First stage YOKE

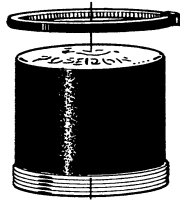

ANTI-FREEZE CAP

## DIFFERENT CONNECTIONS

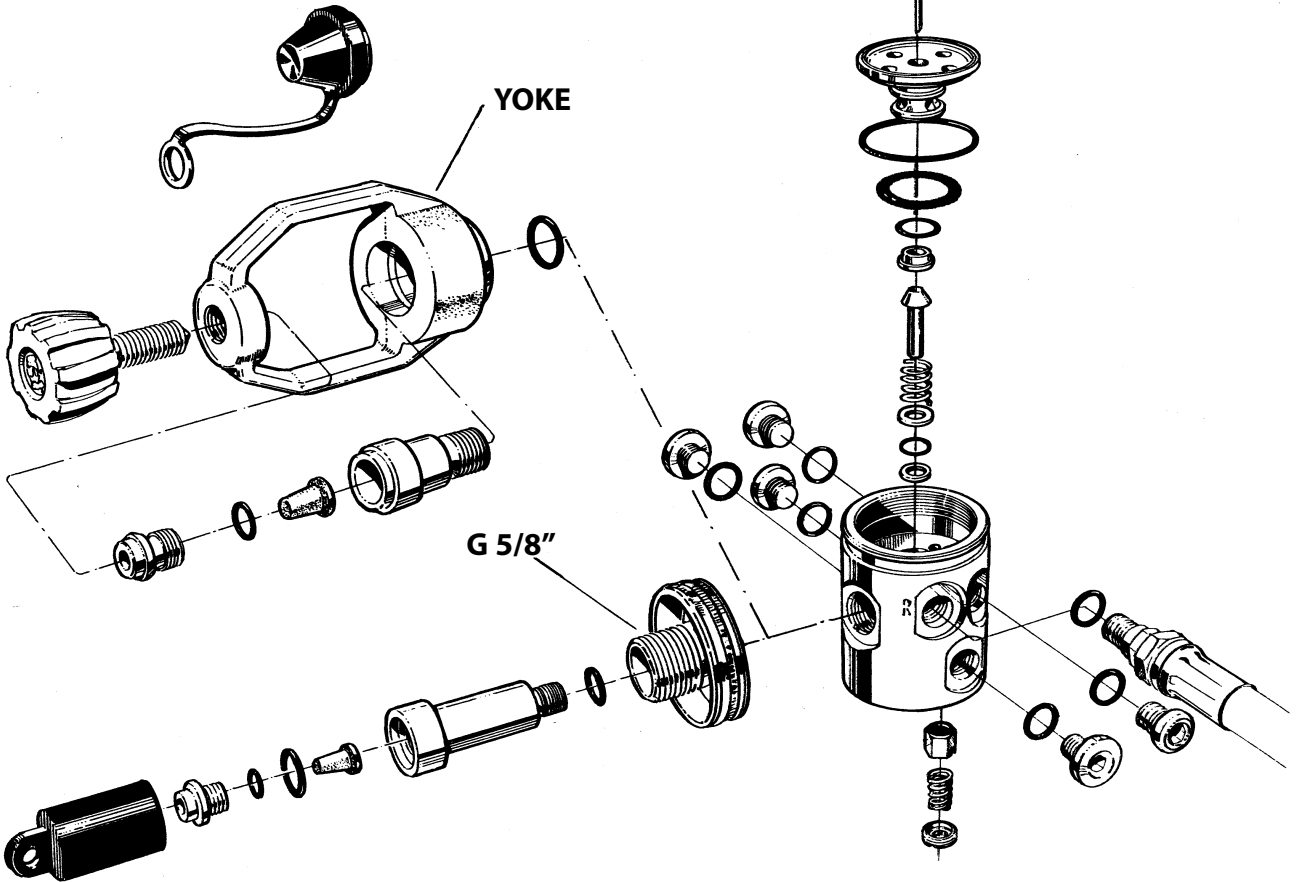

SAFETY VALVE



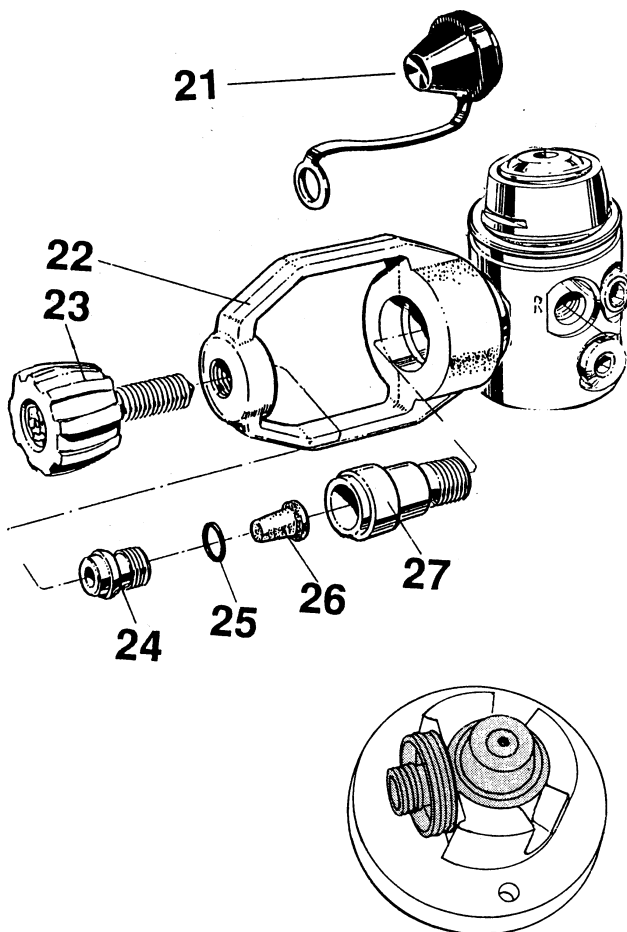
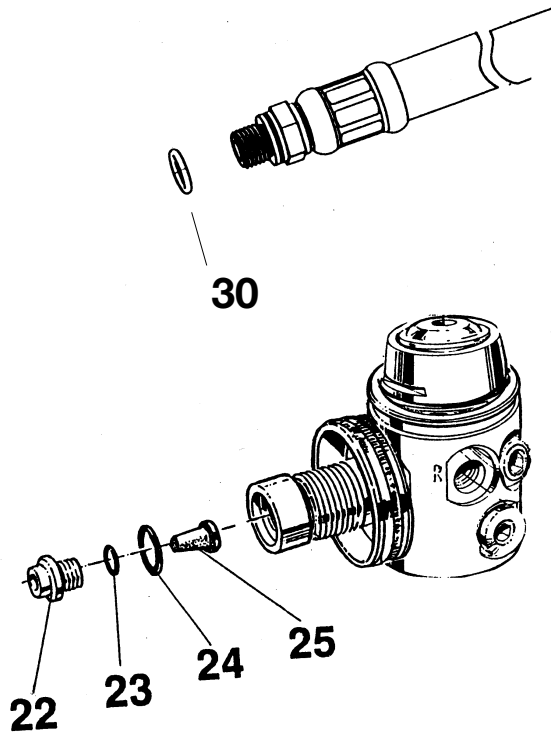

## FIRST STAGE VALVE 3790

### Secondary side:

1. Disconnect the low pressure hose from the first stage valve using a 13 mm open end wrench.
2. Remove the o-ring (30) from the low pressure hose with the o-ring remover.

### First stage valve with G 5/8":

3. Remove the locking screw (22) with a 6 mm Allen wrench. Remove the o-ring (24) and the cup-filter (25) with o-ring (23).

### First stage valve with Yoke:

3. Remove the knob (23) and the protective cap (21). Remove the locking screw (24) with a 6 mm Allen wrench. Remove the cup filter (26) and the o-ring (25).
4. Place the first stage valve with the secondary side facing upwards in the fixture.

## FIRST STAGE VALVE 3790

### Removal:

1. Remove the pressure adjusting screw (1) with a 6 mm Allen wrench and remove the spring (2 and 3).
2. Remove the cover (4) using a 27 mm crowsfoot and the upper diaphragm center (5).

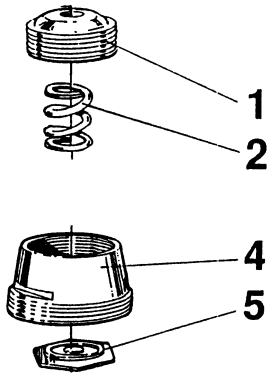

### First stage valve with G 5/8":

3. Remove the connection (26) and the wheel (28) with a 6 mm Allen wrench.
4. Remove the o-ring (27) with an o-ring remover. Make sure the sealing surfaces are not damaged.

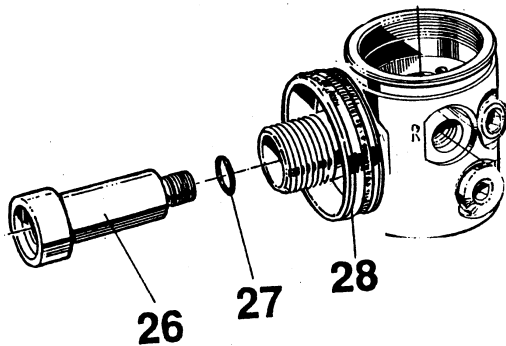

### First stage valve with Yoke:

3. Remove the connection (27) and the yoke (22) with a 6 mm Allen wrench.
4. Remove the o-ring (28) with an o-ring remover. Make sure the sealing surfaces are not damaged.

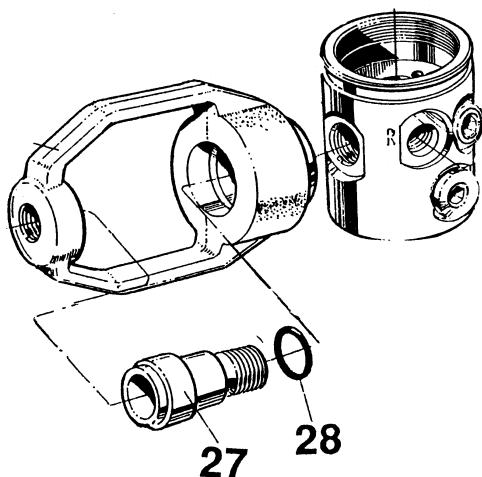

## FIRST STAGE VALVE 3790

### Removal:

1. Remove the valve centre, upper (6) and the diaphragm (7).
2. Remove the diaphragm centre, lower (8) and the valve needle (9).
3. Remove the valve centre, lower (10) and the o-ring (11) with an o-ring remover. Make sure the sealing surfaces are not damaged.
4. Remove the o-ring (12), only 3790, from the valve centre, lower (10) with an o-rings remover. Make sure the surfaces are not damaged.
5. Remove the valve seat (14) and the o-ring (13) with the assembly drift A.
6. Remove the valve piston (15) and the pressure spring (16).
7. Remove the washer, steel (17), the o-ring (18) and the washer, teflon (19) with an o-ring remover. Make sure the surfaces, are not damaged.

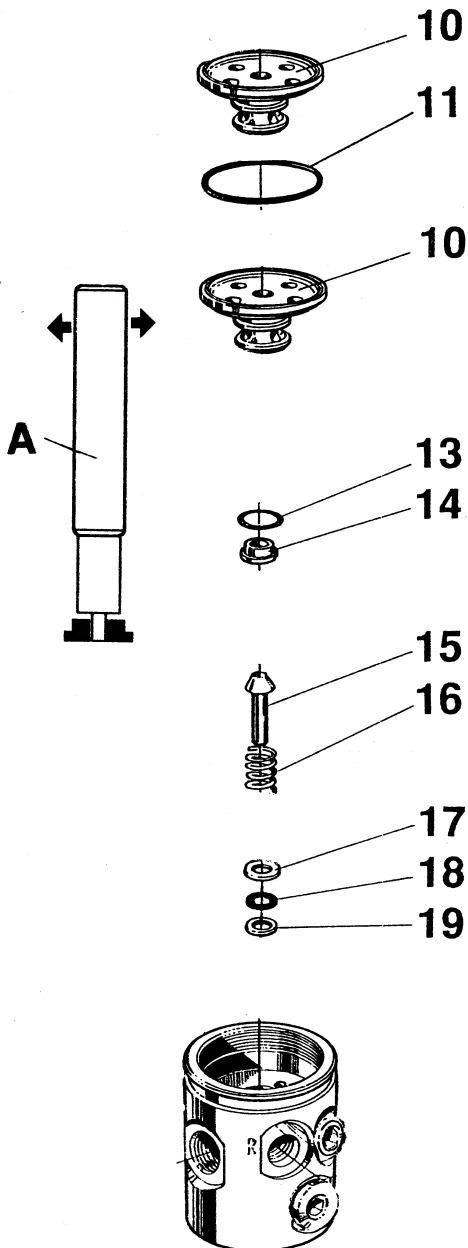

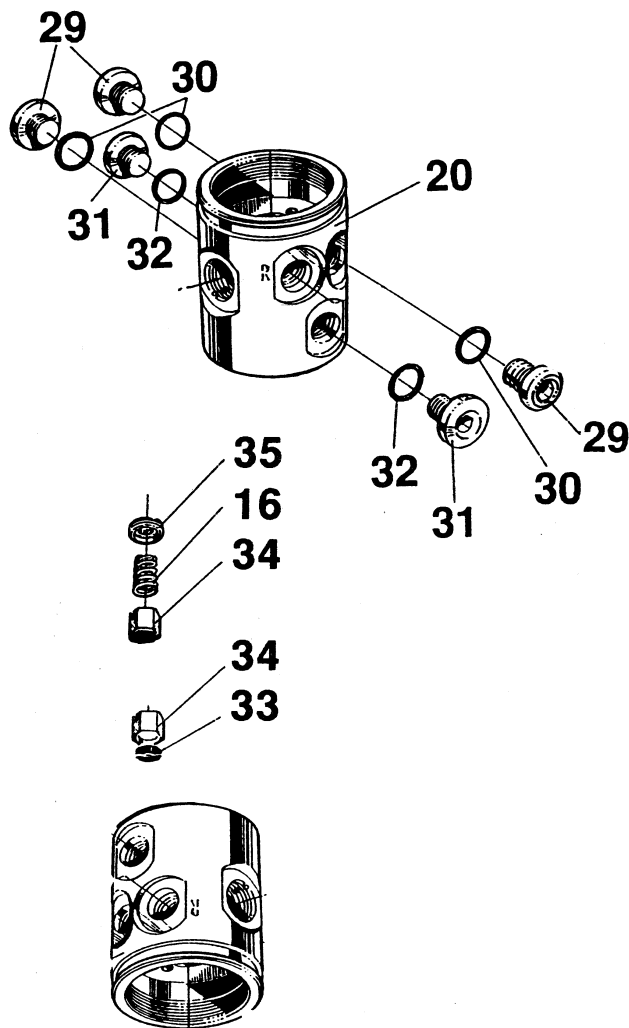

## FIRST STAGE VALVE 3790

### Removal:

1. Remove the blind screw (29 and 31) with a 5 mm Allen wrench. Remove the o-rings (30 and 32) with an o-ring remover. Make sure the sealing surfaces are not damaged.
2. Remove the locking screw (35) with a 4mm Allen wrench. Remove the pressure spring (16) and the valve piston (34).
3. Remove the valve sealing (33) from the valve piston (34) with an o-ring remover.

### Cleaning:

If corrosion or salt deposits occurs, place all metal parts in concentrated Hempodid\* or 15% Hydrochloric acid for about 10 minutes. Then rinse them thoroughly and blow dry with air. The synthetic parts in the second stage must not be treated with solvent. They shall be cleaned in freshwater only. \*Hempodid = Acid Liquid Detergent Containing phosphoric acid (5-10%) and bactericid for desinfectant cleaning.

## FIRST STAGE VALVE, 3790

**When servicing the regulator  
the following parts should be  
replaced:**  
(see chapter Servicekit)

1. All o-rings
2. Diaphragm
3. Cup filter
4. Valve seat
5. Washer
6. Valve sealing

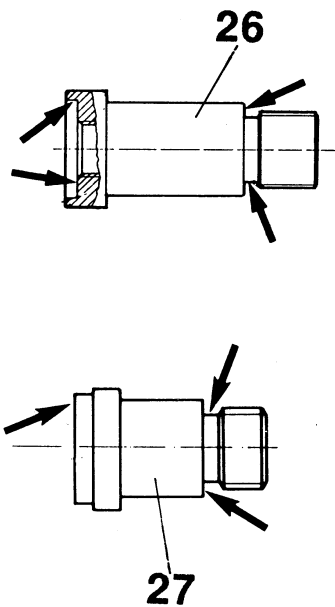
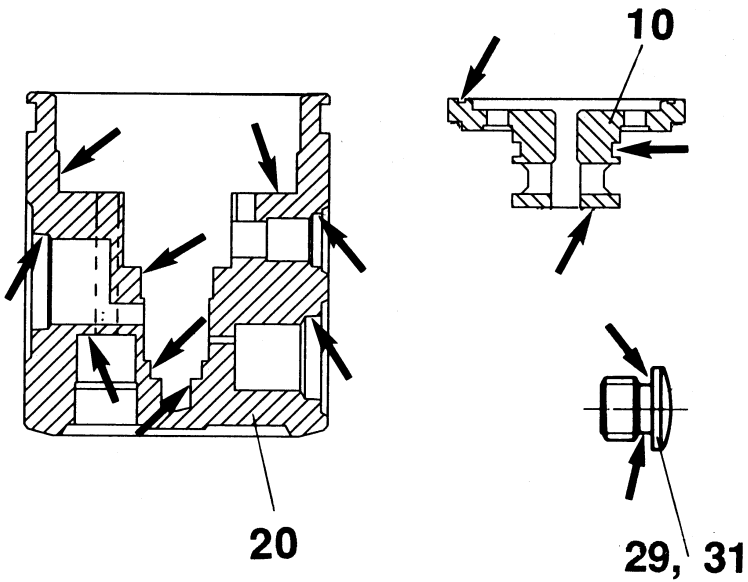

### Checking:

Check the following parts to make sure the sealing surfaces are undamaged. Also check that the threads are not damaged.

1. The blind screws (29 and 31)
2. The valve housing (20)
3. Valve centre (10)
4. The connections (26 or 27)

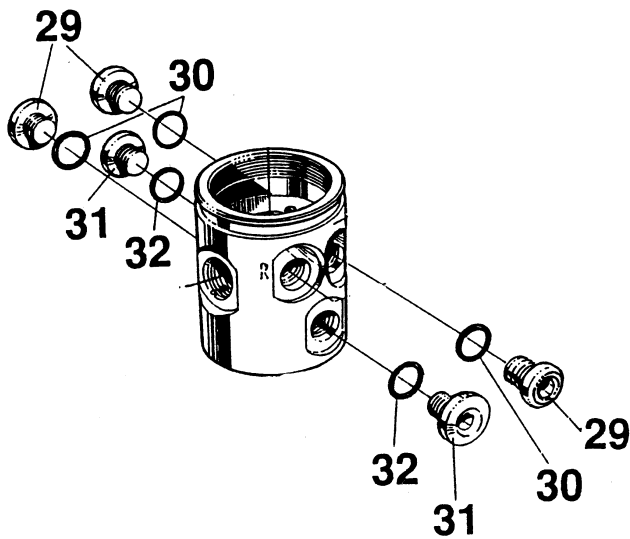

## FIRST STAGE VALVE 3790

### Assembly:

1. Install the o-rings(30 and 32) on the blind screws (29 and 31). Lubricate the outlets.
2. Screw the blind screws in the LP-HP outlets. Use a 5 mm hexagon spanner and tighten up by hand.

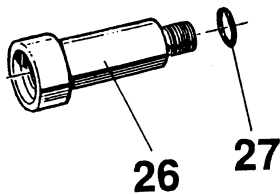

### First stage valve with G 5/8":

1. Install the o-ring (27) on the connection (26). Lubricate the o-ring and the thread.
2. Install the wheel (28) on the connection.
3. Screw the wheel connection assembly into the valve housing assembly with a 6 mm Allen wrench.

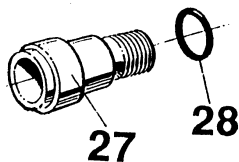
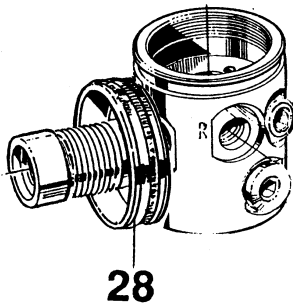

### First stage valve with Yoke:

1. Install the o-ring (28) on the connection (27). Lubricate the o-ring and the thread.
2. Install the yoke (22) on the connection.
3. Screw the wheel connection assembly into the valve housing assembly with a 6 mm Allen wrench.

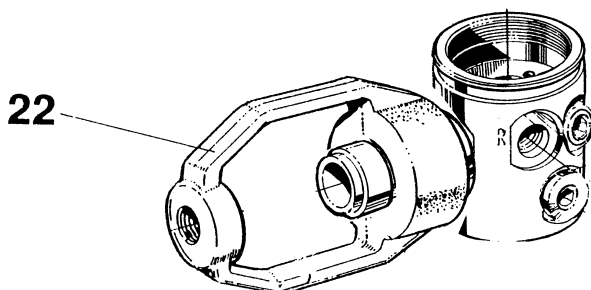

## FIRST STAGE VALVE 3790

### Assembly:

1. Lubricate the valve housing (20).

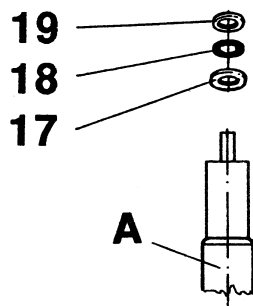
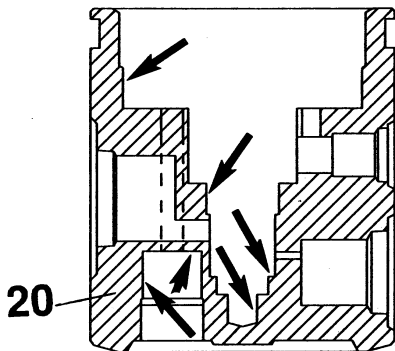

2. Place on the assembly drift A:

-washer, steel (17)

-O-ring (18)

-washer, teflon (19)

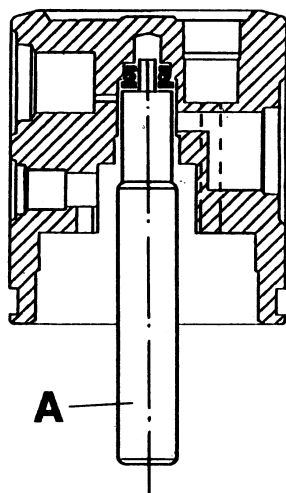

3. Install the valve housing.

Lubricate the washers

and the o-ring.

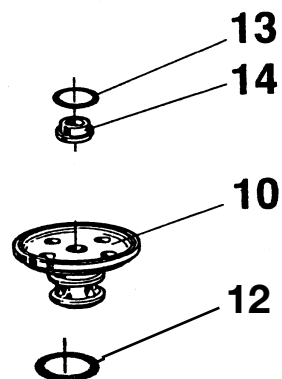

4. Install the o-ring (13) on the  
valve seat (14).

5. Install the o-ring (12), on the  
valve centre, lower (10).

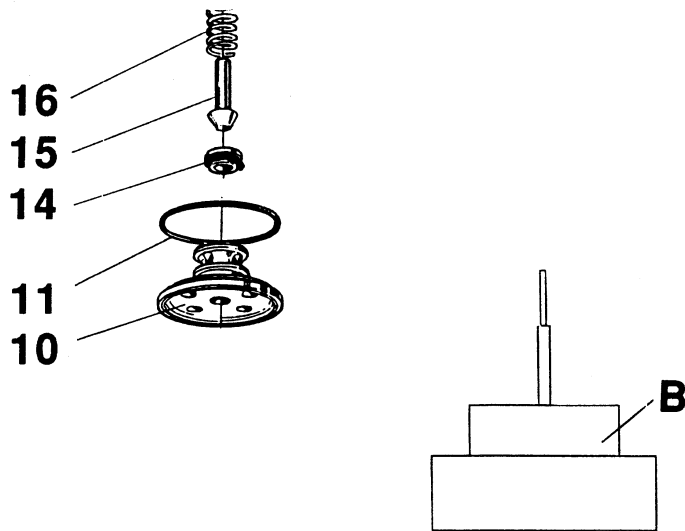

## FIRST STAGE VALVE 3790

### Assembly:

1. Place on the assembly fixture B:
  - valve centre, lower (10)
  - o-ring (11), lubricate
  - valve seat (14) with o-ring downwards
  - valve piston (15), lubricate, and pressure spring (16) on valve piston.

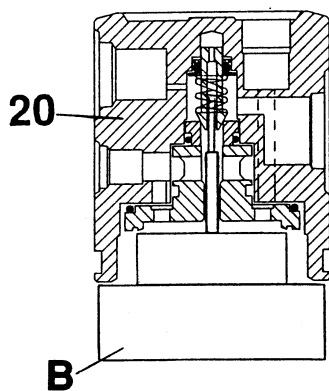

2. Install the valve housing (20).

3. Turn the valve housing (20) with the secondary side upwards.

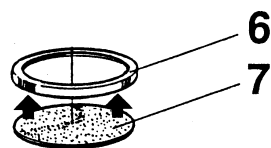

4. Install the valve needle (9).

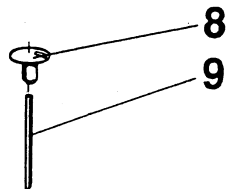

5. Install the lower diaphragm centre (8).

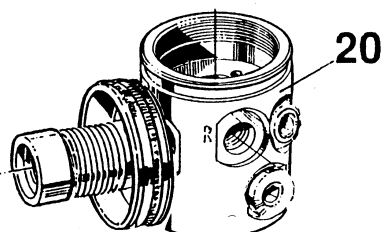

6. Install the diaphragm (7) in the valve centre, upper, convex part up (6). Install the valve housing (20).



## FIRST STAGE VALVE 3790

### Assembly:

1. Install the diaphragm centre, upper (5) in the valve housing (20).
2. Grease the thread on the cover (4) and tighten up by hand.
3. Check to make sure that the parts are correctly installed by pressing at the valve centre. It should move approximately 2 mm (1/16").
4. Lubricate both ends of the spring (2 and 3) and install. Lubricate the thread on pressure adjusting screw (1), and tighten 7 turns with a 6 mm Allen wrench.
5. Install the valve sealing (33) on the valve piston (34).
6. Install the valve piston (34) and the pressure spring (16). Install the locking screw (35) with a 4 mm Allen wrench. Tighten up by hand.

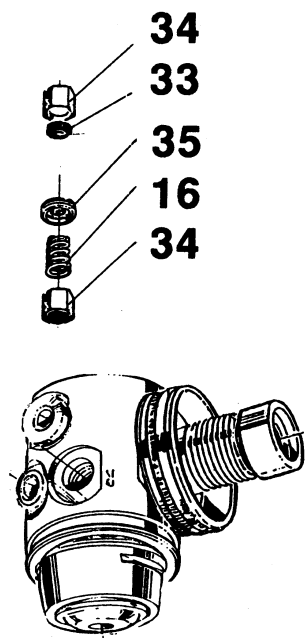
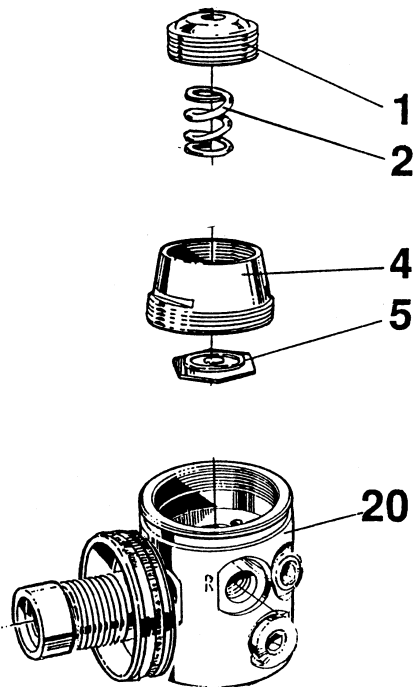

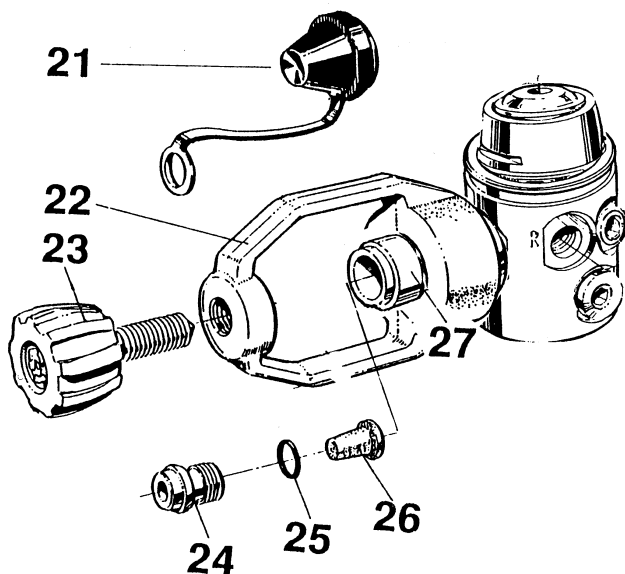
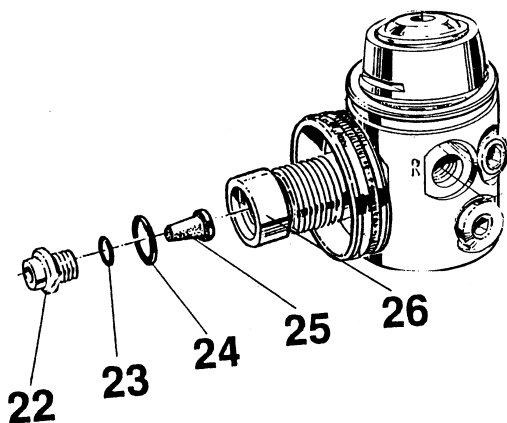
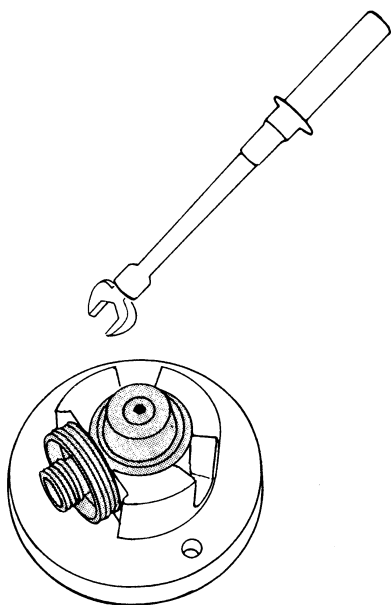

## FIRST STAGE VALVE 3790

### Assembly:

1. Place the valve housing (20) in a fixture.
2. Tighten the cover for valve housing with a torque wrench (30 Nm) and an open ended insert tool 27 mm.
3. Tighten the connection with a torque wrench (30 Nm) and holder insert tool/ bits.  
**IMPORTANT!** Use bits nr 3119 (L = 40 mm).

### First stage valve with G5/8":

4. Put o-ring (23) on the cup type filter (25). Install them and the o-ring (24) and the locking screw (22) in the connection (26). Tighten with a Allen wrench 6 mm.

### First stage valve with Yoke:

4. Put o-ring (25) on the cup type filter (26). Install them and the locking screw (24) in the connection (27). Tighten with a Allen Wrench 6 mm. Put the protective cap (21) on the knob (23). Lubricate and screw in the knob.
5. Install o-ring (30) on the low pressure hose. Lubricate the o-ring and the thread. Tighten the hose with a 13 mm open wrench.

# TESTING AND ADJUSTMENT OF REGULATOR

## JETSTREAM Art. No. 2960, 3960

### First stage valve:

1. Connect the regulator to the test equipment.
2. Connect the test manometer hose to one of the low pressure outlets.
3. Open the LP valve (=20 bar).
4. Set the secondary pressure at 10 bar, and intermittently purge the second stage by means of the purge button. NOTE that the second stage valve must be fully tight during this test. When the pressure gauge needle stops at the preset pressure, a maximum rise in pressure of 1 bar is allowed before the needle finally stops. If the needle continues to move to a higher pressure reading there is a fault in the seal between the valve seat and piston or the O-ring.
5. Close the LP valve, and open the HP valve (=200/300 bar). Purge intermittently with the purge button, check the tightness, and adjust the pressure to 8.5-9 bar.

### Second stage valve: Tightness testing of the low pressure valve with servo valve.

1. Close the HP valve and purge fully by means of the purge button.
2. Remove the low pressure valve from the second stage housing.
3. Place the low pressure valve in the test fixture and screw on the hose.
4. Open the LP valve, push the servo valve's needle carefully, and purge a few times. Immerse the valve below the surface of the water in a special

water tank and check to make sure that the valve is absolutely tight.

5. Move the low pressure valve to the second stage valve and fit the low pressure valve's outlet to the guide fitting in the second stage housing. Make sure that the valve is inserted straight to prevent the servo valve from becoming damaged.
6. Lubricate the external thread on the second stage housing and the end of the hose nipple. Screw on the low pressure hose.

### Adjustment of the inhalation resistance:

1. Open the HP valve.
2. Connect the oval connecting pipe on the inhalation resistance gauge to the mouth-piece on the regulator.
3. Test-breathe very carefully. Check the reading of the gauge needle, which should rise to 35-40 mm/vp and then move back. The turning point reading equals the inhalation resistance. If the reading is too low, screw the valve tube away from the diaphragm as shown in the illustration. If the reading is too high, screw the valve tube towards the diaphragm.

### Checking the purge button:

1. Press the purge button. The second stage valve should now provide a generous supply of air.
2. Cover the mouth-piece and press the purge button. The second stage valve should then supply a reduced flow air.

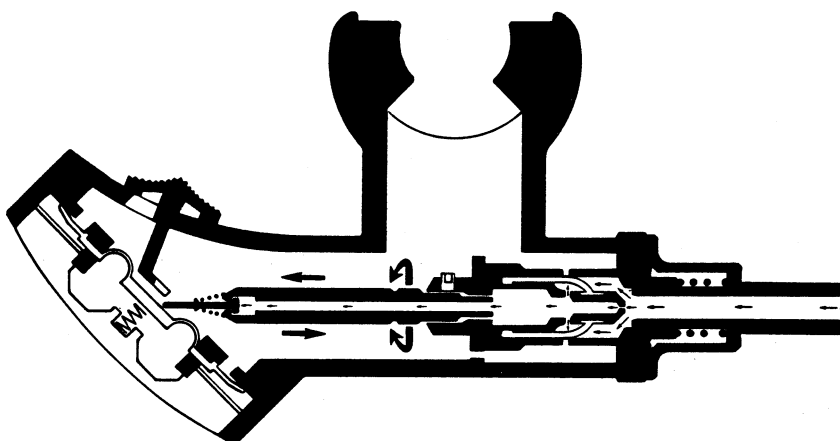

# TESTING AND ADJUSTMENT OF THE REGULATOR

## OCEANAIR Art. No. 2940

### First stage valve:

1. Connect the regulator to the test equipment.
2. Connect the test manometer hose to one of the low pressure outlets.
3. Open the LP valve (=20 bar).
4. Set the secondary pressure at 11.5 bar, and intermittently purge the second stage by means of the purge button. NOTE that the second stage valve must be fully tight during this test. When the pressure gauge needle stops at the preset pressure, a maximum rise in pressure of 1 bar is allowed before the needle finally stops. If the needle continues to move to a higher pressure reading there is a fault in the seal between the valve seat and piston or the O-ring.
5. Close the LP valve, and open the HP valve (=200/300 bar). Purge intermittently with the purge button, check the tightness, and adjust the pressure to 8.5-9 bar.

### Second stage valve: Tightness testing of the low pressure valve with servo valve.

1. Close the HP valve and purge fully by means of the purge button.
2. Remove the low pressure valve from the second stage housing.
3. Place the low pressure valve in the test fixture and screw on the hose.
4. Open the LP valve, push the servo valve's needle carefully, and purge a few times. Immerse the valve below the surface of the water in a special

water tank and check to make sure that the valve is absolutely tight.

5. Move the low pressure valve to the second stage valve and fit the low pressure valve's outlet to the guide fitting in the second stage housing. Make sure that the valve is inserted straight to prevent the servo valve from becoming damaged.
6. Lubricate the external thread on the second stage housing and the end of the hose nipple. Screw on the low pressure hose.

### Adjustment of the inhalation resistance:

1. Open the HP valve.
2. Connect the oval connecting pipe on the inhalation resistance gauge to the mouth-piece on the regulator.
3. Test-breathe very carefully. Check the reading of the gauge needle, which should rise to 35-40 mm/vp and then move back. The turning point reading equals the inhalation resistance. If the reading is too low, screw the valve tube away from the diaphragm as shown in the illustration. If the reading is too high, screw the valve tube towards the diaphragm.

### Checking the purge button function:

1. Press the purge button. The second stage valve should now provide a generous supply of air.
2. Cover the mouth-piece and press the purge button. The second stage valve should then supply a reduced flow of air.

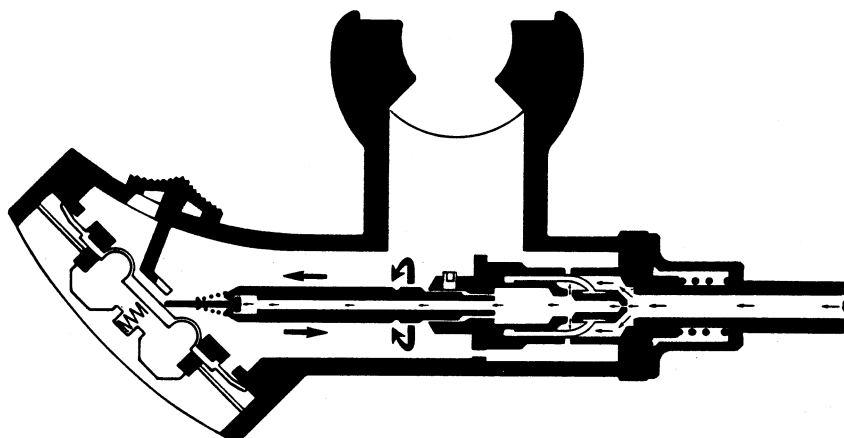

## **Poseidon Cyklon 300**

### **BREATHING REGULATOR**

**Art. No 2980**

Primary pressure .....	Max. 4350 PSI / 300 bar
Secondary pressure .....	Max. 181 PSI / 12.5 bar
Air flow .....	Approximately 800 l/min
Inhalation resistance at 115 l/min.....	Max. 40 mm of water
Exhalation resistance .....	Max. 20 mm of water

*The above data apply when measuring at atmospheric pressure*

### **FIRST STAGE VALVE**

**Art. No 3070**

Description.....	Diaphragm-operated, compensated
Connection threads for primary pressure .....	G 5/8" -max. 4350 PSI / 300 bar
Outlet connections: Four outlets marked LP for second stage, drysuits, buoyancy compensators, hookah supply, safety second stage, etc .....	UNF 3/8" -secondary pressure
One outlet marked HP.....	UNF 7/16"-primary pressure

### **SECOND STAGE VALVE**

Type designation .....	<b>Art. No 1133, 3536</b>
Description.....	Downstream type, diaphragm actuated. Integral safety valve opens at approximately 203 PSI / 14 bar. Purge button for clearing.

### **REGULATOR HOSE**

**Art. No 2946**

Length.....	28 inch / 70 cm
-------------	-----------------

### **TIGHTENING TORQUE**

Primary connection .....	20-22 lbf.ft / 28-30 Nm
Valve cover .....	20-22 lbf.ft / 28-30 Nm
Connections marked LP-HP.....	6 lbf.ft / 8 Nm

### **ANTI-FREEZE PROTECTION**

Type designation .....	<b>Art. No 1286</b>
Type .....	Rubber cap

## **Poseidon Cyklon 5000**

### **BREATHING REGULATOR**

**Art. No 2950**

Primary pressure .....	Max. 4350 PSI / 300 bar
Secondary pressure .....	Max. 174 PSI / 12 bar
Air flow .....	Approx. 1050 l/min
Inhalation resistance at 115 l/min.....	Max. 40 mm of water
Exhalation resistance .....	Max. 20 mm of water

*The above data apply when measuring at atmospheric pressure*

### **FIRST STAGE VALVE**

**Art. No 3257, 3585**

Description.....	Diaphragm-actuated, balanced.
Connecting threads for primary pressure.....	G 5/8 -max 4350 PSI /300 bar accord. SS 2600/K and DIN 477/5 or yoke connection accord. SS 2603 and ANSI/CGA VI: 1987

Outlet connections:

One outlet marked R for second stage (max airflow).....	UNF 3/8" - secondary pressure
Three outlets marked LP for drysuits, buoyancy compensators, hookah supply, safety second stage etc.....	UNF 3/8" -secondary pressure
One outlet marked S has restricted airflow and therefore is intended only for dry-suit or stabjacket ..	Intended for first stage No. 3585 UNF 3/8" -secondary pressure
One outlet marked HP for pressure gauge.....	UNF 7/16" -primary pressure

### **SECOND STAGE VALVE**

**Art. No 1133**

Description.....	Downstream-type, diaphragm actuated. Integral safety opens with approximately 203 PSI/14 bar. Purge button for clearing.
------------------	--

### **REGULATOR HOSE**

Length.....	28 inch / 70 cm
-------------	-----------------

### **TIGHTENING TORQUE**

Primary connection .....	20 - 22 lbf.ft / 28-30 Nm
Valve cover .....	20 - 22 lbf.ft / 28-30 Nm
Connections marked R-LP-HP .....	6 lbf.ft / 10 Nm

### **ANTI-FREEZE PROTECTION**

Type designation .....	Art. No 1286
Type .....	Rubber cap

## **Poseidon Cyklon 5000**

### **BREATHING REGULATOR**

**Art. No 3950**

Primary pressure .....	Max. 4350 PSI / 300 bar
Secondary pressure .....	Max. 174 PSI / 12 bar
Air flow .....	Approx. 1050 l/min
Inhalation resistance at 115 l/min.....	Max. 40 mm of water
Exhalation resistance .....	Max. 20 mm of water

*The above data apply when measuring at atmospheric pressure*

### **FIRST STAGE VALVE**

**Art. No 3720, 3720 10**

Description.....	Diaphragm-actuated balanced with shear venturi boost. Release pressure approx. 217-247 PSI / 1,5-1,7 MPa / 15-17 bar
Connecting threads for primary pressure.....	G 5/8"-max 4350 PSI / 30 MPa / 300 bar accord. SS 2600/K and DIN 477/5 or yoke connection accord. SS 2603 and ANSI/CGA V1: 1987

Outlet connections:

One outlet marked R for second stage (max. airflow)	UNF 3/8" -secondary pressure
Three outlets marked LP for Cyklon octopus, drysuits, stadjacket.....	UNF 3/8" -secondary pressure
Two outlet marked HP for pressure gauge.....	UNF 7/16" -primary pressure

### **SECOND STAGE VALVE**

**Art. No 1133, 3536**

Description.....	Downstream-type, diaphragm actuated. Integral safety opens with approximately 203 PSI/14 bar. Purge button for clearing.
------------------	--

### **REGULATOR HOSE**

**Art. No 2946**

Length.....	28 inch / 70 cm
-------------	-----------------

### **TIGHTENING TORQUE**

Primary connection, valve cover .....	22 lbf. ft / 30 Nm / 3,0 kpm
Connections marked R-LP-HP.....	6 lbf.ft / 8 Nm, / 0,8 kpm

### **ANTI-FREEZE PROTECTION**

Type designation .....	Art. No 1286
Type .....	Rubber cap

# REPAIR INSTRUCTIONS SECOND STAGE DEMAND VALVE

EXPLODED VIEW  
SECOND STAGE 1133

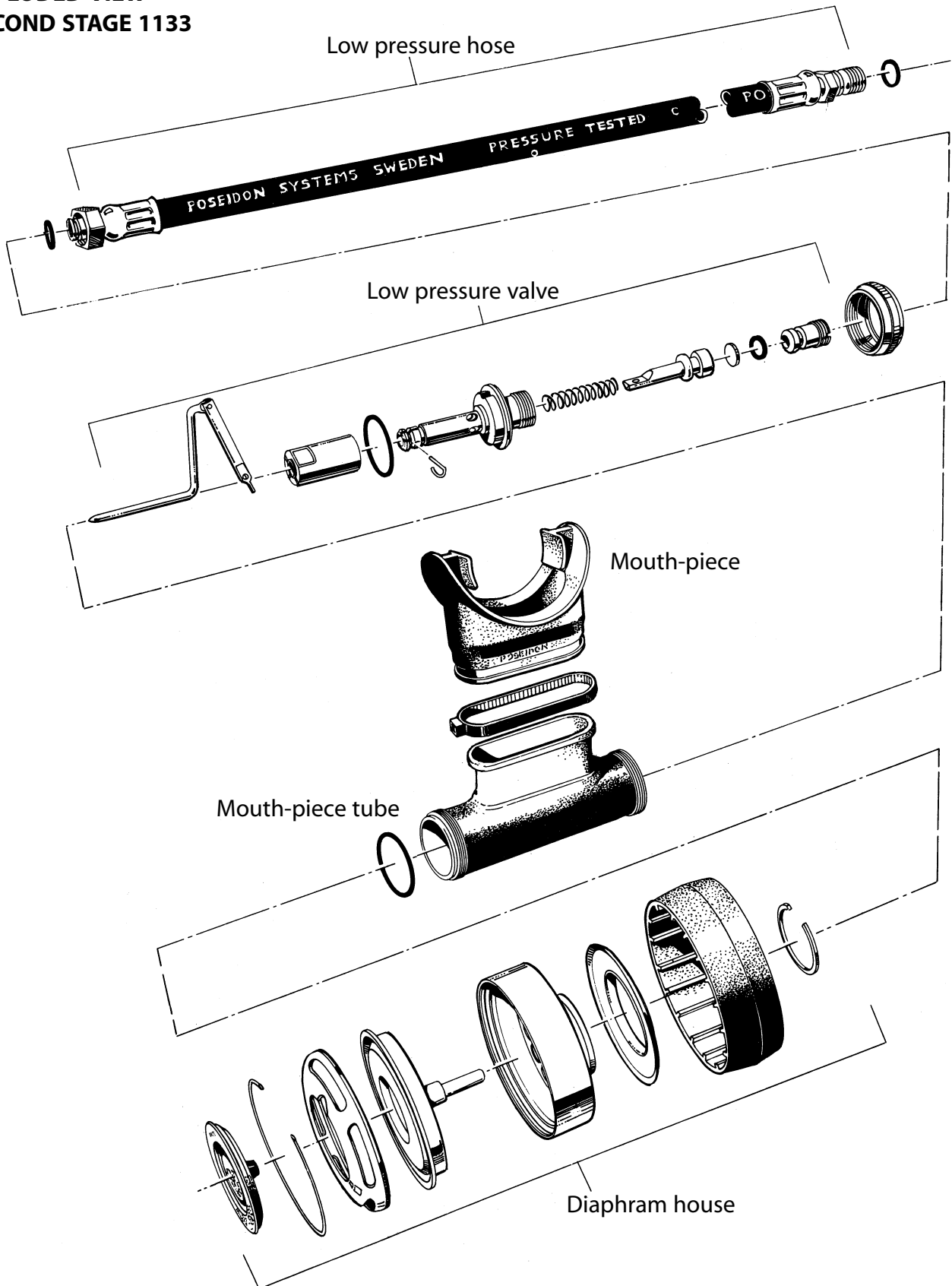



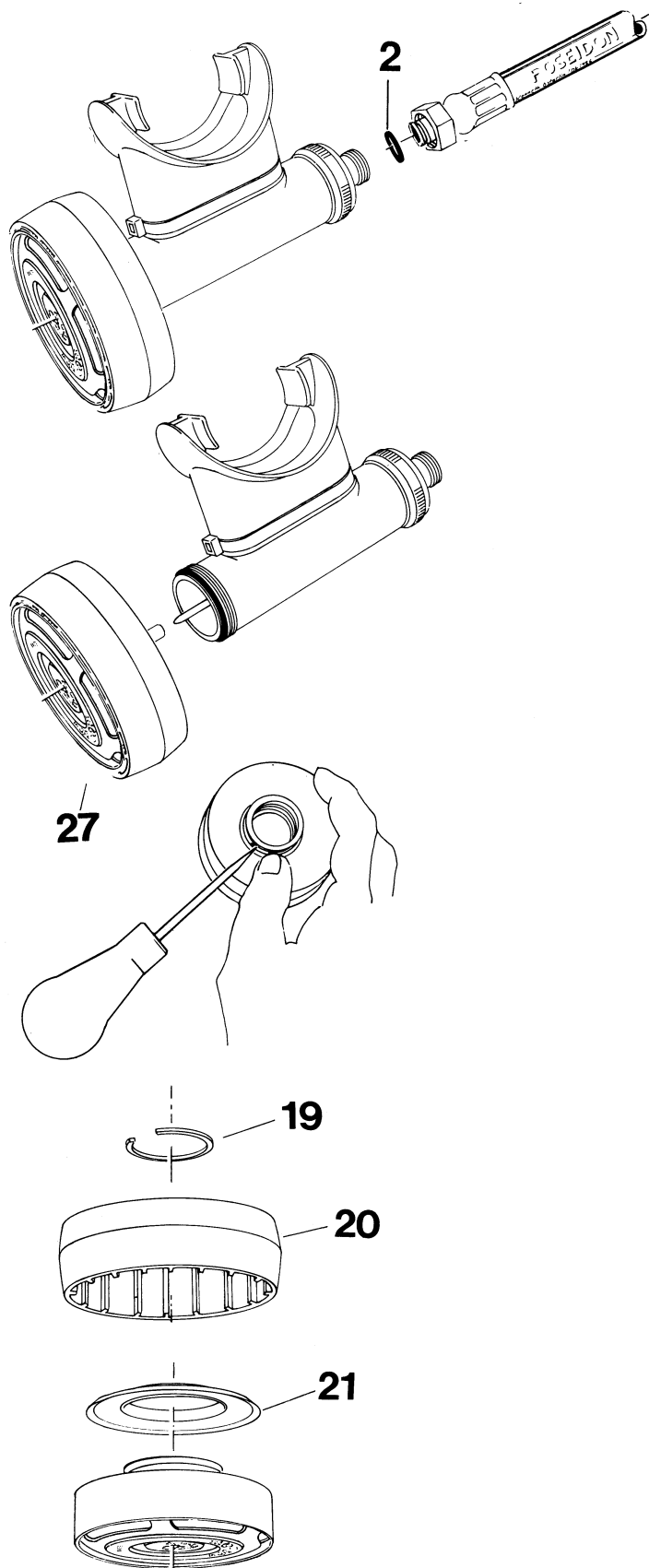

## **SECOND STAGE 1133, 3224, 3354, 3536**

### **Removal:**

1. Disconnect the low pressure hose from the second stage with a 17 mm. open wrench. Remove the oring (2) with an o-rings remover.
2. Remove the diaphragm housing (27) from the mouth piece tube.
3. To release the exhalation cover, remove the locking ring with a small screwdriver.
4. Remove the exhalation diaphragm (21).

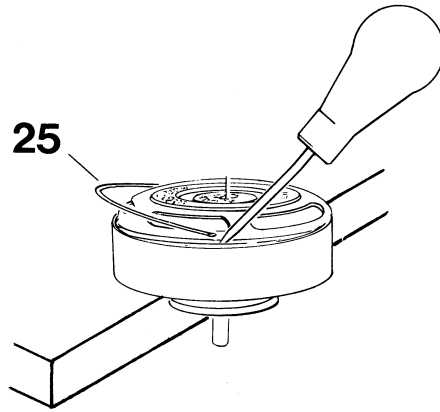

1. Remove the locking ring (25) with an awl. Support the diaphragm house, see diagram. Make sure that the sealing surface for the exhalation diaphragm is not damaged.

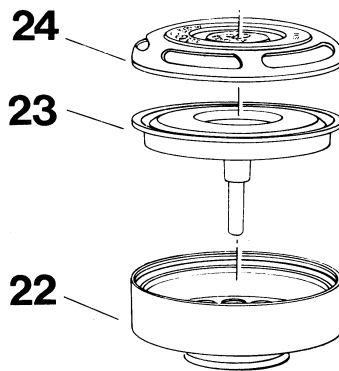

2. Remove the cover (24) and the inhalation diaphragm (23).

**Removal:** Push out the purge button

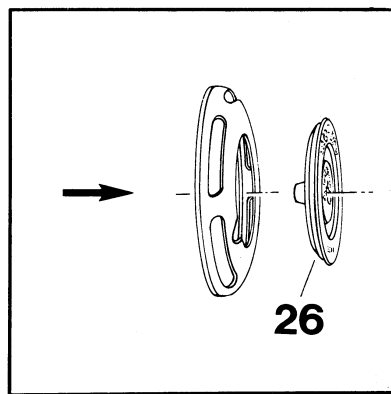

**IMPORTANT!** The purge button (26) should not be removed if it is undamaged

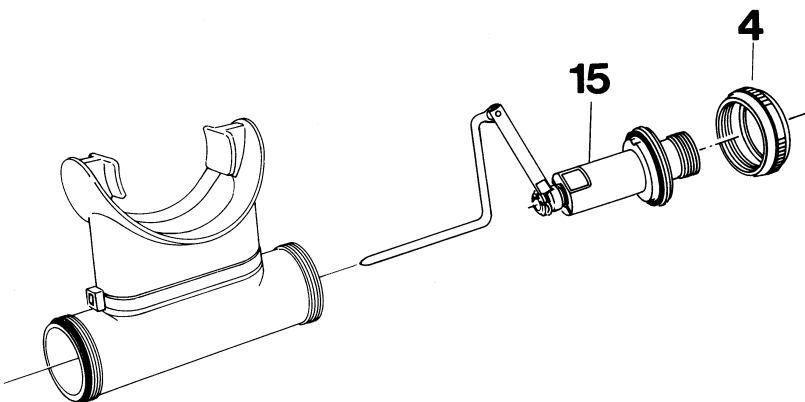

3. Remove the connecting ring (4) and the low pressure valve (15).

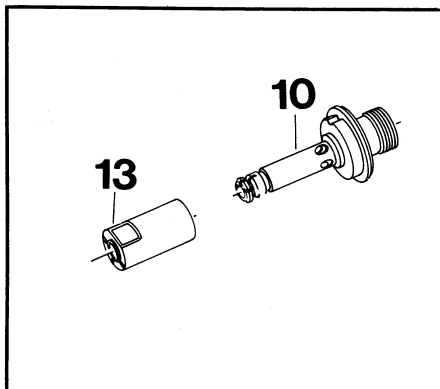
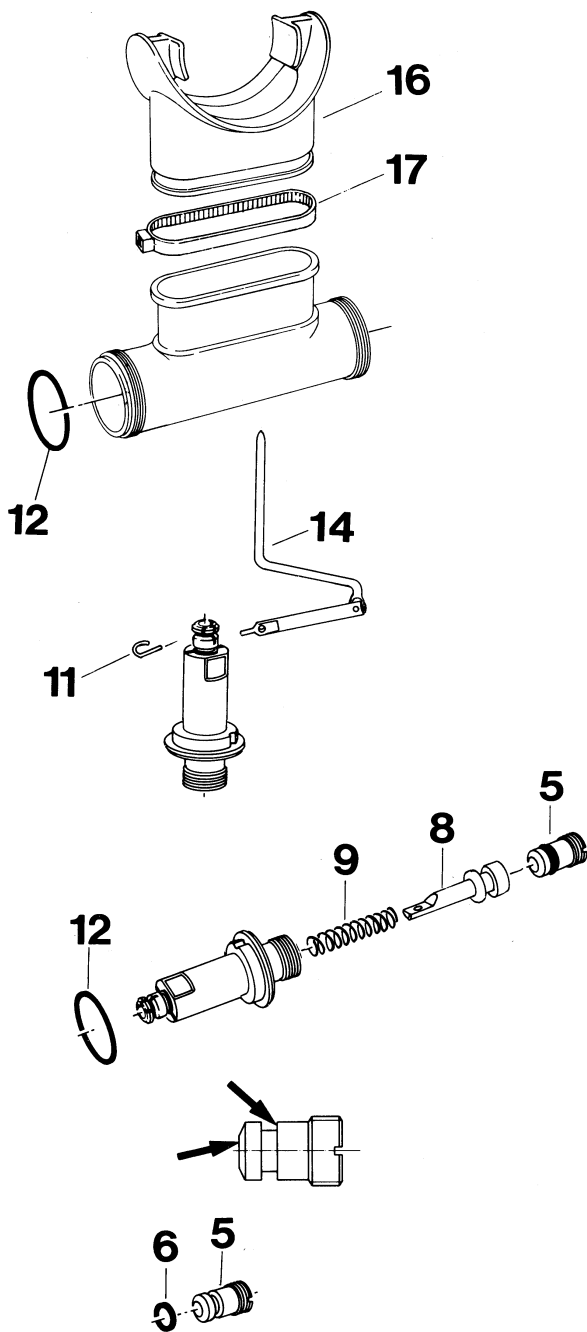

1. Cut off the locking strap (17) with cutting pliers.
  2. Remove the mouth-piece (16) and the o-ring (12).
  1. Remove the lever pin (11).
  2. Remove the operating device (14).
  3. Remove the o-ring (12).
  4. Unscrew the valve seat (5) with an 8.5 mm screwdriver. **NOTE!** the valve seat has a very fragile tightening edge; put the seat with the edge upwards.
  5. Remove the valve piston (8) and the spring (9). In order to protect the piston bond, the old rubber plate should be kept until the new shall be fixed.
  6. Remove the o-ring (6) with an oring remover. Make sure the sealing surfaces are not damaged.
- IMPORTANT!** The ejector sleeve should not be removed if it is functional and undamaged. Check to see that the sleeve can be rotated to any position, but that it does not rotate freely.

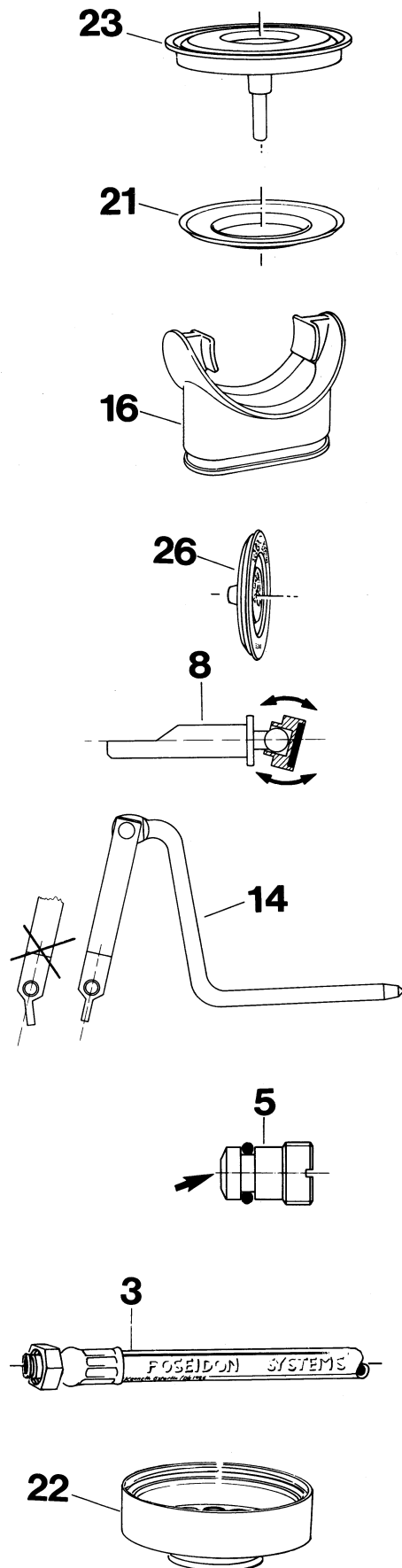

When servicing the regulator the following parts should be replaced:  
See chapter Servicekit.

1. All o-rings, including the one in the low-pressure hose.
2. Rubber plate (7).

**CLEANING:**

If corrosion or salt deposits occurs, place all metal parts – concentrated Hempodid\* or 15% Hydrochloric acid for about 10 minutes. Then, rinse the parts thoroughly and blow dry with air. The synthetic parts in the second stage must not be treated with solvent. They shall be cleaned in freshwater only.

*\*Hempocid = Acid Liquid Detergent Containing phosphoric acid (5 - 10%) and bactericid for disinfectant cleaning.*

**BEFORE INSTALLING CHECK THE FOLLOWING:**

1. Diaphragms (21) (23). Check the sealing surface of the diaphragm to see if it is even and uncracked.
2. The mouth-piece (16).  
Make sure that there are no cracks.
3. The purge button (26).  
Make sure there are no cracks.
4. Valve piston (8). Ensure that the ball joint is working correctly by manipulating and rotating the joint.
5. Operating device (14). Make sure that the joint articulates smoothly. Important: The operating device must be replaced, if the lever tab is bent. The tab should not be straightened, as this would weaken it and make subsequent failure possible.
6. Valve seat (5). Check to make sure the sealing surfaces are undamaged.
7. Low pressure hose (3). Check to make sure that the sealing surface is undamaged, and that the rubber does not show any flaws.
8. Diaphragm housing (22). Make sure that the sealing surfaces are free from defects and that the track for the inhalation diaphragm is absolutely clean and free from lubricant.

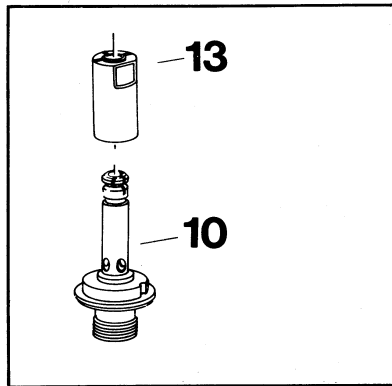

**Assembly:**

Install the ejector sleeve (13) on the valve housing (10). Press the sleeve into the low pressure valve so the slits of the sleeve are exceedingly small.

**Lubricate:**

Grease:     ◆

Oil:         △

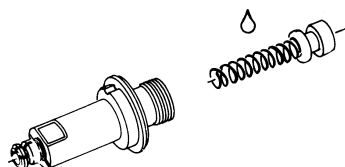
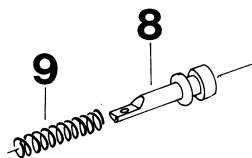
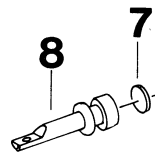
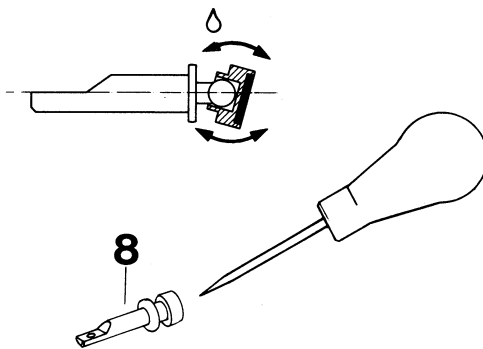
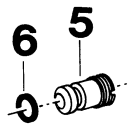
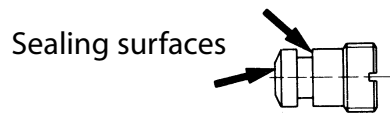

1. Install the o-ring (6) on the valve seat (5). Make sure that the sealing surface is not damaged.

2. Lubricate the ball joint. Tilt the position head according to the figure to ensure that it rotates and articulates smoothly.

3. Remove the rubber plate (7) with an awl and make sure the sealings surface on the valve is clean. Install the new rubber plate.

4. Put the spring (9) on the valve piston (8). Lubricate the spring

5. Install the valve piston/spring in the valve housing with the flat part of the valve piston upwards.

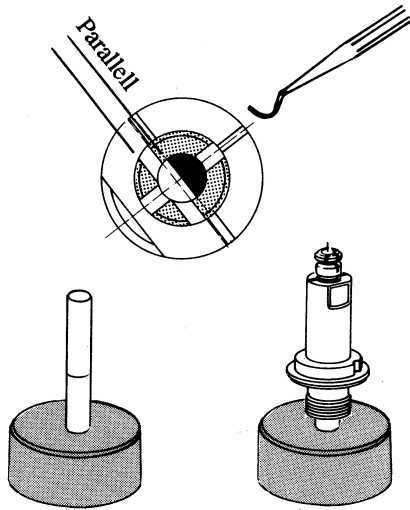

1. Place the valve housing on a drift seated on a block. Press the valve housing down, compressing the spring. Keep the flat part of the valve piston parallel with the horizontal slot in the end of the valve housing. Move the valve piston up and down a few times to check for freedom of movement.

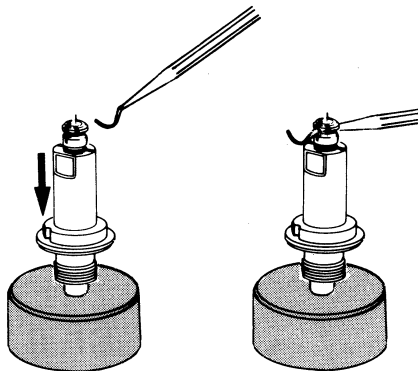

2. Press the valve housing down and slide an o-ring remover through the hole in the valve piston. See diagram.

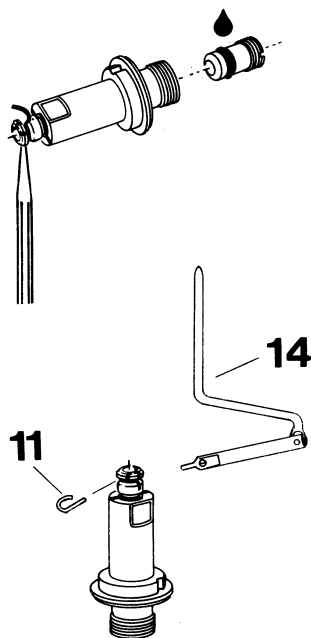

3. Lubricate the o-ring and the thread of the valve seat. Screw in the valve seat with an 8.5 mm screw driver until the o-ring remover comes loose.
4. Install the operating device (14). Insert the lever pin (11) through the slot, engaging the hole in the operating device. Rotate the lever pin 90 degrees to lock it in place.

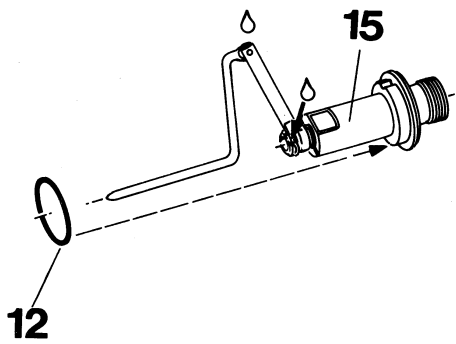

1. Install the o-ring (12).

Lubricate. See diagram.

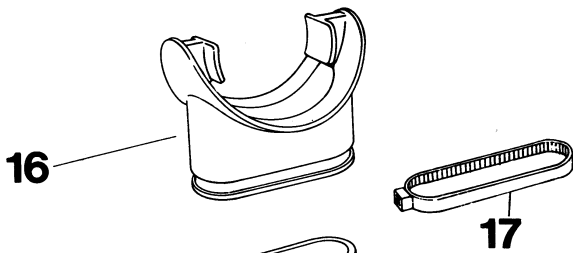

2. Install the mouth piece (16) and the plastic band (17). Tighten and cut off plastic band with plastic band pliers.

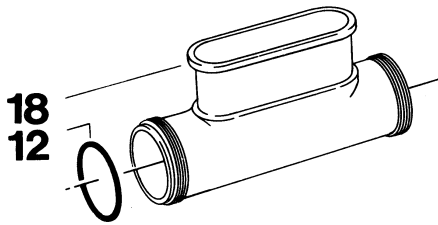

3. Install the o-ring (12)

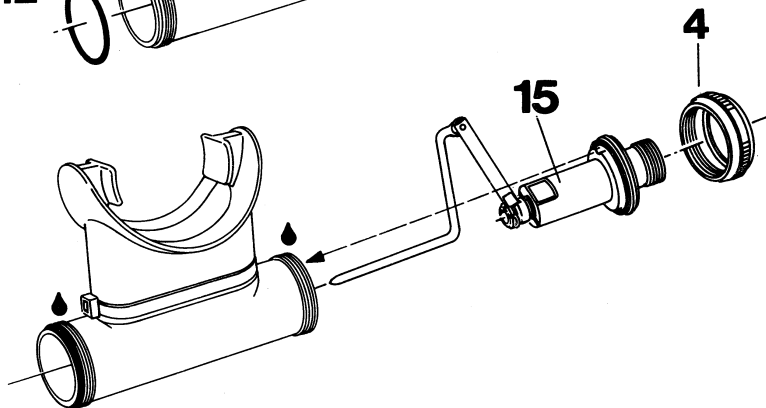

4. Lubricate the threads on the mouth piece

5. Install the low pressure valve (15) in the mouth piece tube. Set the indent notch at the top of the valve housing against the key at the top of the mouth piece tube. Screw on the connecting ring (4).

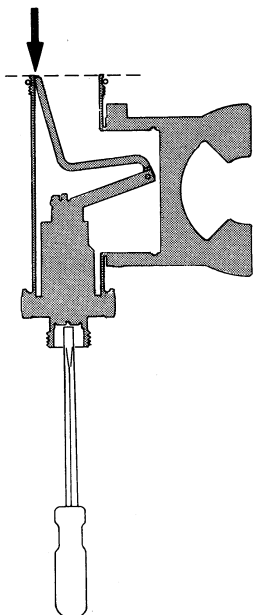

6. Screw the valve seat down until the highest part of the operating device is even with the level of the opening of the mouth piece tube. Hold the second stage valve vertically. See fig.

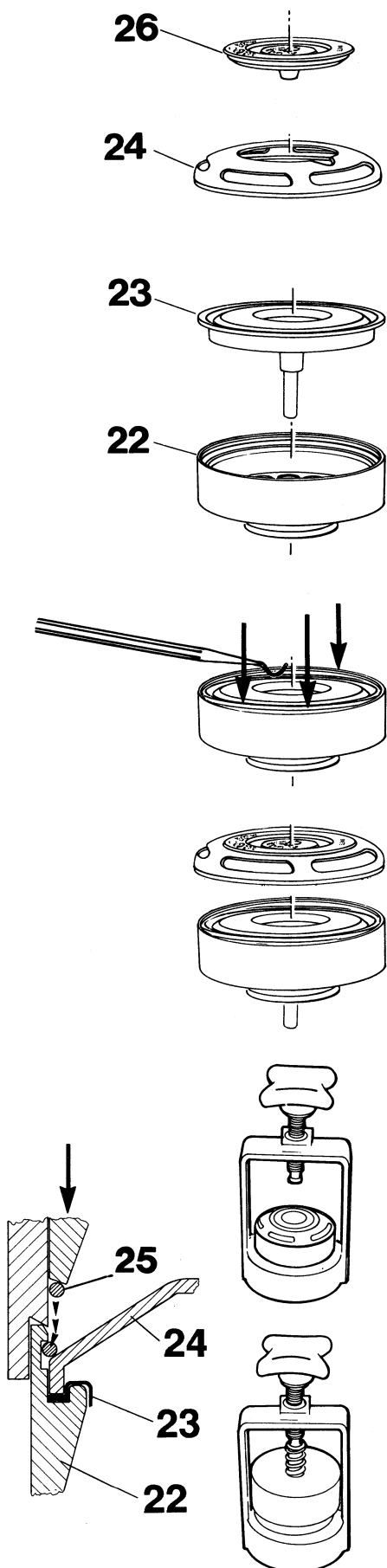

1. Install the purge button (26) in the cover (24).Screw the button in the cover-cavity
2. Install the inhalation diaphragm (23) on the diaphragm housing (22).
3. Seat the lip on the diaphragm into the recess on the inner rim of the diaphragm housing. Use an o-ring remover or other blunt pointed instrument.
4. Set the inhalation cover (24) on the diaphragm housing over the diaphragm.
5. Place the diaphragm housing complete with diaphragm and cover into the frame of the assembly tool.
6. Insert the locking ring (25) into the upper groove of the press of the assembly tool. See diagram
7. Place the press on top on the diaphragm housing.
8. Turn the knob until you hear or feel a slight click. Continue turning until you encounter resistance, then back off the knob to release the housing.
9. Check the locking ring placement to make sure that it has completely entered the groove.



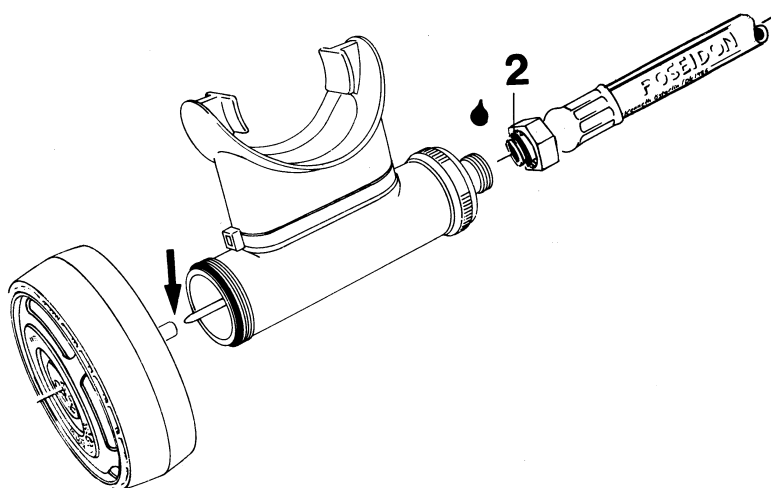
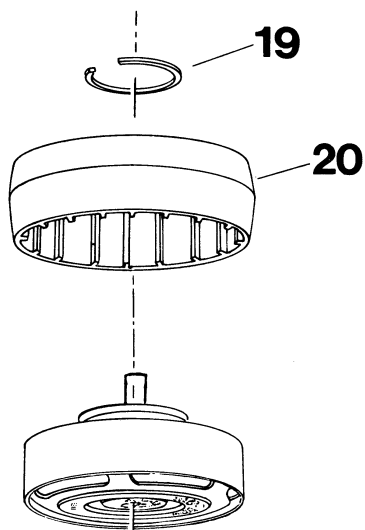
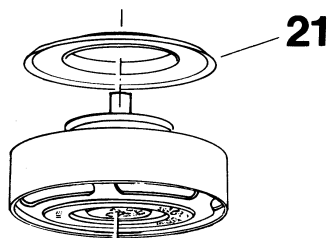

1. Install the exhalation diaphragm (21) on the diaphragm housing. Control that the diaphragm is packing on the diaphragm housing.
2. Install exhalation diaphragm cover (20) and locking ring (19).
3. Install the diaphragm housing on the mouthpiece tube. Be sure to slip the operating device into the diaphragm guide sleeve.
4. Checking the second stage for leaks: Place the mouth piece against your lips the low pressure hose correction with your thumb and inhale lightly. This will create a partial vacuum inside the second stage. If the pressure does not equalize in 5 seconds the second stage leaks. See chapter Fault-tracing scheme.
5. Install the o-ring (2) on the LP hose and lubricate
6. Screw on the LP-hose. Do not tighten the connecting ring until after the function test.

# REPAIR INSTRUCTIONS FIRST STAGE REDUCING VALVE

EXPLODED VIEW  
Art. No. 2305, 2422, 3070

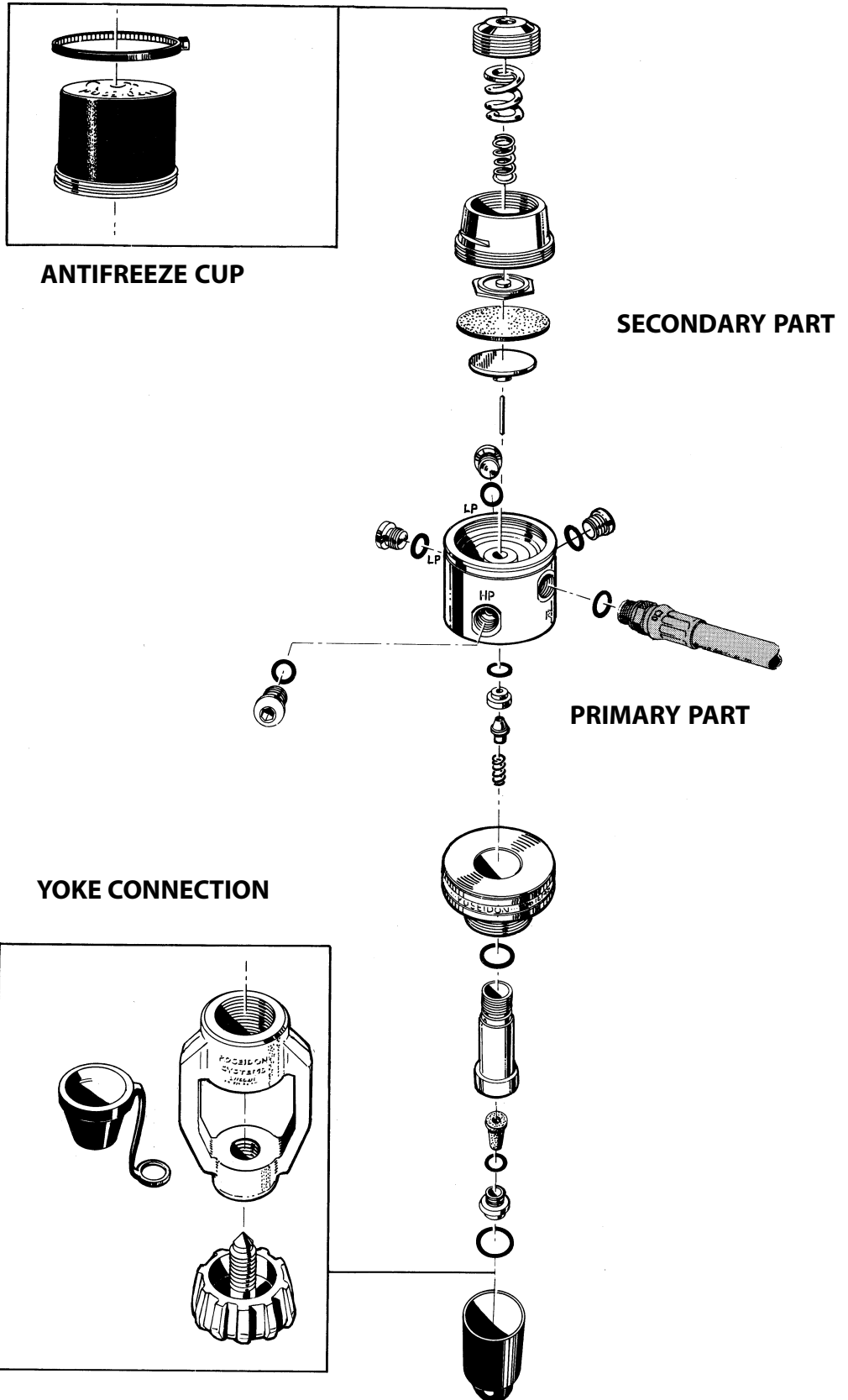

## FIRST STAGE VALVE 2305, 2422, 3070

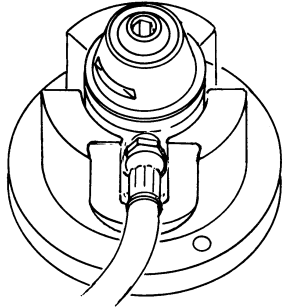

### Secondary side: Removal:

Place the first-stage valve in fixture with the secondary side facing upwards.

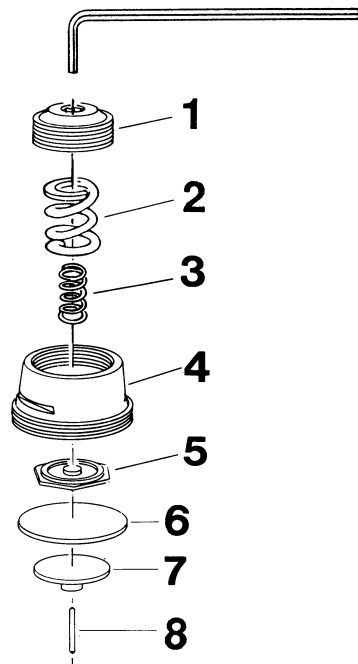

1. Remove the pressure adjusting screw (1) with a 6 mm hexagon spanner, and remove the spring (2) and (3).
2. Remove the cover (4) using a 27 mm crowsfoot wrench. Remove the upper diaphragm center (5).
3. Remove the diaphragm (6) with an o-ring remover. Make sure the sealing surface is not damaged. Remove the lower diaphragm center (7) and the valve needle (8).

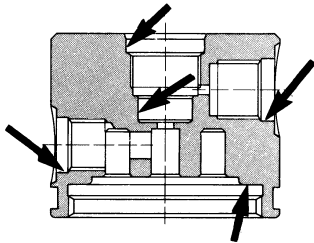

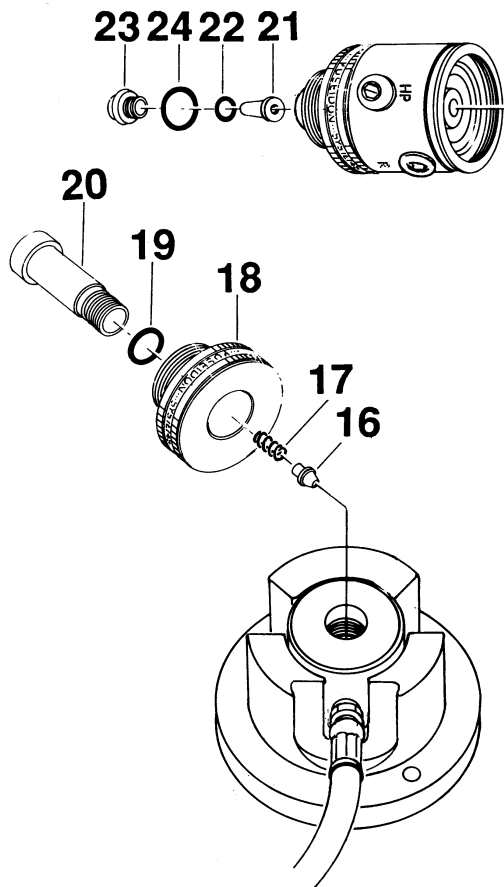

## FIRST STAGE 3070 (2422)

1. Remove the locking screw (23) with a 6 mm Allen wrench. 20 Remove the o-ring (24), cup filter (21) and o-ring (22).
2. Place the first stage in the fixture. Remove the connection (20) with 6 mm Allen wrench.
3. Remove the wheel (18) and the o-ring (19) with an o-ring remover. Make sure the sealing surfaces are not damaged.
4. Remove the spring (17) and the valve piston (16).
5. Disconnect the low pressure hose from the first-stage valve with a 13 mm open-end wrench.
6. Remove the o-ring from the low pressure hose. Make sure the sealing surfaces are not damaged.

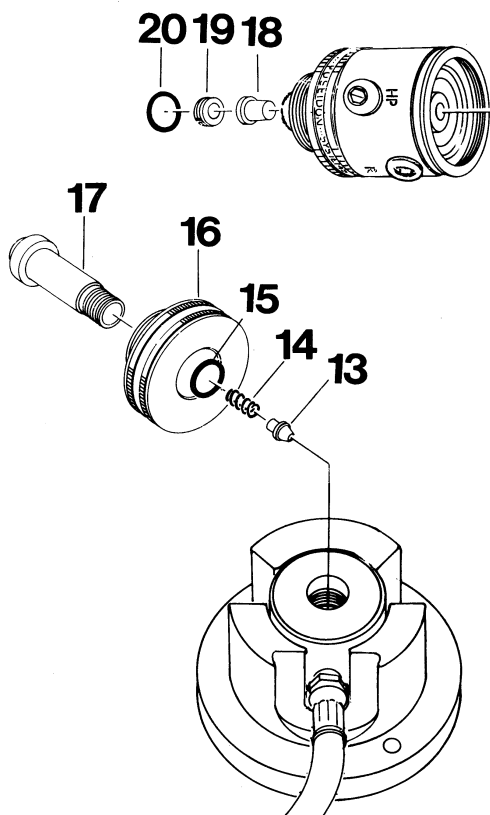

## FIRST STAGE 2305

1. Remove the o-ring (20) with an o-ring remover. Make sure the sealing surfaces are not damaged.
2. Remove the locking screw (19) with a 8.5 mm screwdriver. Remove the cup type filter (18).
3. Place the first stage housing in the fixture. Remove the connection (17) using a 6 mm Allen wrench.
4. Remove the o-ring (15) with an o-remover. Make sure the sealing surfaces are not damaged.
5. Remove the wheel (16).
6. Remove the spring (14) and the valve piston (13).
7. Disconnect the low pressure hose from the first stage valve with a 13 mm openend wrench.
8. Remove the o-ring from the low pressure hose. Make sure the sealing surfaces are not damaged.

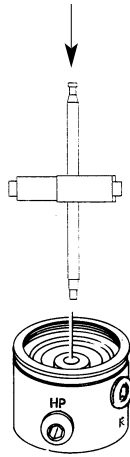

- 14 —  O-ring
  - 15 —  Valve seat
- Sealing surfaces

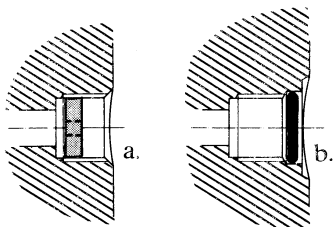
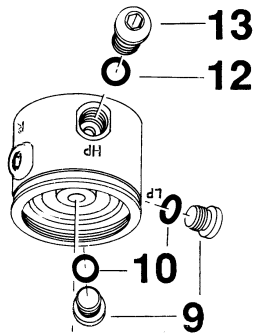
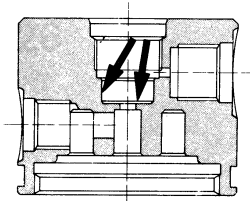

- a. G1/8"-port with gasket.
- b. UNF 3/8"-port with o-ring

1. Remove the valve seat (15) with the valve seat remover.
2. Remove the o-ring (14) with an o-ring remover. Make sure that the sealing surfaces are not damaged.
3. Remove the blind screws (9) and (13) with a 5 mm Allen wrench. Remove the o-rings with an o-ring remover. Make sure that the sealing surfaces are not damaged.

Old-type fist stage valve housings with (G 1/8") threads are equipped with nylon gaskets seats. It is not normally necessary to change these seats during service. However, if the seats are subjected to a great deal of over-tightening, the interior orifices can be reduced in diameter, significantly reducing flow and performance. Compare installed gasket orifices with a new gasket, and replace as necessary. Gaskets must also be replaced after a long time acid-bath.

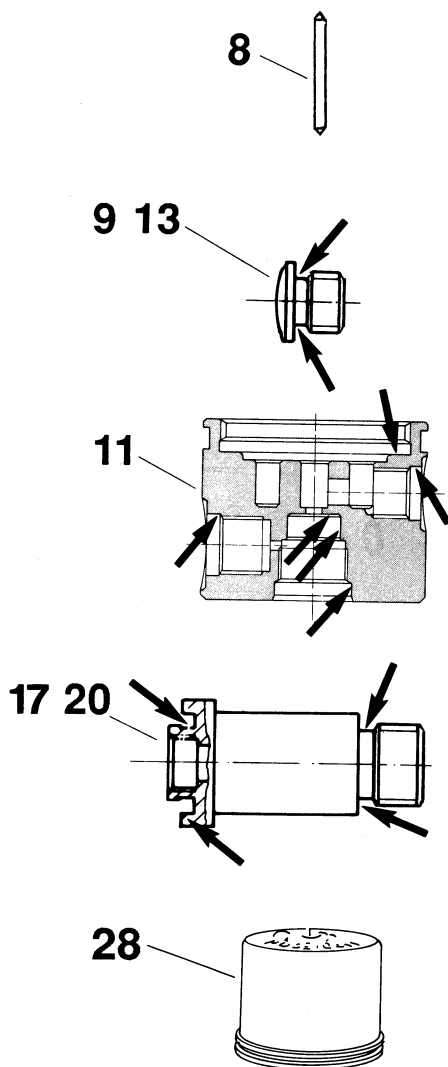

When servicing the regulator following parts should be replaced:

See chapter Servicekit.

1. All o-rings
2. Diaphragm
3. Cup filter
4. Valve seat

**Cleaning:**

If corrosion or salt deposits are in evidence, place all metal parts in 15 percent hydro-chloric acid. They should be left in the acid for about 10-15 minutes. Then, rinse the parts thoroughly and blow dry with air.

**SERVICE INSTRUCTIONS**

**Checking:**

Check the following parts very carefully. Replace even if only slightly damaged.

Valve needle (8). Check to make sure that the needle is straight.

The blind screws (9) and (13), check to make sure the sealing surfaces are undamaged. Also check that the threads are not damaged.

The valve housing (11), check to make sure the threads and also the sealing surfaces for the o-rings are undamaged.

The connections (17) or (20), check to make sure the sealing surfaces for the o-rings are undamaged.

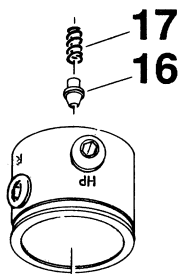
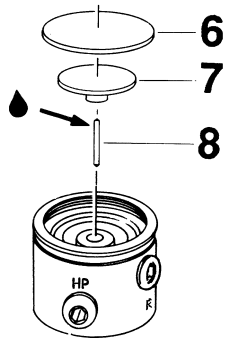
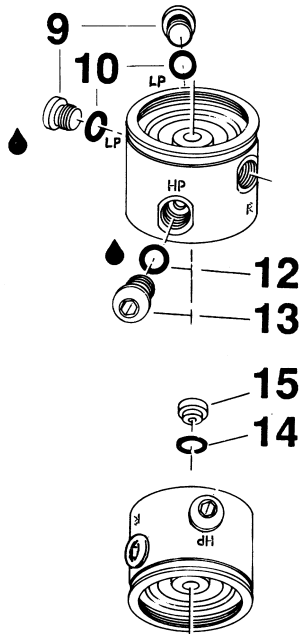

## Assembly

### Lubricant:

Grease: 

1. Install the o-ring (10) on the blind screws (9), low pressure supply and the o-ring (12) on the blind screw (13), high pressure supply. Lubricate the blind screws and the o-rings.
  2. Screw in the blind screws in the LP-HP outlets. Use a 5 mm Allen wrench and tighten hard.
  3. Install the o-ring (14) on the valve seat (15) and then install the valve seat with a seat drift.
  4. Lubricate the point of the valve needle (8) and install it in the lower diaphragm center (7). (The grease will help retain the needle on the lower diaphragm center during the assembly process).
  5. Install needle (8) and center (7) in the valve housing.
  6. Press the diaphragm (6) into the groove of the valve housing. Use a blunt-pointed instrument to set it firmly in place.
- NOTE:**  
The diaphragm (6) must be replaced on every removal.
7. Reverse the valve housing.
  8. Install the valve piston (16) on the valve needle.
  9. Install the spring (17) on the valve piston.

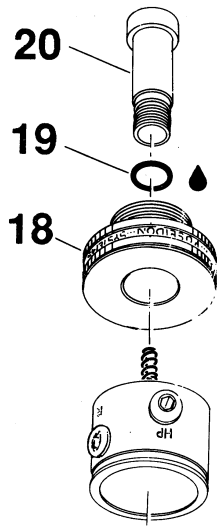

## FIRST STAGE 3070, 2422

1. Install the o-ring (19) on the connection housing (20). Lubricate the o-ring and the thread
2. Install the wheel (18) on the connection (20).
3. Screw the wheel connection assembly into the valve housing assembly with a 6 mm Allen wrench. Reverse the valve housing. Check the movement of the valve piston by pressing hard on the diaphragm. The movement should be about 1.5 mm (1/16").

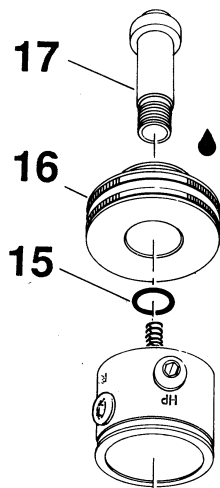

## FIRST STAGE 2305

1. Install the wheel (16) on the connection (17). Install the o-ring (15) on the connection (17). Lubricate the o-ring and the thread
2. Screw the wheel connection assembly into the valve housing assembly with a 6 mm Allen wrench. Reverse the valve housing. Check the movement of the valve piston by pressing hard on the diaphragm. The movement should be about 1.5 mm (1/16").



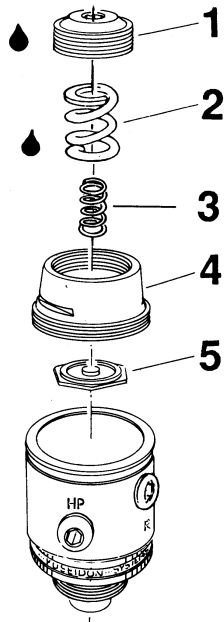

1. Place the upper diaphragm center (5) on the diaphragm in the valve housing.
2. Screw the cover (4) into the valve housing.
3. Lubricate both ends of the spring (2) and (3). Lubricate the threads on the pressure adjusting screw(1).
4. Tighten the pressure adjusting screw about 5 turns with a 6 mm Allen wrench.

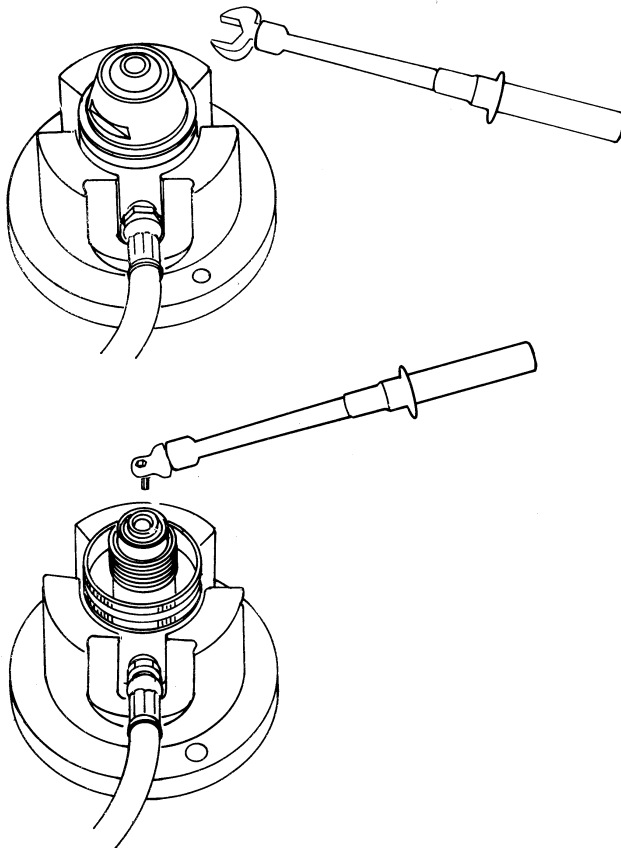

Place the stage assembly in the fixture. Tighten the valve housing cover with a 27 mm crowsfoot and the connection with a 6 mm Allen wrench. use a torque wrench to achieve 28-30 Nrn (20-22 lbf.ft) of torsion.

**IMPORTANT NOTE:** Use the right bits: To all first stages with wheel connection, bits No. 3119 (length 40 mm) should be used.

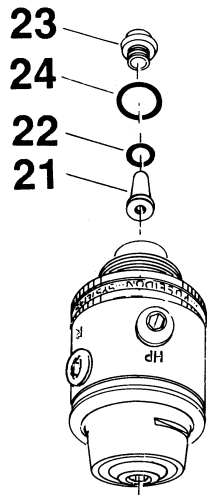

## FIRST STAGE 3070, 2422

1. Install the o-ring (22) on the cup type 21), then install the locking screw and o-ring (23). Tighten with a 6 mm Allen wrench.

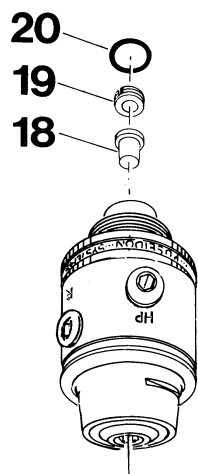

## FIRST STAGE 2305

1. Install the cup filter (18) and the locking screw (19) with a 8.5 mm screwdriver. Install the o-ring (20).

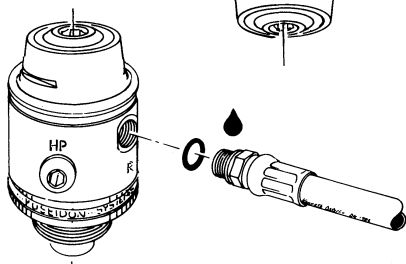

2. Install the o-ring (9) on the LP hose. Lubricate the o-ring and the thread. Tighten the hose nipple with a 13 mm openend wrench.

### INSTALLMENT OF ANTIFREEZE CAP

1. Check valve cover for correct tightness - 28-30 Nm.(20-22 lbf.ft)
2. Blow the inside of the valve cover clean and dry.
3. Then fill the valve cover and the rubber with pure spirit (alcohol, vodka) or water/glycol mixture. 3/4 fill.
4. Install the anti-freeze cap and fasten it with the locking band.

## OLD TYPE

For assembly of old-type spring housing, please note the following:

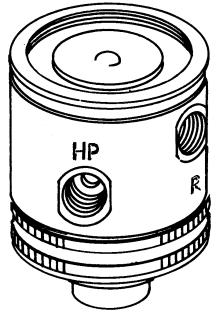

1. The upper diaphragm centre must be centered in the middle part.

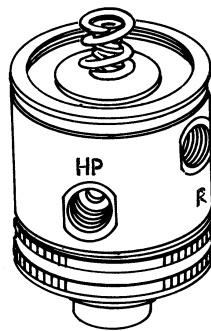

2. The inner and outer secondary springs shall be set in the middle.

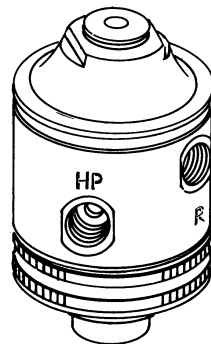

3. Screw carefully on the cover with assembly screw.
4. Tighten the valve housing cover with a special tool No. 2318. Use a torque wrench to achieve 28 Nm (20 lbf.ft).

# REPAIR INSTRUCTIONS FIRST STAGE REDUCING VALVE

EXPLODED VIEW

Art. No. 2801, 2808, 2962, 3257, 3580, 3585

JETSTREAM - YOKE

CYKLON 5000 - YOKE

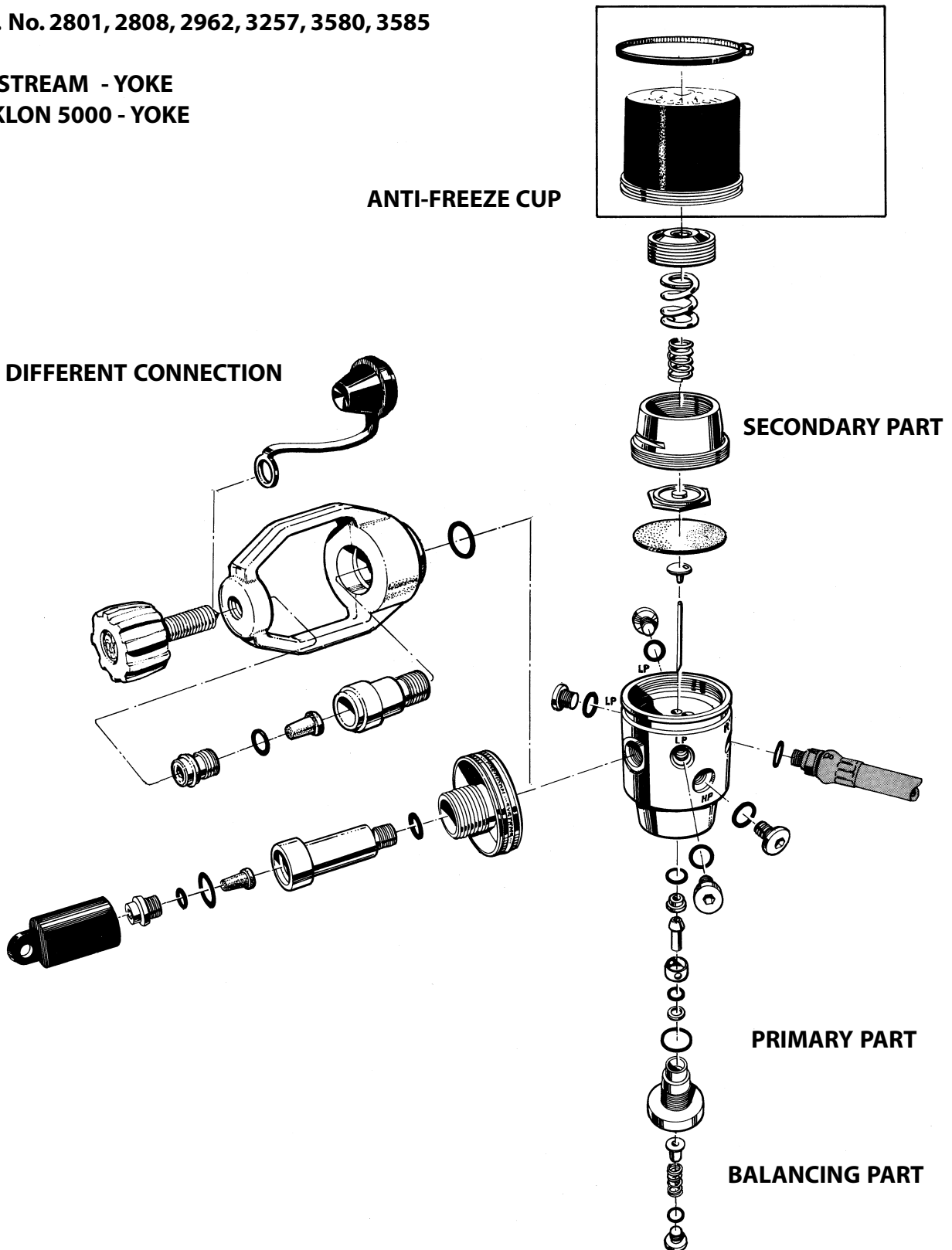

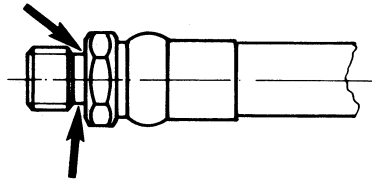

## FIRST STAGE VALVE 2801, 2808, 2962, 3257, 3580, 3585

### Secondary side:

1. Disconnect the low pressure hose from the first stage valve using a 13 mm open end wrench.
2. Remove the o-ring from the low pressure hose. Make sure the sealing surfaces are not damaged.

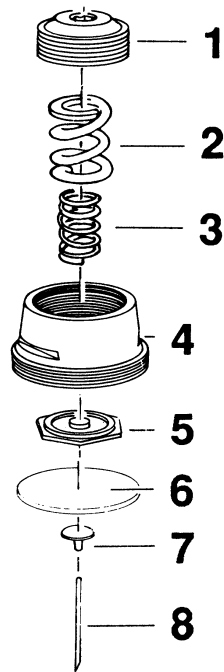
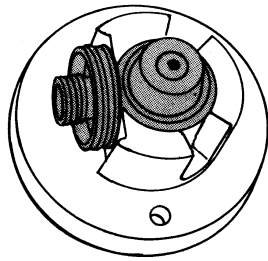

### Removal:

Place the first stage valve with the secondary side facing upwards in the fixture.

1. Remove the pressure adjusting screw (1) with a 6 mm Allen wrench and remove the spring (2) and (3).
2. Remove the cover (4) using a 27 mm crowsfoot and the upper diaphragm centre (5).
3. Remove the diaphragm (6). Make sure the sealing surface is not damaged. Remove the lower diaphragm centre (7) and the valve needle (8).

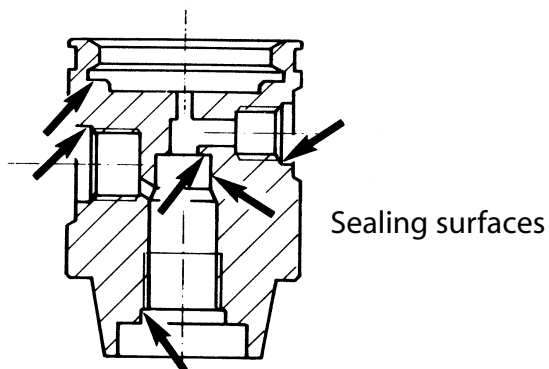

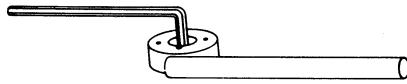

## BALANCE HOUSING

### Removal:

Place the first-stage valve with the balanced housing facing upwards.

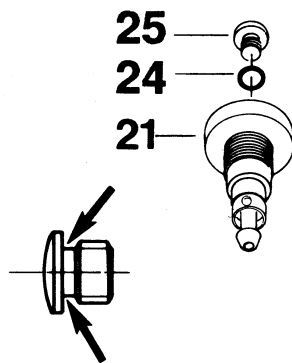

1. Steady the balance housing with a special wrench. Then remove the blind screw (25) with a 5 mm Allen wrench. Remove the o-ring (24) with an o-ring remover. Remove the balance housing (21) with the special wrench.

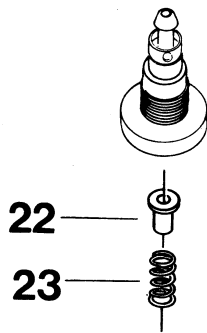

2. Remove the spring (23) and the spring guidance (22).

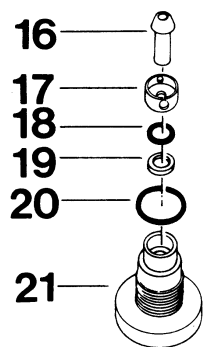

3. Remove the valve piston (16) and the spacing sleeve (17). Remove the o-ring (18) with an o-ring remover. Remove the washer (19) and the o-ring (20). Use an o-ring remover for this also. Make sure the sealing surfaces are not damaged.

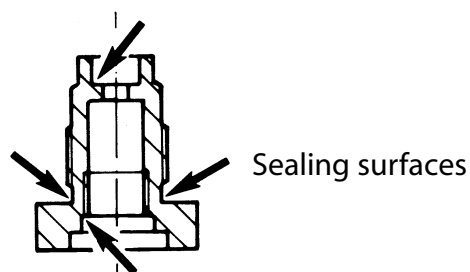

## FIRST STAGE 2962, 3257, 3580, 3585

### Removal:

1. Remove the protective cap (26).
2. Remove the locking screw (27) with a 6 mm Allen wrench. Remove the o-ring (28) and the cupfilter (30).
3. Place the first stage in the fixture. Remove the connecting (31) with a 6 mm Allen wrench.
4. Remove the wheel (33) and the oring (32) with an o-ring remover. Make sure the sealing surfaces are not damaged.

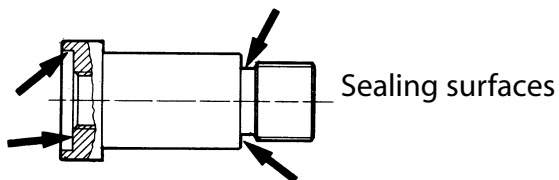
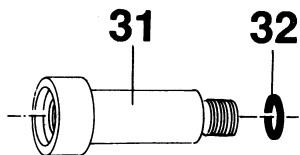
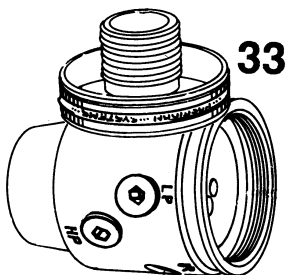
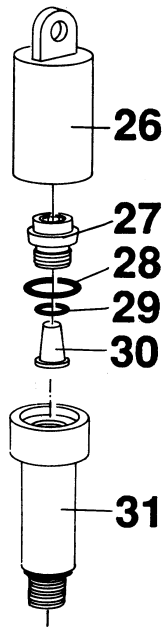

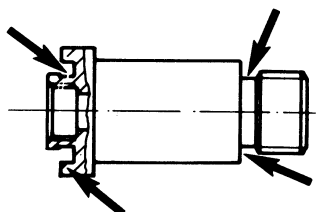
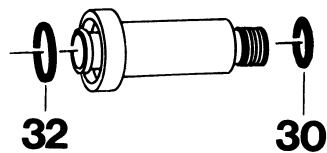
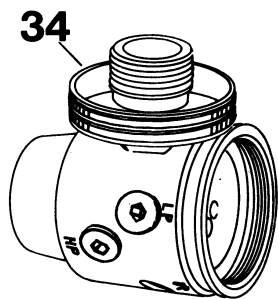
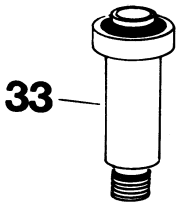
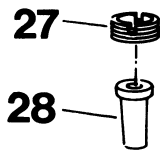
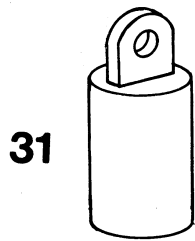

Sealing surfaces

## FIRST STAGE 2801

### Removal:

1. Remove the protective cap (31).
2. Remove the locking screw (27) with an 8.5 mm screwdriver. Remove the cup filter (28).
3. Place the first stage in the fixture. Remove the high pressure valve housing (33) with a 6 mm Allen wrench.
4. Remove the wheel (34).
5. Remove the o-rings (30,32) with an o-ring remover. Make sure the sealing surfaces are not damaged.



## FIRST STAGE 2801, 3257 10, 3585 10

### Removal:

1. Remove the protective cap (24).  
Unscrew the knob (25).

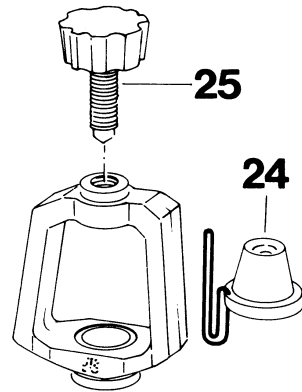

2. Remove the locking screw (27)  
with an 8.5 mm screwdriver.  
Remove the cup filter (28).

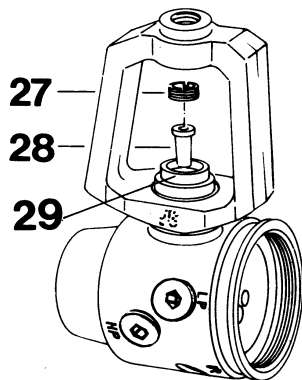

3. Remove the connection (29)  
with a 6 mm Allen wrench.

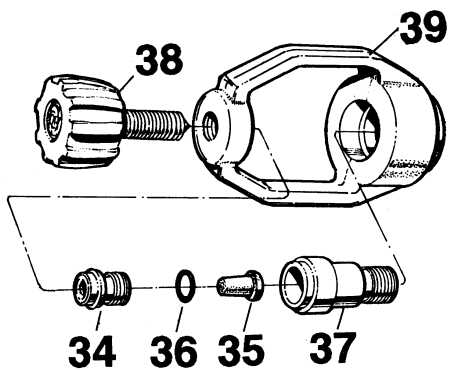

4. New model, remove the locking  
screw (34) with an 6 mm Allen  
wrench. Remove the cup filter  
(35) and the o-ring (36). Remove  
the connection (37) with an 6  
mm Allen wrench.

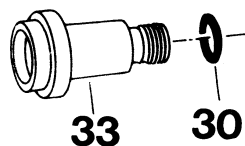

5. Remove the o-ring (30) with an  
o-ring remover. Make sure the  
sealing surface is not damaged.

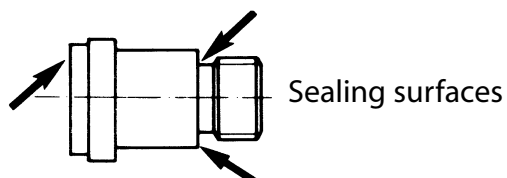

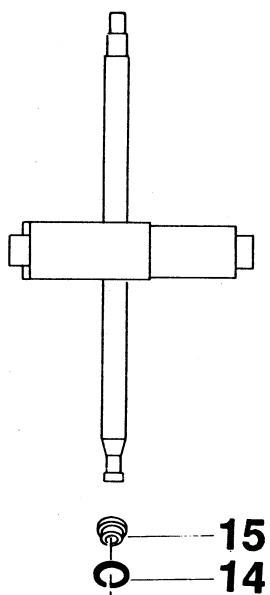

**FIRST STAGE**  
**2801, 2808, 2962, 3257,**  
**3580, 3585**

6. Remove the valve seat (15) with a valve seat remover.

7. Remove the o-ring (14) with an oring remover. Make sure the sealing surface is not damaged.

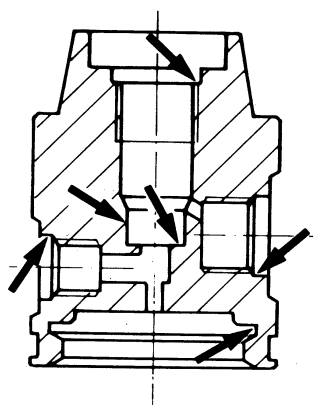
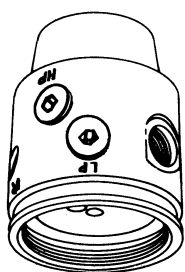

8. Remove the valve housing from the fixture.

9. Remove the blind screw (10 and 13) with a 5 mm and 3 mm Allen wrench. Remove the o-rings (9 and 12) with an o-ring remover. Make sure the sealing surfaces are not damaged.

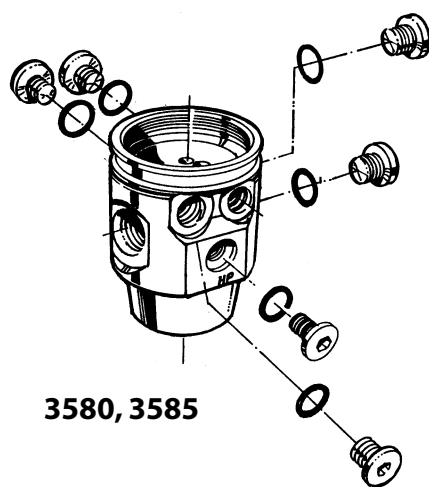
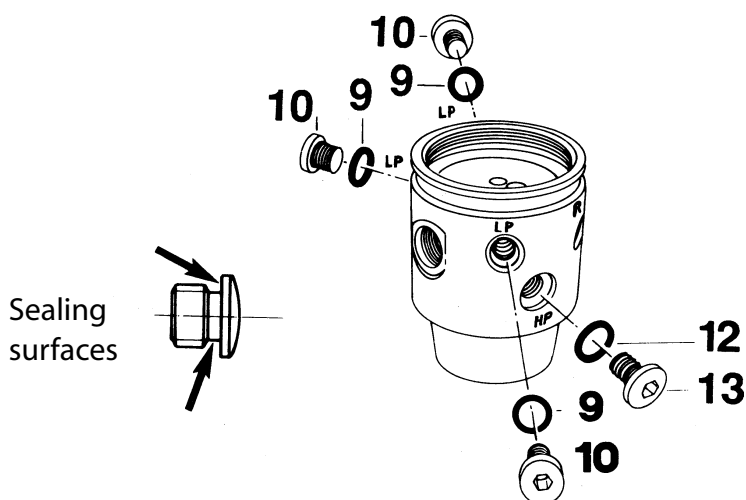

**3580, 3585**

---

When servicing the regulator the following parts should be replaced:  
See chapter Service-kit.

1. All o-rings
  2. Diaphragm
  3. Cup filter
  4. Valve seat
  5. Washer
- 

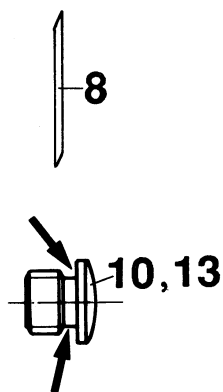

### **CLEANING:**

If corrosion or salt deposits occurs, place all metal parts – concentrated Hempocid\* or 15% Hydrochloric acid for about 10 minutes. Then, rinse the parts thoroughly and blow dry with air. The synthetic parts in the second stage must not be treated with solvent. They shall be cleaned in freshwater only.

*\*Hempocid = Acid Liquid Detergent Containing phosphoric acid (5 - 10%) and bactericid for disinfectant cleaning.*

### **Checking:**

Check the following parts very carefully. Replace even if only slightly damaged.

1. Valve needle (8). Check to make sure that the needle is straight.
2. The blind screws (10 and 13). Check to make sure the sealing surfaces are undamaged. Also check that the threads are not damaged.

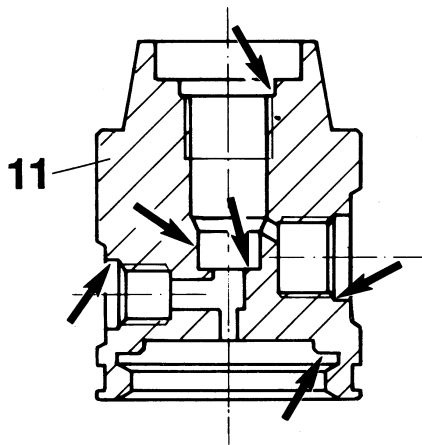

3. The valve housing (11).  
Check to make sure the threads and also the sealing surfaces for the o-rings are undamaged.

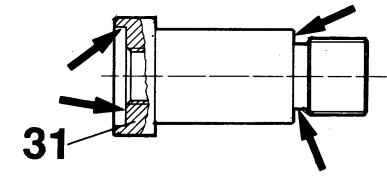
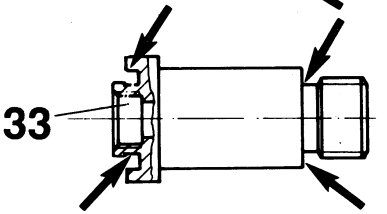
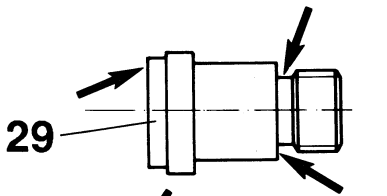

4. The connections (29,31 or 33).  
Check to make sure the sealing surfaces for the o-rings are undamaged.

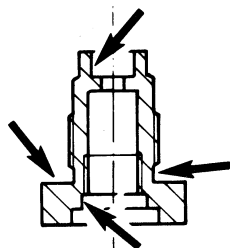

5. Balanced housing (21).  
Check to make sure the threads and also the sealing surfaces for the o-rings are undamaged.

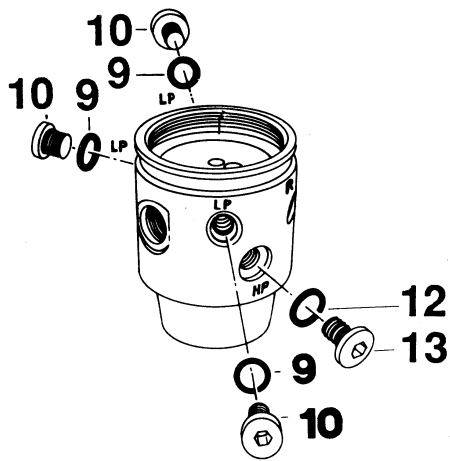

## Assembly

1. Install the o-rings (9) and (12) on the blind screws (10) and (13). Lubricate through the outlets.

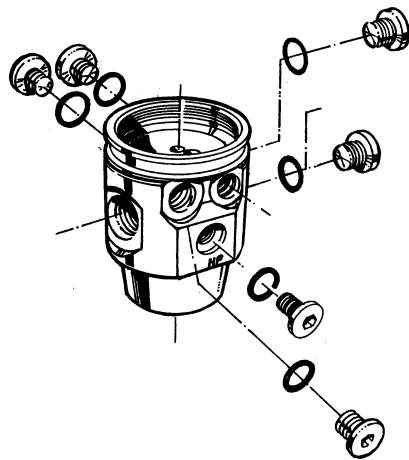

2. Screw in the blind screws in the LP- HP outlets. Use a 5 mm Allen wrench and tighten up by hand.

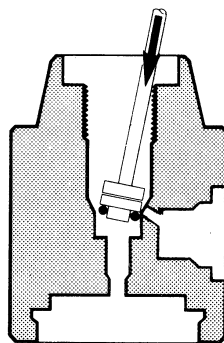

3. Install the o-ring (14) on the valve seat (15) and the install the valve seat with a seat drift. Press the drift diagonally as shown in the diagram and the "rock" it to the vertical while pressing down. The seat and o-ring should pop into place. This procedure avoids damage to the oring from the high pressure supply outlet.

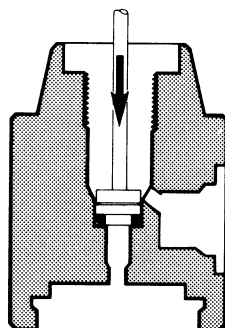

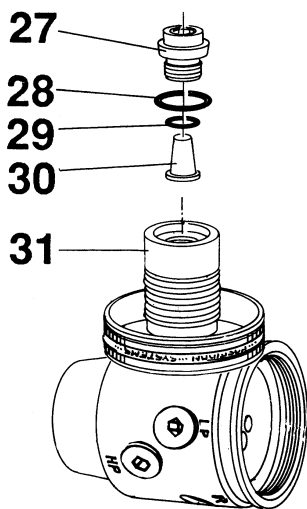
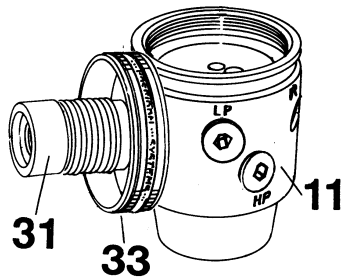
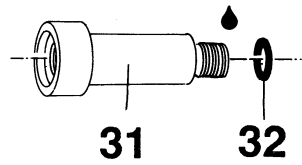

## FIRST STAGE 2962, 3257, 3580, 3585

### Assembly:

1. Install the o-ring (3 1) on the connection (30). Lubricate the o-ring and the thread.
2. Install the wheel (33) on the connection.
3. Screw the wheel connection assembly into, the valve housing assembly with a 6 mm Allen wrench.

Place the valve housing (11) in a fixture. Tighten with a torque wrench to 28 - 30 Nm (20-22 lbf. ft.).

**IMPORTANT!** Use bits No 3119 (L = 40 mm). Put o-ring (29) on the cup type filter (30). Install these and o-ring (28) and the locking screw (27) in connection (31). Tighten with a Allen wrench 6 mm.

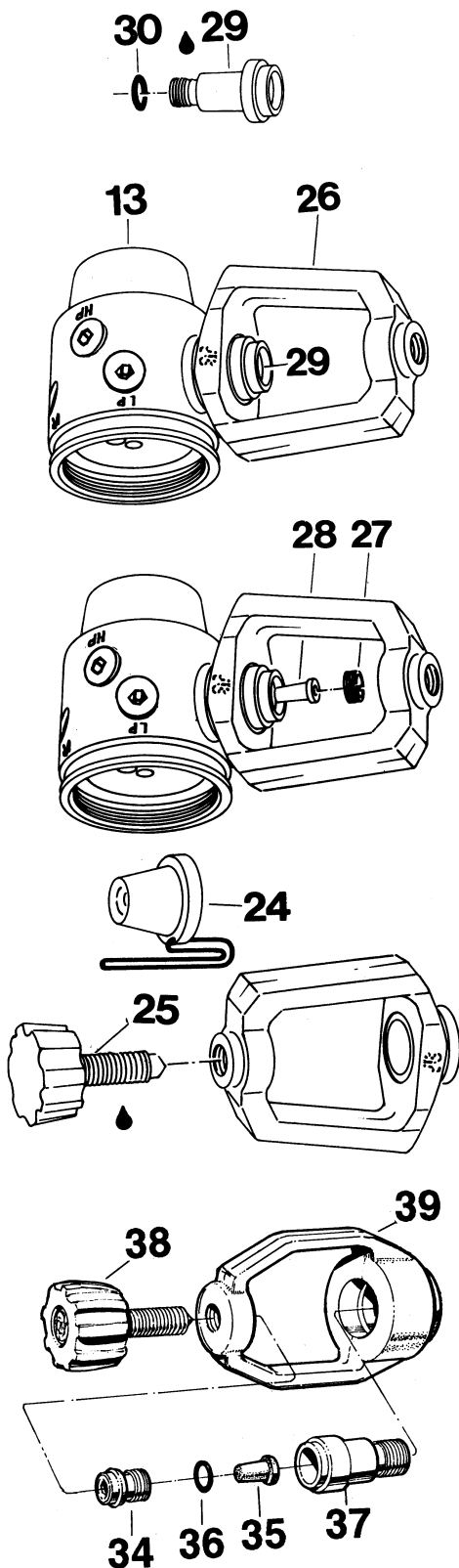

## FIRST STAGE 2801, 3257 10, 3585 10

### Assembly:

1. Install the o-ring (30) on the connection (29). Lubricate the thread and the o-ring.
2. Place the connection (29) in the Yoke (26) and screw the connection into the valve housing (13) using a 6 mm Allen wrench. Place the valve housing in a fixture. Tighten with a torque wrench to 28 - 30 Nm.(20-22 lbf.ft). Use bits nr 2883 (length 30 mm)
3. Install the cup filter (28). Screw in the locking screw (27) with a 8.5 mm screw driver. Install the protective cap (24).Grease the thread and screw in the knob.
4. New model. Place the connection (37) in the Yoke (39) and screw the connection into the valve housing, using a 6 mm Allen wrench. Place the valve housing in a fixture. Tighten with a torque wrench to 28 - 30 Nm (20 - 22 lbf.ft). Use bits nr 3119 (length 40 mm)
5. Install the o-ring(36) on the cup type filter(35). Place the filter in the connection(37).
6. Install the protective cap, grease the thread and screw in the knob.

## FIRST STAGE 2808

### Assembly:

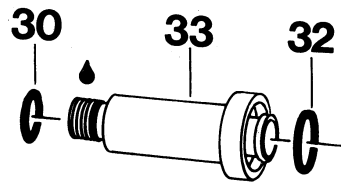

1. Install the o-rings (30,32) on the connection (33). Grease the o-ring (30) and thread.

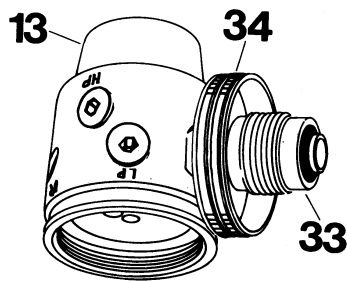

2. Fit the connection (33) to the wheel (34) and screw it into the valve housing (13) with a 6 mm Allen wrench. Place the valve housing in torque wrench to 28 - 30 Nm.(20-22 lbf.ft).

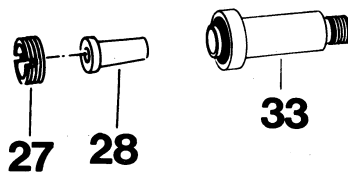

3. Install the cup filter (28) screw in the locking screw (27) with an 8.5 mm screwdriver.



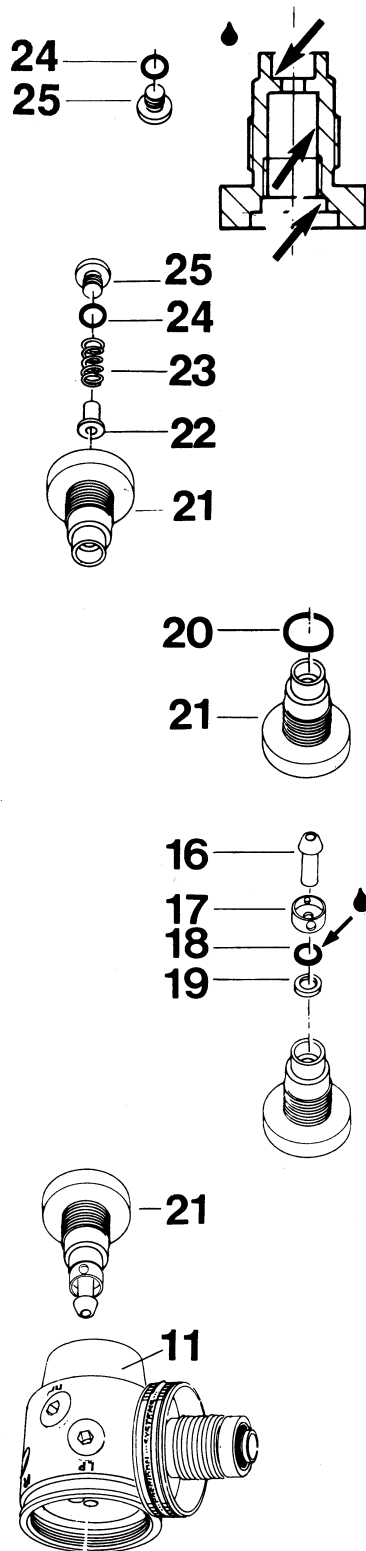

## FIRST STAGE

### BALANCED HOUSING

1. Install the o-ring (24) on the blind screw G 1/8" (25).
2. Grease the inside of balanced housing (21).
3. Install the spring guide (22) and the spring (23). Serew in the blind screw (11) with a 5 mm Allen wrench. The blind screw should be tightened while the balanced housing is held in the valve housing.
4. Install the o-ring (20) at the balanced housing .
5. Install the washer (19)and the oring (18). Grease the inside of oring and the washer. Install the spacing sleeve (17) and the valve piston (16).
6. Install the balanced housing (21) in the valve housing (11) and tighten the blind screw with a Allen wrench to 10Nm/7 lbf.ft.

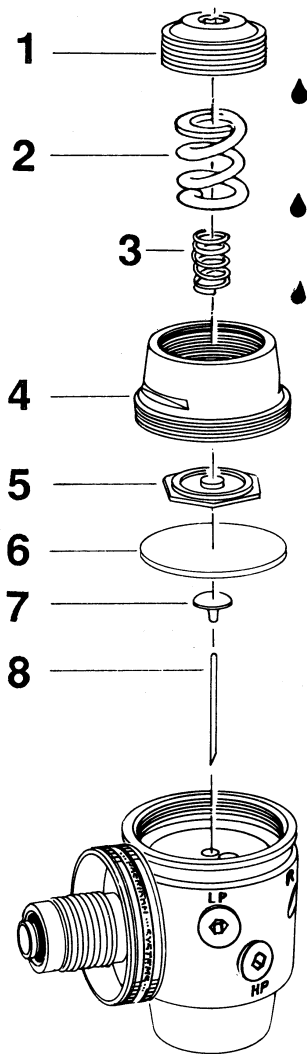

7. Turn the valve housing with the secondary side upwards.

8. Install the valve needle (10). At previous models the needle was beveled in one edge. The bevel should in these cases be pointed downwards.

9. Install the lower diaphragm centre (7) and the diaphragm (6), which must be pushed into the groove in the valve housing. Check to make sure that this is correctly installed by pressing it downwards. It should move approximately 2 mm (1/16").

10. Install the upper diaphragm centre (5).

11. Install the cover (4) and tighten with a torque wrench to 28 - 30 Nm. (20-22 lbf.ft).

12. Install the spring (2) and (3), lubricate both ends of the spring and the thread on pressure adjusting screw, and tighten 5 turns with a 6 mm Allen wrench.

# REPAIR INSTRUCTIONS FIRST STAGE REDUCING VALVE

3720  
3720 10

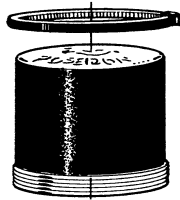

ANTI-FREEZE CAP

## DIFFERENT CONNECTIONS

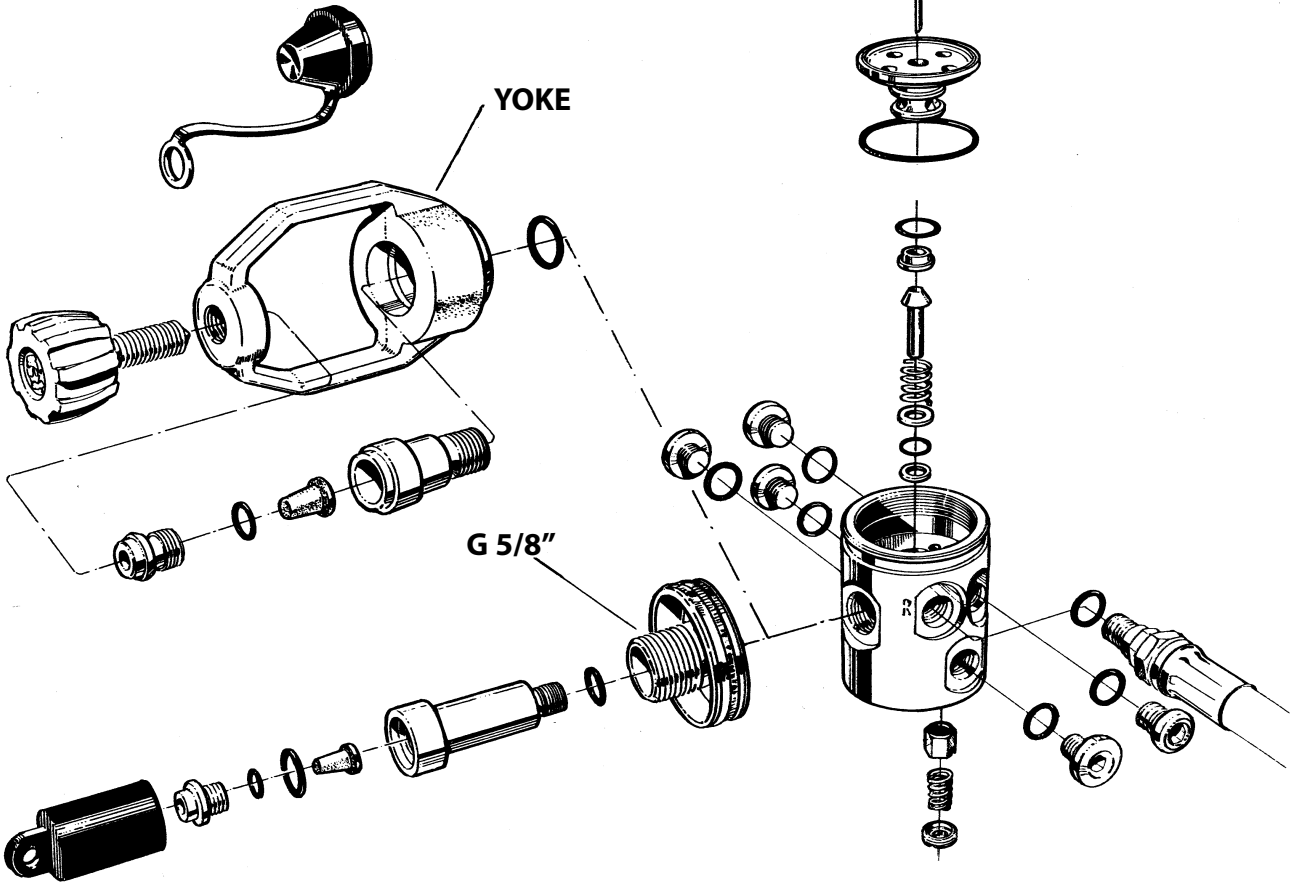

SAFETY VALVE

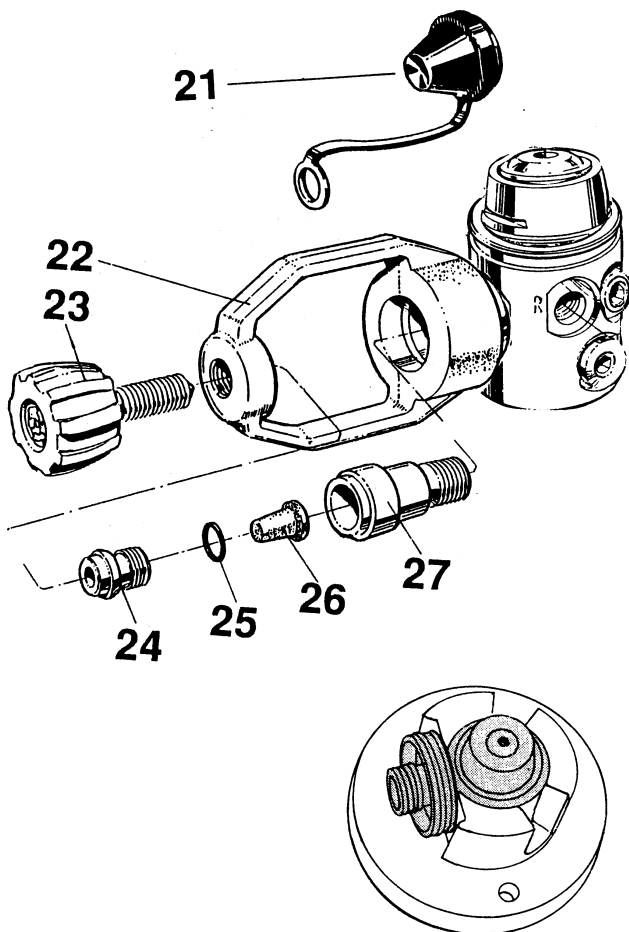
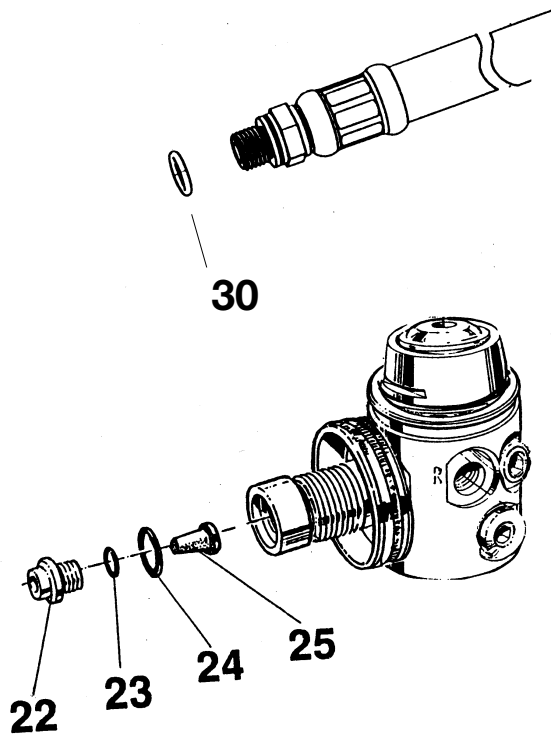

## FIRST STAGE VALVE 3720

### Secondary side:

1. Disconnect the low pressure hose from the first stage valve using a 13 mm box spanner.
2. Remove the o-ring (30) from the low pressure hose with the o-ring remover.

### First stage valve with G 5/8":

3. Remove the locking screw (22) with a 6 mm Allen wrench. Remove the o-ring (24) and the cup-filter (25) with o-ring (23).

### First stage valve with Yoke:

3. Remove the knob (23) and the protective cap (21). Remove the locking screw (24) with a 6 mm Allen wrench. Remove the cup filter (26) and the o-ring (25).
4. Place the first stage valve with the secondary side facing upwards in the fixture.

## FIRST STAGE VALVE 3720

### Removal:

1. Remove the pressure adjusting screw (1) with a 6 mm Allen wrench and remove the spring (2 and 3).
2. Remove the cover (4) using a 27 mm crowsfoot and the upper diaphragm center (5).

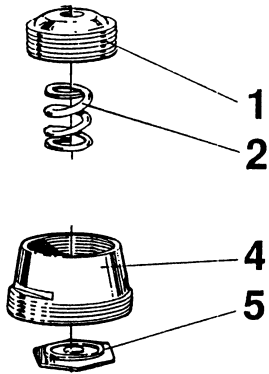

### First stage valve with G 5/8":

3. Remove the connection (26) and the wheel (28) with a 6 mm Allen wrench.
4. Remove the o-ring (27) with an o-ring remover. Make sure the sealing surfaces are not damaged.

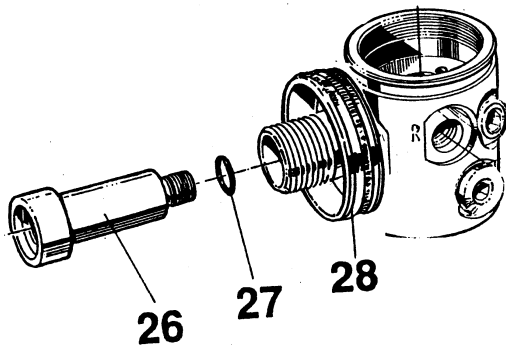

### First stage valve with Yoke:

3. Remove the connection (27) and the yoke (22) with a 6 mm Allen wrench.
4. Remove the o-ring (28) with an o-ring remover. Make sure the sealing surfaces are not damaged.

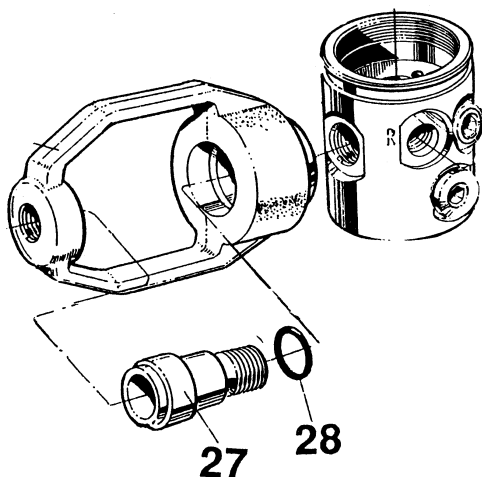

## FIRST STAGE VALVE 3720

### Removal:

1. Remove the valve centre, upper (6) and the diaphragm (7).
2. Remove the diaphragm centre, lower (8) and the valve needle (9).
3. Remove the valve centre, lower (10) and the o-ring (11) with an o-ring remover. Make sure the sealing surfaces are not damaged.
4. Remove the valve seat (14) and the o-ring (13) with the assembly drift A.
5. Remove the valve piston (15) and the pressure spring (16).
6. Remove the washer, steel (17), the o-ring (18) and the washer, teflon (19) with an o-ring remover. Make sure the surfaces, are not damaged.

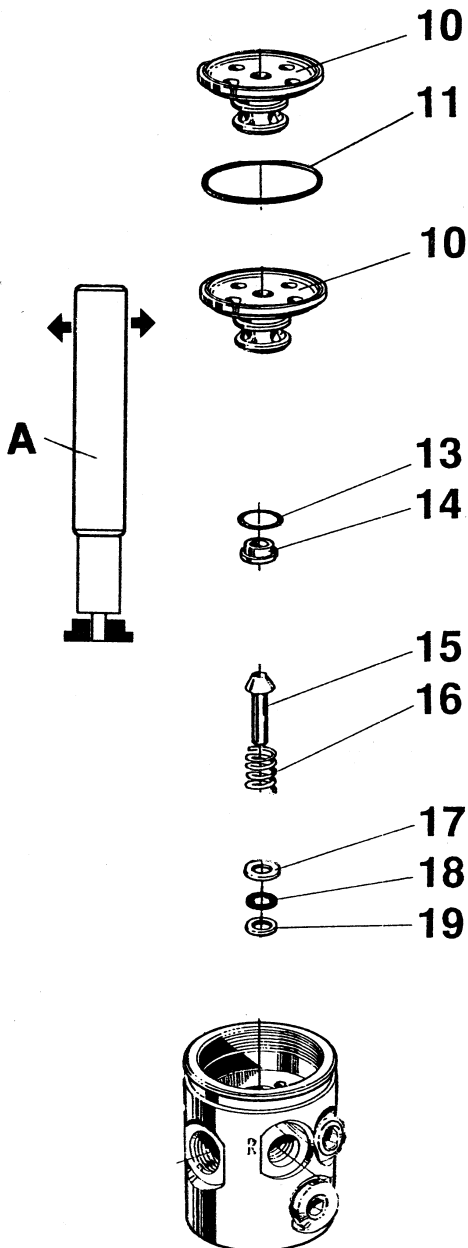

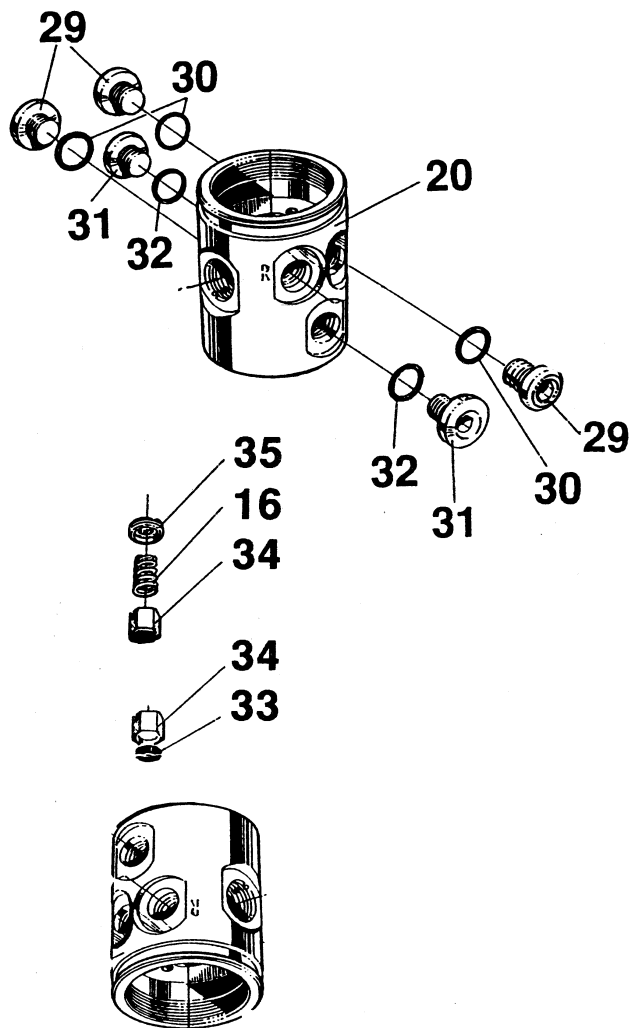

## FIRST STAGE VALVE 3720

### Removal:

1. Remove the blind screw (29 and 31) with a 5 mm Allen wrench. Remove the o-rings (30 and 32) with an o-ring remover. Make sure the sealing surfaces are not damaged.
2. Remove the locking screw (35) with a 4mm Allen wrench. Remove the pressure spring (16) and the valve piston (34).
3. Remove the valve sealing (33) from the valve piston (34) with an o-ring remover.

### Cleaning:

If corrosion or salt deposits occurs, place all metal parts in concentrated Hempodid\* or 15% Hydrochloric acid for about 10 minutes. Then rinse them thoroughly and blow dry with air. The synthetic parts in the second stage must not be treated with solvent. They shall be cleaned in freshwater only. \*Hempodid = Acid Liquid Detergent Containing phosphoric acid (5-10%) and bactericid for desinfectant cleaning.

## FIRST STAGE VALVE, 3720

**When servicing the regulator  
the following parts should be  
replaced:**  
(see chapter Servicekit)

1. All o-rings
2. Diaphragm
3. Cup filter
4. Valve seat
5. Washer
6. Valve sealing

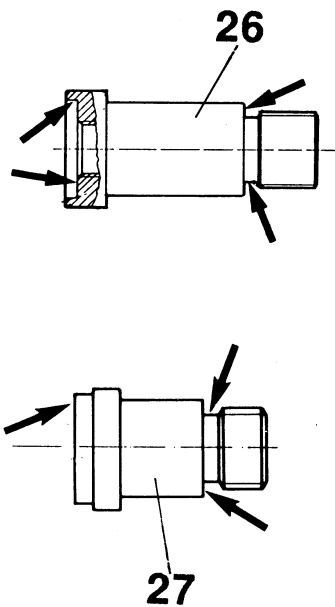
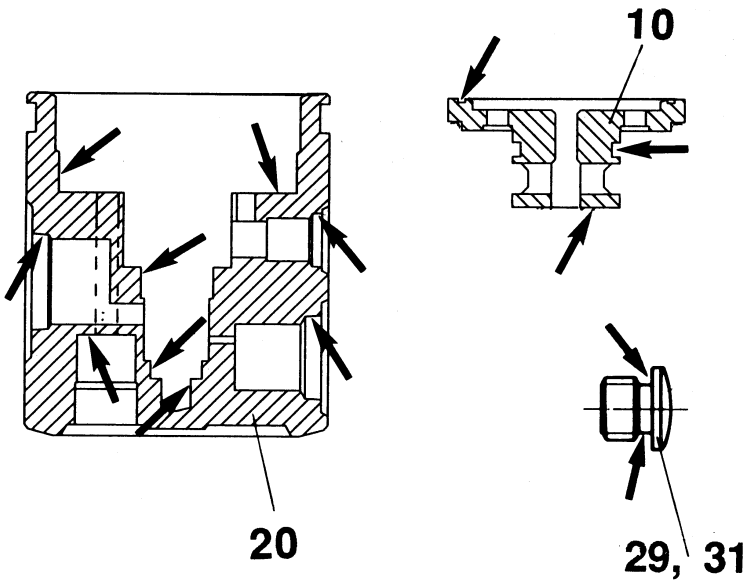

### Checking:

Check the following parts to make sure the sealing surfaces are undamaged. Also check that the threads are not damaged.

1. The blind screws (29 and 31)
2. The valve housing (20)
3. Valve centre (10)
4. The connections (26 or 27)



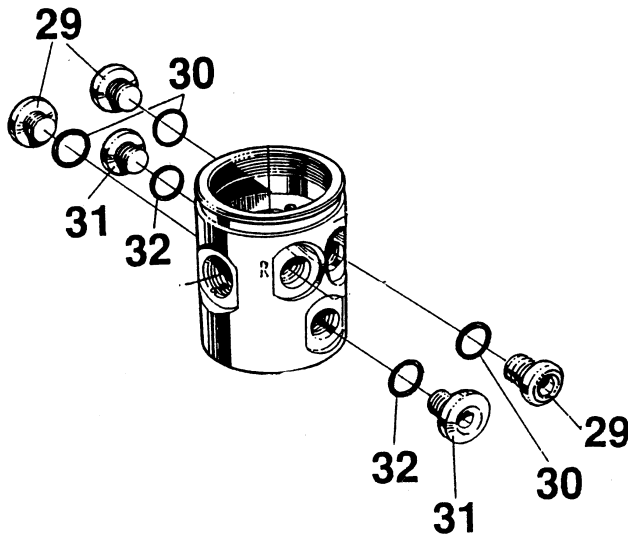

## FIRST STAGE VALVE 3720

### Assembly:

1. Install the o-rings(30 and 32) on the blind screws (29 and 31). Lubricate the outlets.
2. Screw the blind screws in the LP-HP outlets. Use a 5 mm Allen wrench and tighten up by hand.

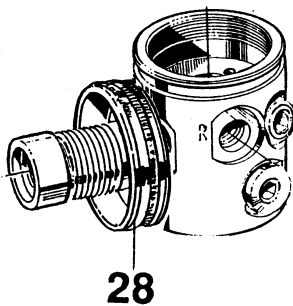
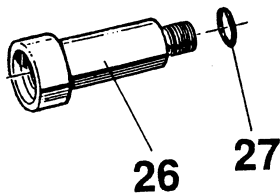

### First stage valve with G 5/8":

1. Install the o-ring (27) on the connection (26). Lubricate the o-ring and the thread.
2. Install the wheel (28) on the connection.
3. Screw the wheel connection assembly into the valve housing assembly with a 6 mm Allen wrench.

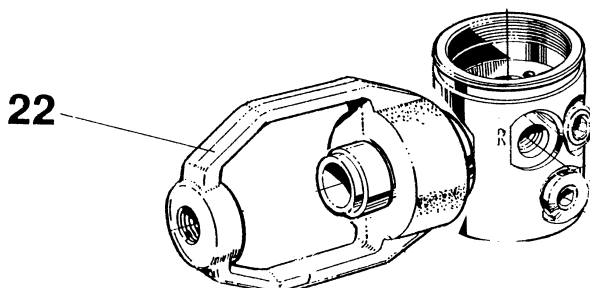
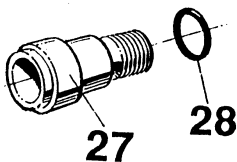

### First stage valve with Yoke:

1. Install the o-ring (28) on the connection (27). Lubricate the o-ring and the thread.
2. Install the yoke (22) on the connection.
3. Screw the wheel connection assembly into the valve housing assembly with a 6 mm Allen wrench.

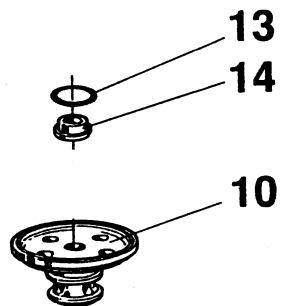
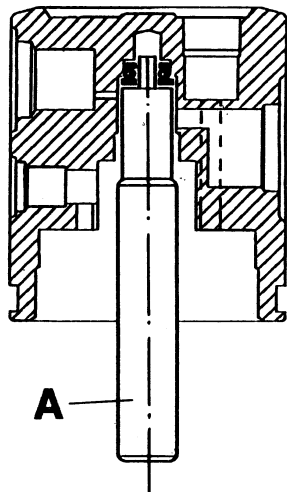
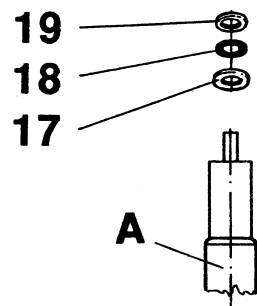
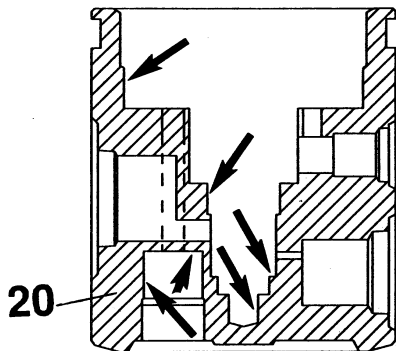

## FIRST STAGE VALVE 3720

### Assembly:

1. Lubricate the valve housing (20).

2. Place on the assembly drift A:

-washer, steel (17)

-O-ring (18)

-washer, teflon (19)

3. Install the valve housing.

Lubricate the washers

and the o-ring.

4. Install the o-ring (13) on the

valve seat (14).

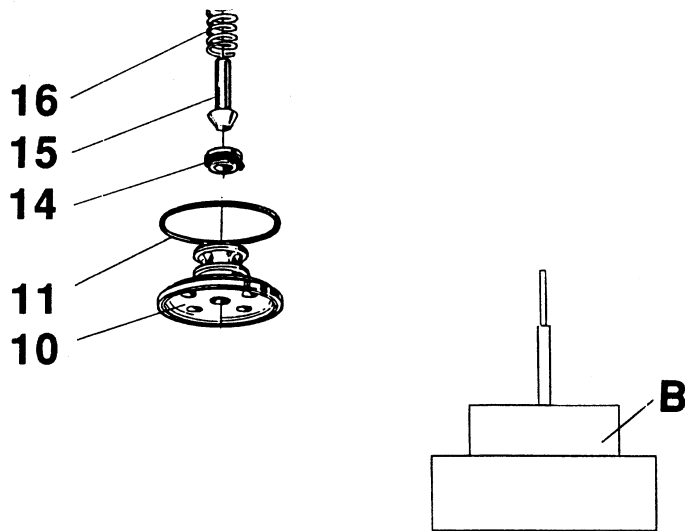

## FIRST STAGE VALVE 3720

### Assembly:

1. Place on the assembly fixture B:
  - valve centre, lower (10)
  - o-ring (11), lubricate
  - valve seat (14) with o-ring downwards
  - valve piston (15), lubricate, and pressure spring (16) on valve piston.

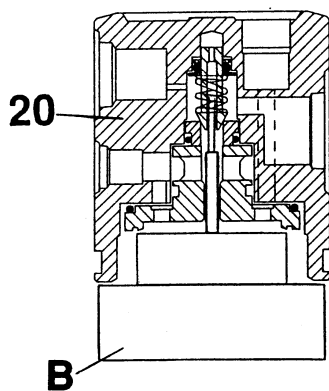

2. Install the valve housing (20).

3. Turn the valve housing (20) with the secondary side upwards.

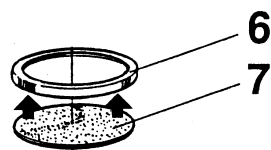

4. Install the valve needle (9).

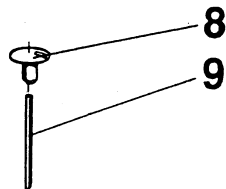

5. Install the lower diaphragm centre (8).

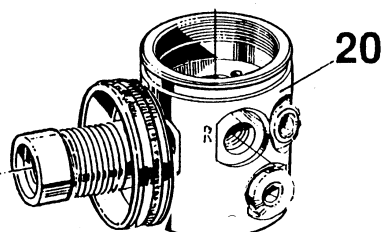

6. Install the diaphragm (7) in the valve centre, upper, convex part up (6). Install the valve housing (20).

## FIRST STAGE VALVE 3720

### Assembly:

1. Install the diaphragm centre, upper (5) in the valve housing (20).
2. Grease the thread on the cover (4) and tighten up by hand.
3. Check to make sure that the parts are correctly installed by pressing at the valve centre. It should move approximately 2 mm (1/16").
4. Lubricate both ends of the spring (2 and 3) and install. Lubricate the thread on pressure adjusting screw (1), and tighten 7 turns with a 6 mm Allen wrench.
5. Install the valve sealing (33) on the valve piston (34).
6. Install the valve piston (34) and the pressure spring (16). Install the locking screw (35) with a 4 mm Allen wrench. Tighten up by hand.

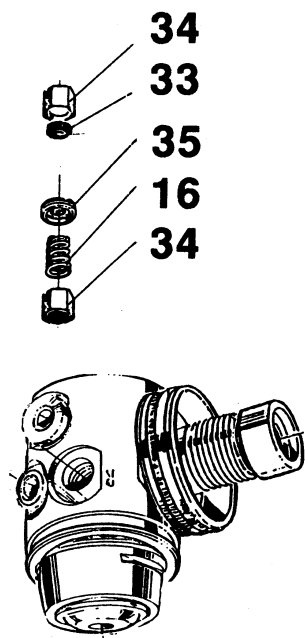
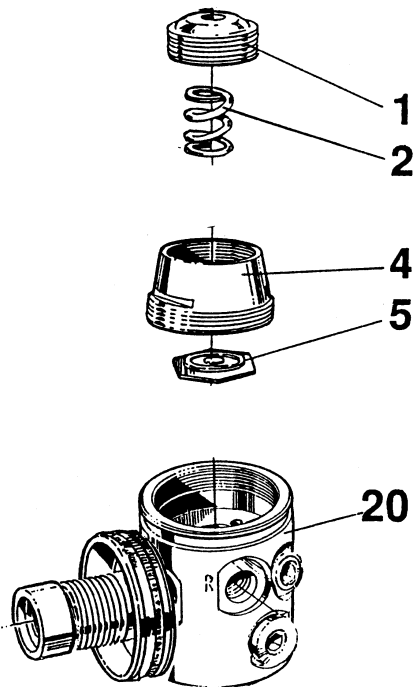

## FIRST STAGE VALVE 3720

### Assembly:

1. Place the valve housing (20) in a fixture.
2. Tighten the cover for valve housing with a torque wrench (30 Nm) and an open ended insert tool 27 mm.
3. Tighten the connection with a torque wrench (30 Nm) and holder insert tool/ bits.  
**IMPORTANT!** Use bits nr 3119 (L = 40 mm).

### First stage valve with G5/8":

4. Put o-ring (23) on the cup type filter (25). Install them and the o-ring (24) and the locking screw (22) in the connection (26). Tighten with a Allen wrench 6 mm.

### First stage valve with Yoke:

4. Put o-ring (25) on the cup type filter (26). Install them and the locking screw (24) in the connection (27). Tighten with a Wrench 6 mm. Put the protective cap (21) on the knob (23). Lubricate and screw in the knob.
5. Install o-ring (30) on the low pressure hose. Lubricate the o-ring and the thread. Tighten the hose with a 13 mm open wrench.

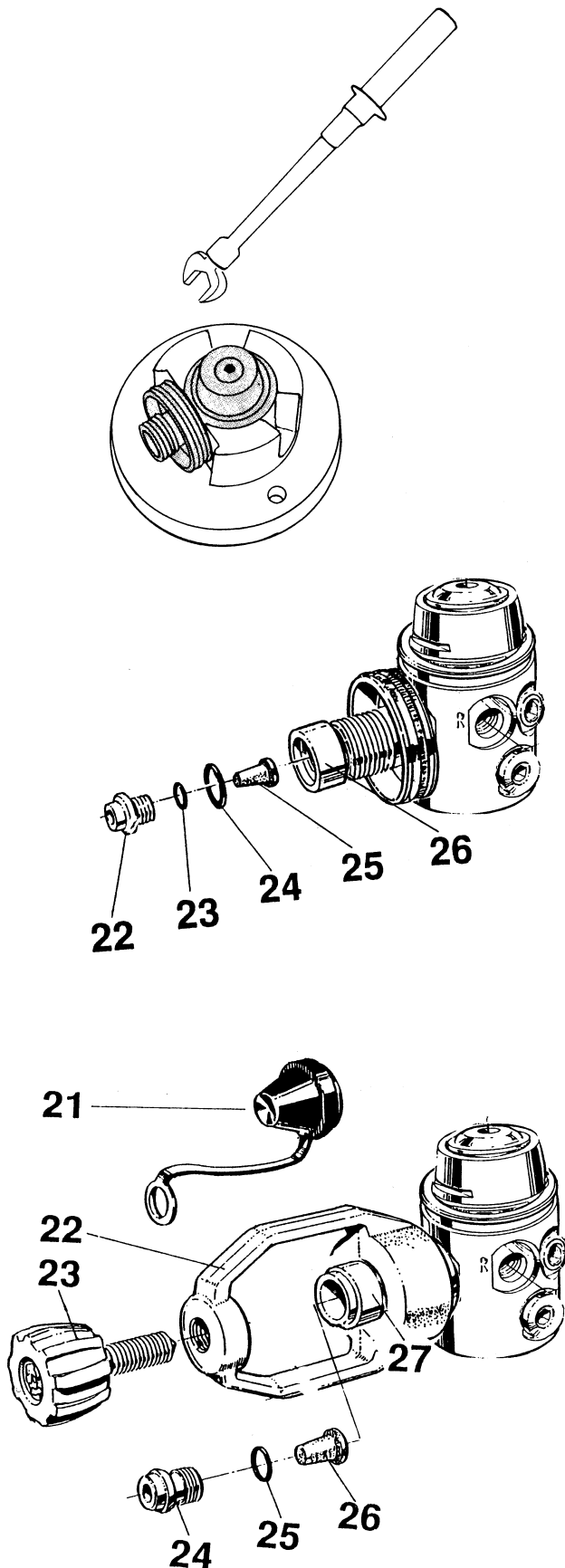

## TESTING AND ADJUSTMENT OF REGULATOR CYKLON 300 Art. No. 2980

### First stage valve:

1. Connect the regulator to the test equipment.
2. Connect the test manometer hose to one of the low pressure outlets.
3. Open the LP valve (=20 bar).
4. Set the secondary pressure at 11.5 bar, an intermittently purge the second stage by means of the purge button. NOTE that the second stage valve must be fully tight during this test. When the pressure gauge needle stops at the preset pressure, a maximum rise in pressure of 1 bar is allowed before the needle finally stops. Adjust the pressure to a maximum of 12.5 bar (the maximum pressure) taking into account any rise in pressure. If the needle continues to move to a higher pressure reading there is a fault in the seal between the valve seat and piston, or the O-ring.
5. Close the LP valve, and open the HP valve (=200/300 bar). Purge intermittently with the purge button, check the tightness, and adjust the pressure to 8.5-11.5 bar.
6. Close the LP valve and purge it fully.

### Second stage valve:

1. Open the LP valve. Check the secondary pressure. It should be between 12 and 12.5 bar.
2. Check to make sure that the clearance between the control unit and the low pressure valve is approximately 1mm. See ill. A. If the clearance is too small, do not seal the second stage valve. If the clearance is too large, reduce the flow of air and the inhalation resistance will increase.

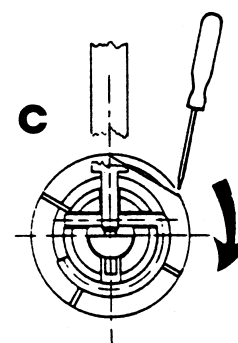
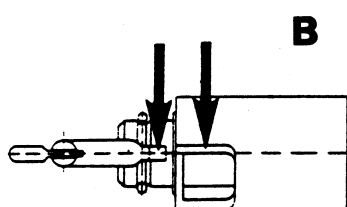
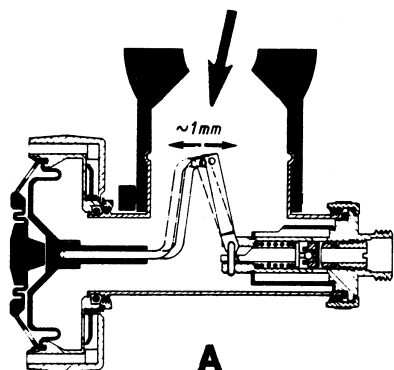

### Adjustment of the clearance:

1. Close the LP valve, and empty the regulator completely by means of the purge button.
2. Unscrew and remove the low pressure hose from the second stage valve.
3. If the clearance is too small, screw the valve seat inwards (clockwise) using an 8.5 mm screwdriver. If the clearance is too large, screw the valve seat outwards (counterclockwise). NOTE that the adjustment torque is very sensitive, so you should screw carefully. The clearance can be checked only when the secondary pressure is between 10 and 12.5 bar.
4. Fit the hose and open the LP valve. Check the clearance once again.
5. Close the LP valve.

### Adjustment of ejector sleeve:

1. Open the HP valve.
2. Turn the ejector sleeve using a 3.5 mm screwdriver as shown in ill. B so that the edge of the hole is opposite the slit in the low pressure valve. See ill. C. Hold the second stage valve upright, press the button so that the valve will give a maximum flow of air, and then release the button. If the valve continues to blow itself, stop the air flow using your hand. Turn the ejector sleeve in the direction of the arrow, see ill. B, and make a new test using the button. The opening of the hole should be turned to face upwards as much as possible, that is, close to the limit where the valve blows itself. The regulator will then give a maximum flow of air and the inhalation resistance is minimal.
3. Close the HP valve and purge fully with the purge button. Tighten the nut moderately.

# TESTING AND ADJUSTMENT OF REGULATOR CYKLON 5000 (DIVEAIR) Art. No. 2950, 3950

## First stage valve:

1. Connect the regulator to the test equipment.
2. Connect the test manometer hose to one of the low pressure outlets.
3. Open the LP valve (=20 bar)
4. Set the secondary pressure at 11.5 bar, an intermittently purge the second stage by means of the purge button. NOTE that the second stage valve must be fully tight during this test. When the pressure gauge needle stops at the preset pressure, a maximum rise in pressure of 1 bar is allowed before the needle finally stops. Adjust the pressure to a maximum of 11,5 bar (the maximum pressure) taking into account any rise in pressure. If the needle continues to move to a higher pressure reading there is a fault in the seal between the valve seat and piston, or the O-ring.
5. Close the LP valve, and open the HP valve (=200/300 bar). Purge intermittently with the purge button, check the tightness, and adjust the pressure to 9 - 10 bar.
6. Close the LP valve and purge it fully.

## Second stage valve:

1. Open the LP valve. Adjust the sec. pressure to 11,5-12,0 bar.
2. Check to make sure that the clearance between the control unit and the low pressure valve is approximately 1 mm. See ill. A. If the clearance is too small, do not seal the second stage valve. If the clearance is too large, reduce the flow of air and the inhalation resistance will increase.

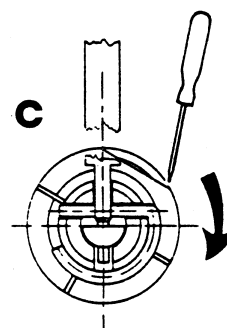
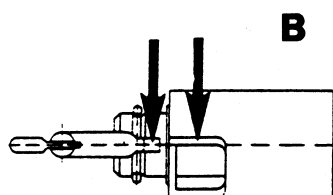
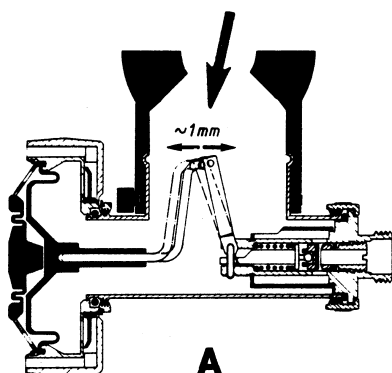

## Adjustment of the clearance:

1. Close the LP valve, and empty the regulator completely by means of the purge button.
2. Unscrew and remove the low pressure hose from the second stage valve.
3. If the clearance is too small, screw the valve seat inwards (clockwise) using an 8.5 mm screwdriver. If the clearance is too large, screw the valve seat outwards (counterclockwise). NOTE that the adjustment torque is very sensitive, so you should screw carefully. The clearance can be checked only when the secondary pressure is approx 10 bar.
4. Fit the hose and open the LP valve. Check the clearance once again.
5. Close the LP valve.

## Adjustment of ejector sleeve:

1. Open the HP valve.
2. Turn the ejector sleeve using a 3.5 mm screwdriver as shown in ill. B so that the edge of the hole is opposite the slit in the low pressure valve. See ill. C. Hold the second stage valve upright, press the button so that the valve will give a maximum flow of air, and then release the button. If the valve continues to blow itself, stop the air flow using your hand. Turn the ejector sleeve in the direction of the arrow, see ill. B, and make a new test using the button. The opening of the hole should be turned to face upwards as much as possible, that is, close to the limit where the valve blows itself. The regulator will then give a maximum flow of air and the inhalation resistance is minimal.
3. Close the HP valve and purge fully with the purge button. Tighten the nut moderately.

## **Poseidon Triton 2000**

### **BREATHING REGULATOR**

**Art. No 3750**

Primary pressure nominal .....	4350 PSI / 30 MPa / 300 bar
Secondary pressure .....	Max. 152 PSI / 1,0 MPa / 10 bar
Air flow .....	Approx. 1100 l/min
Inhalation resistance .....	Max. 40 mm of water /400 Pa /40 mm/vp
Exhalation resistance .....	Max. 20 mm of water /200 Pa /20 mm/vp

*The above data apply when measuring at atmospheric pressure*

### **FIRST STAGE VALVE**

**Art. No 3720, 3720 10**

Description.....	Diaphragm-actuated balanced with shear venturi boost. Release pressure approx. 217-247 PSI / 1,5-1,7 MPa / 15-17 bar
Connecting thread for primary pressure.....	G 5/8" -max 4350 PSI / 30 MPa / 300 bar accord. SS 2600/K and DIN 477/5 or yoke connection accord. SS 2603 and ANSI/CGA V1: 1987

Outlet connections:

One outlet marked R for second stage (max. airflow).....	UNF 3/8" -secondary pressure
Three outlets marked LP for Triton octopus, drysuits, stabjacket.....	UNF 3/8" -secondary pressure
Two outlet marked HP for pressure gauge.....	UNF 7/16" -primary pressure

### **SECOND STAGE VALVE**

**Art. No 3755**

Description, downstream .....	Diaphragm-actuated, servo assisted, fixed ejector system. Purge button for clearing.
-------------------------------	--

### **REGULATOR HOSE**

**Art. No 3735**

Length.....	70 cm
-------------	-------

### **TIGHTENING TORQUE**

Primary connection, valve cover .....	22 lbf.ft / 30 Nm /3,0 kpm
Connections marked R-LP-HP.....	6 lbf. ft / 8 Nm / 0,8 kpm

### **ANTI-FREEZE PROTECTION**

**Art. No 1286**

Type .....	Rubber cap
------------	------------



# REPAIR INSTRUCTIONS SECOND STAGE DEMAND VALVE

3755 - Second stage

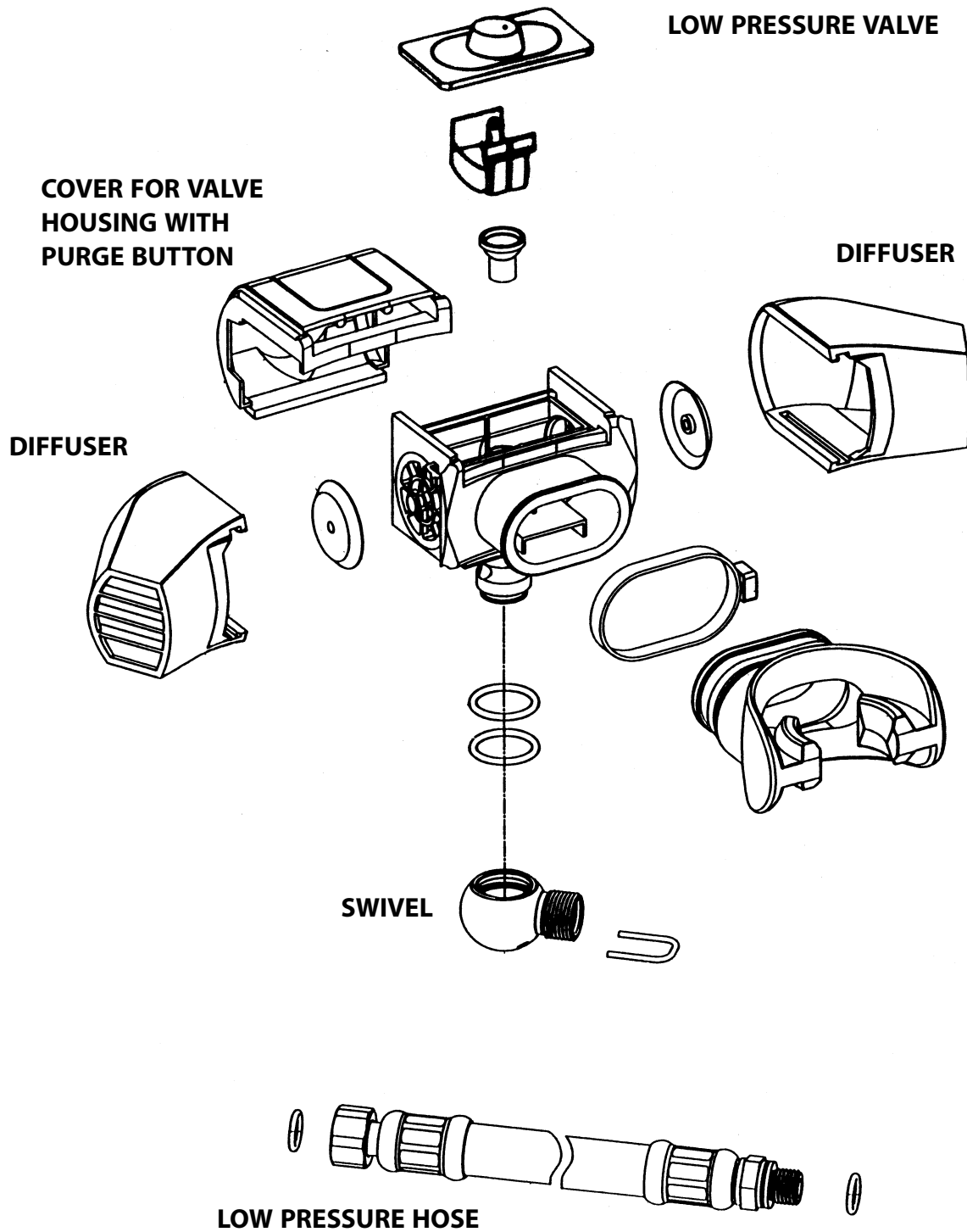

## SECOND STAGE 3755

### Removal:

1. Disconnect the low pressure hose from the second stage with a 15 mm open wrench. Remove the o-ring (14) with an o-ring remover. Remove the securing clip (13).
2. Remove the swivel (12).
3. Remove the o-rings (11) with an o-ring remover. Make sure that the sealing surfaces are not damaged.
4. Remove the diffusers (8). Press the catches and push out the diffuser.

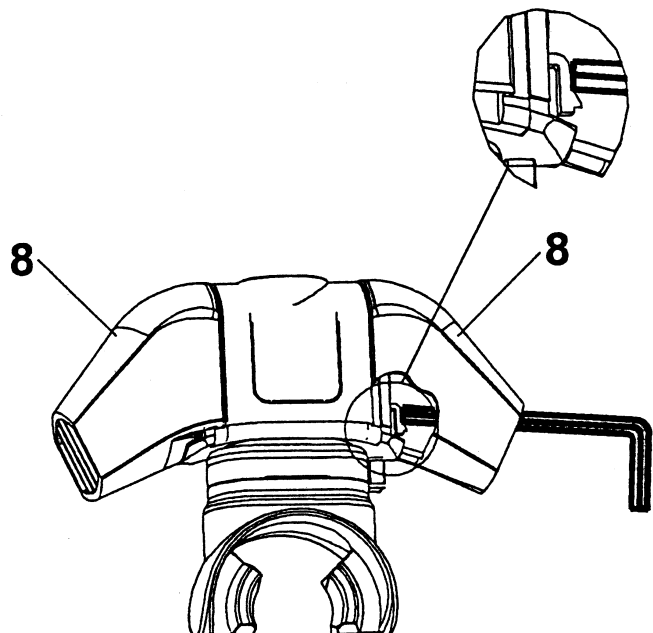
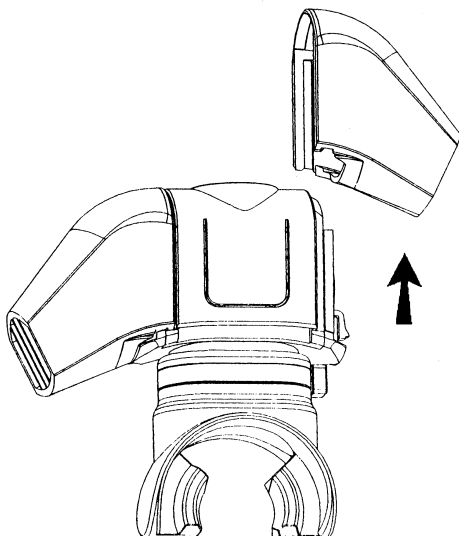
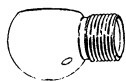
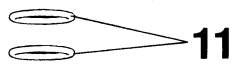
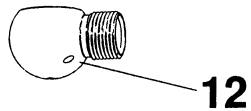
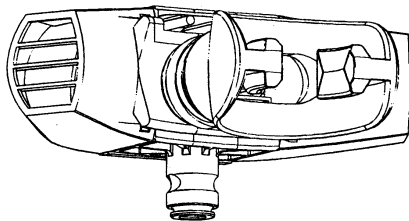
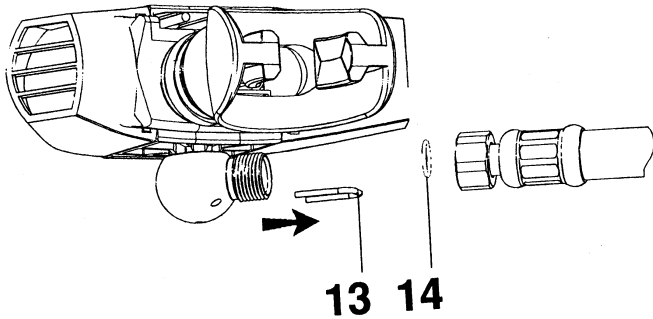

## SECOND STAGE 3755

### Removal:

1. Cut off the locking strap (9) with cutting pliers. Remove the mouthpiece (10).

2. Remove the cover (6)

3. Remove the diaphragm (1) with an o-ring remover. Make sure that the sealing surfaces are not damaged.

4. Remove the exhaust valves (7).

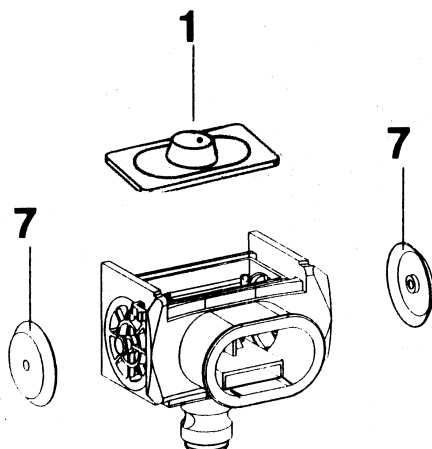
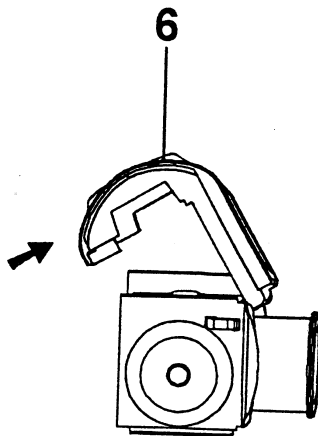
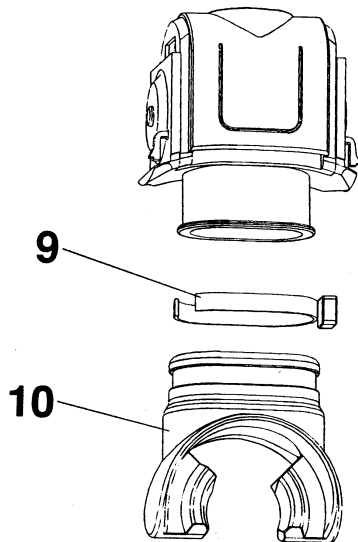

### Removal:

Remove the servo valve (2) with removal tool (no 3601) see fig. Be careful so that the holders do not break.

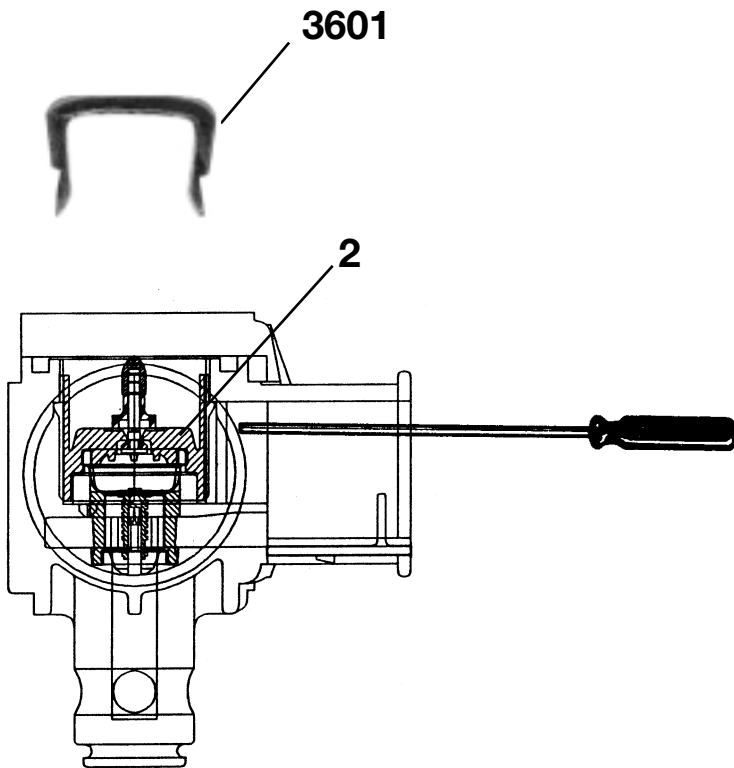

1. Press down the removal tool carefully so that the holders bend inwards and the servo valve "pops up".

2. Thereafter press up the servo valve with a screwdriver, see fig.

3. Remove the valve piston (3) from the servo valve.

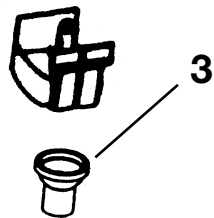

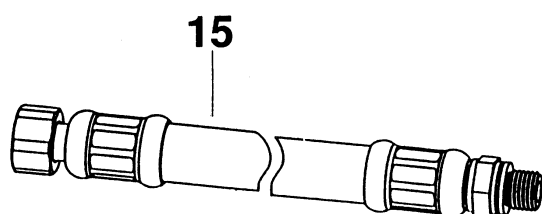
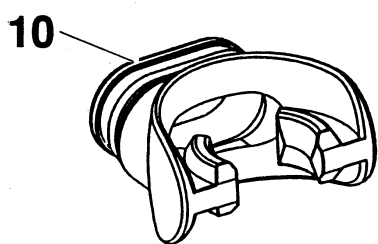
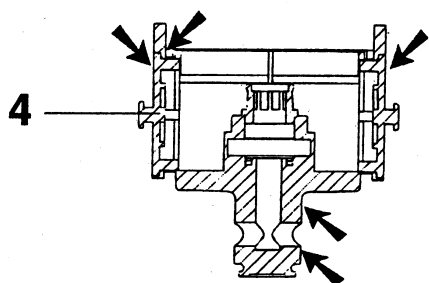
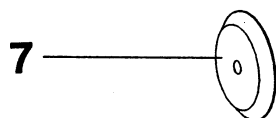
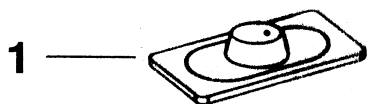

## SECOND STAGE VALVE 3755

**When servicing the regulator  
the following parts should be  
replaced:**  
(see chapter servicekit)

**Before assembly check  
the following:**

1. Diaphragm (1) and exhaust valves (7). Check the sealing surface to see if it is even and uncracked.
2. Valve housing (4). Make sure that the sealing surfaces are free from defects and that the track for the diaphragm is absolutely clean.
3. The mouth-piece (10). Make sure that there are no cracks.
4. Low pressure hose (15). Check to make sure that the sealing surface is undamaged, and that the rubber does not show any flaws.

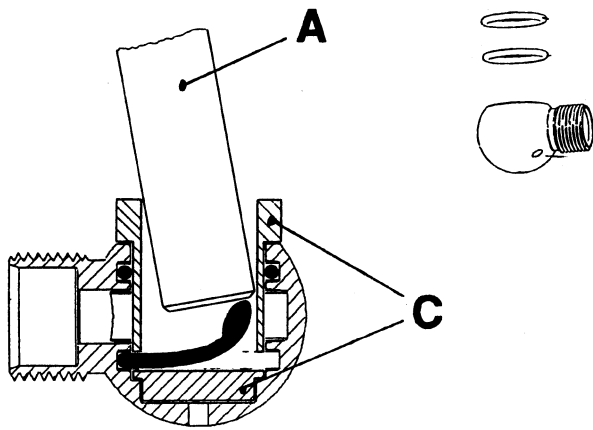

## SECOND STAGE 3755

### Assembly

Installing o-rings in the swivel connection.

Place the fixtures according to fig. 1. Install an o-ring in the fixture.

Press down the o-ring in the track of the swivel with tool B.

Remove the fixtures, press out the lower fixture with the o-ring remover through the hole in the bottom of the swivel.

Mount the upper o-ring in the track.

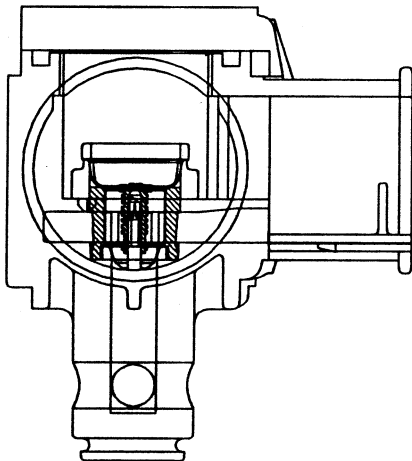
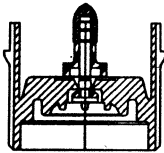

### Assembly of low pressure valve

1. Place the valve piston in the low pressure valve guide.
2. Mount the servo valve and press firmly (until you hear a click).

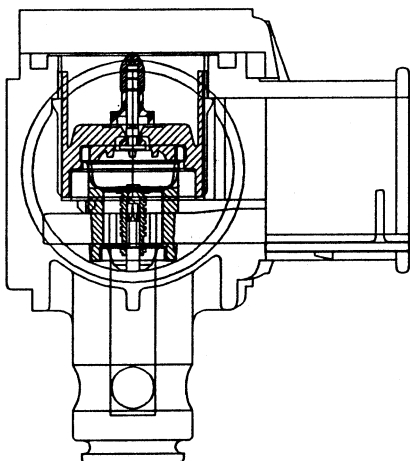

## SECOND STAGE 3755

### Assembly:

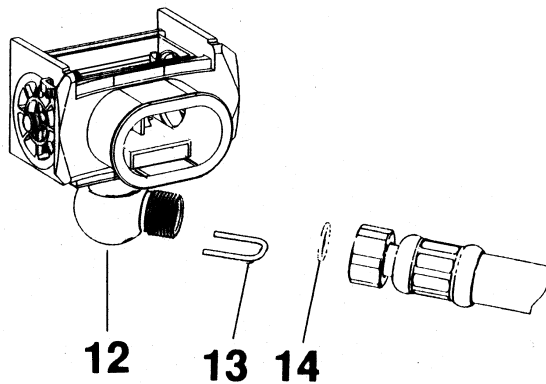
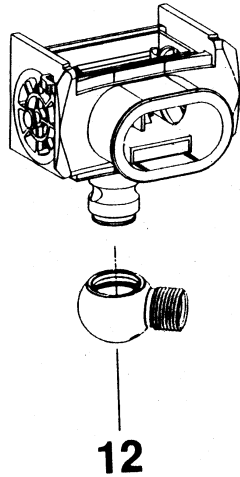

1. Lubricate the inside of the swivel (12) and press it on the second stage.
2. Press in the securing clip (13). Install the o-ring (14) on the low pressure hose. Lubricate the o-ring (14) and the thread at the swivel (12). Screw the low pressure hose on the swivel. Tighten with a 15 mm open wrench.
3. Test the low pressure valve for leaks according to chapter "Testing and adjustment of regulator Triton".

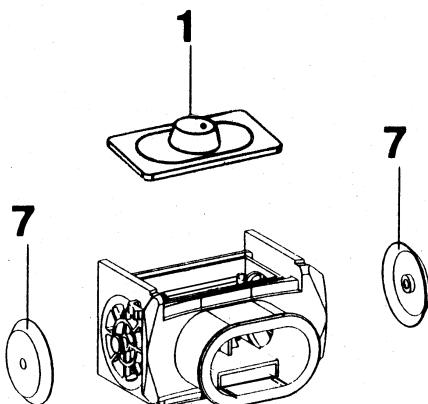

4. Install the exhaust valves (7) and the diaphragm (1). Press the edge of the diaphragm into the groove of the valve housing. Use an o-ring remover.

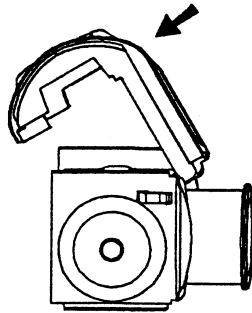

1. Install the cover (6). Put the lower part of the cover against the valve housing. Press it on.

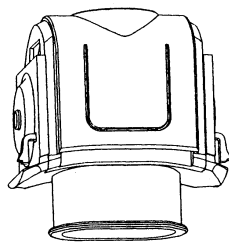

2. Install the mouth piece (10) and the locking strap (9). Tighten and cut off locking strap with plastic band pliers.

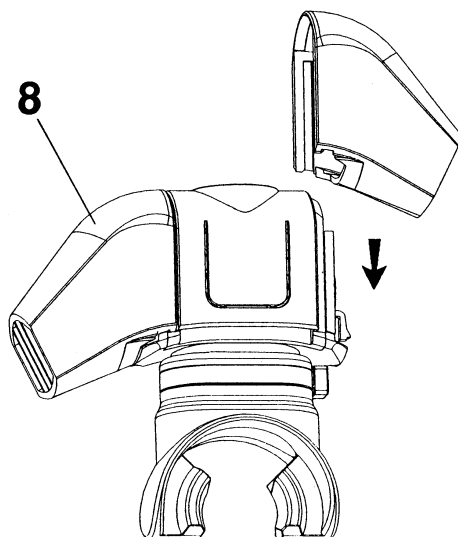
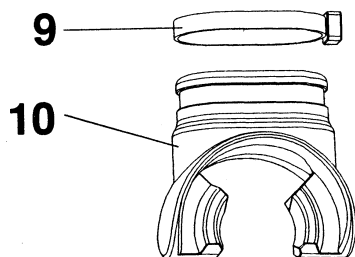

3. Install the diffusers (8). Make sure the catches are fastened.



# REPAIR INSTRUCTIONS FIRST STAGE REDUCING VALVE

3880 - First stage G 5/8"

3880-10 - First stage YOKE

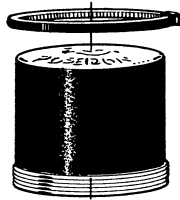

ANTI-FREEZE CAP

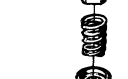
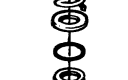
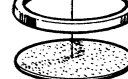
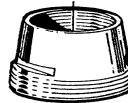
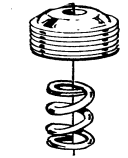

## DIFFERENT CONNECTIONS

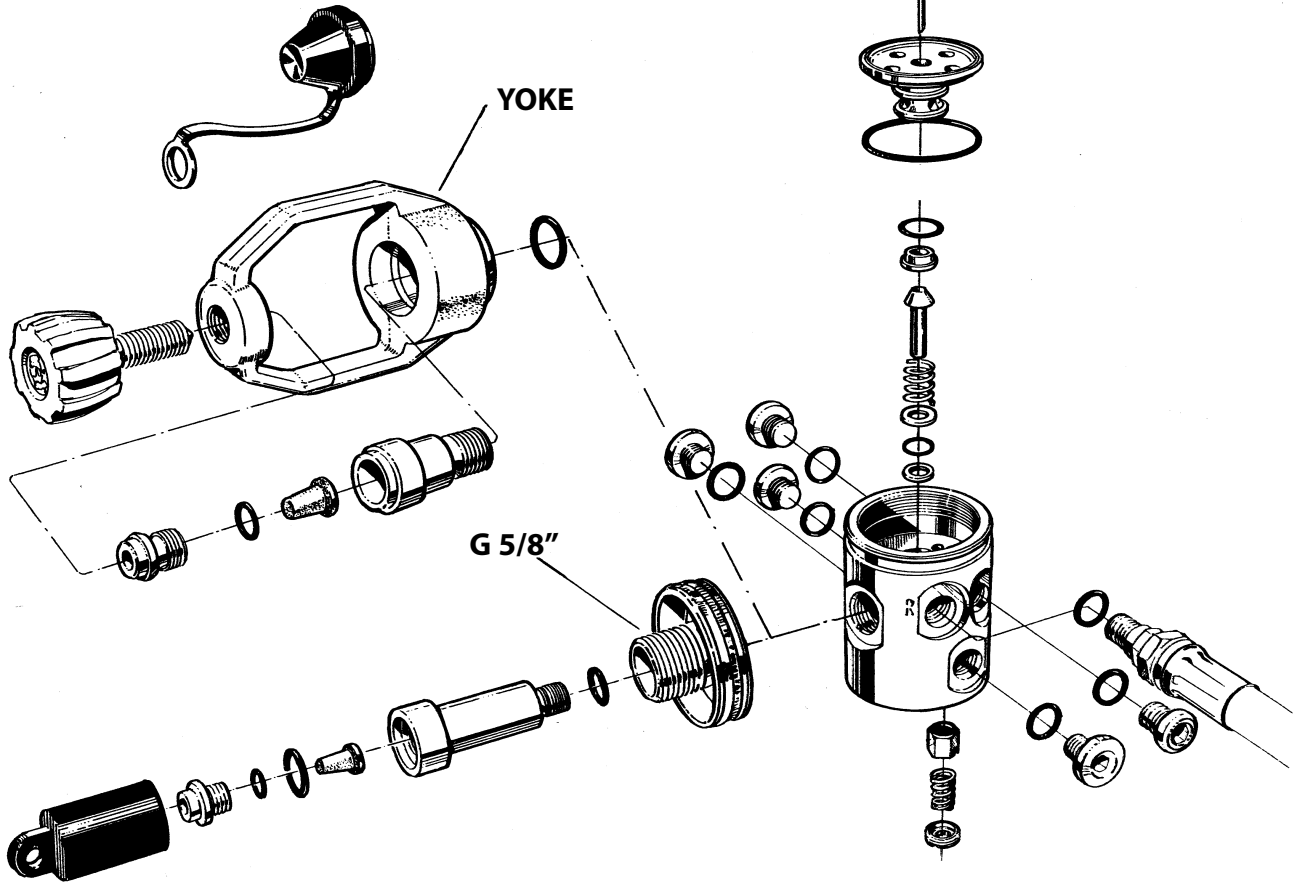

SAFETY VALVE

## FIRST STAGE VALVE 3880, 3880 10

### Secondary side:

1. Disconnect the low pressure hose from the first stage valve using a 13 mm open end wrench.
2. Remove the o-ring (30) from the low pressure hose with the o-ring remover.

### First stage valve with G 5/8":

3. Remove the locking screw (22) with a 6 mm Allen wrench. Remove the o-ring (24) and the cup-filter (25) with o-ring (23).

### First stage valve with Yoke:

3. Remove the knob (23) and the protective cap (21). Remove the locking screw (24) with a 6 mm Allen wrench. Remove the cup filter (26) and the o-ring (25).
4. Place the first stage valve with the secondary side facing upwards in the fixture.

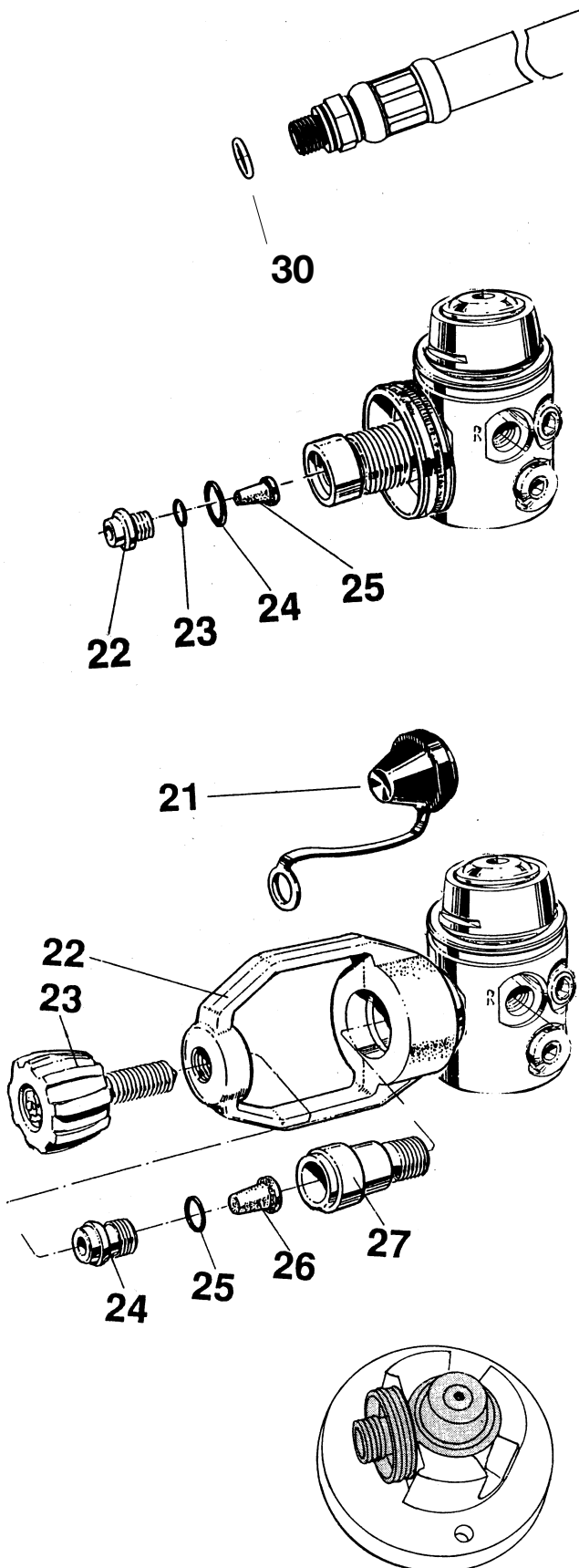

## FIRST STAGE VALVE 3880, 3880 10

### Removal:

1. Remove the pressure adjusting screw (1) with a 6 mm Allen wrench and remove the spring (2 and 3).
2. Remove the cover (4) using a 27 mm crowsfoot and the upper diaphragm center (5).

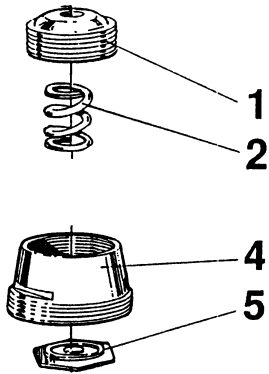

### First stage valve with G 5/8":

3. Remove the connection (26) and the wheel (28) with a 6 mm Allen wrench.
4. Remove the o-ring (27) with an o-ring remover. Make sure the sealing surfaces are not damaged.

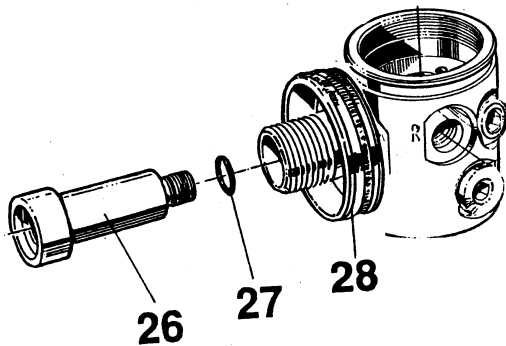

### First stage valve with Yoke:

3. Remove the connection (27) and the yoke (22) with a 6 mm Allen wrench.
4. Remove the o-ring (28) with an o-ring remover. Make sure the sealing surfaces are not damaged.

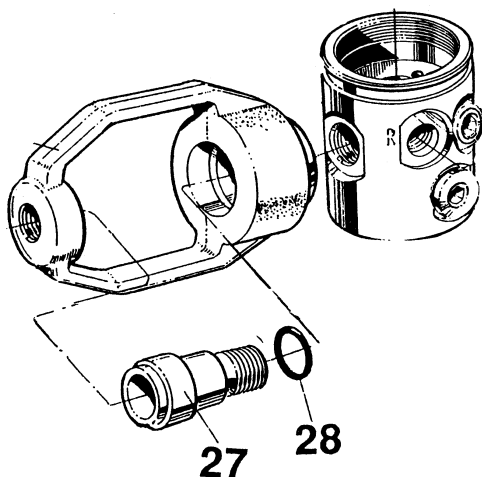

## FIRST STAGE VALVE 3880, 3880 10

### Removal:

1. Remove the valve centre, upper (6) and the diaphragm (7).
2. Remove the diaphragm centre, lower (8) and the valve needle (9).
3. Remove the valve centre, lower (10) and the o-ring (11) with an o-ring remover. Make sure the sealing surfaces are not damaged.
4. Remove the o-ring (12), only 3790, from the valve centre, lower (10) with an o-rings remover. Make sure the surfaces are not damaged.
5. Remove the valve seat (14) and the o-ring (13) with a adjusting tool no 2705.
6. Remove the valve piston (15) and the pressure spring (16).
7. Remove the washer, steel (17), the o-fing (18) and the washer, teflon (19) with an o-ring remover. Make sure the surfaces, are not damaged.

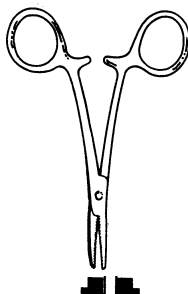
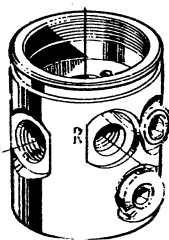
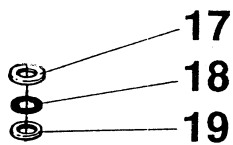
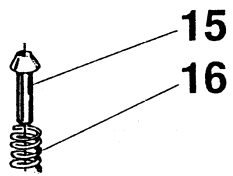
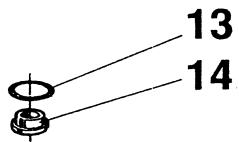
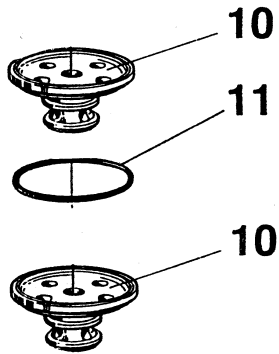

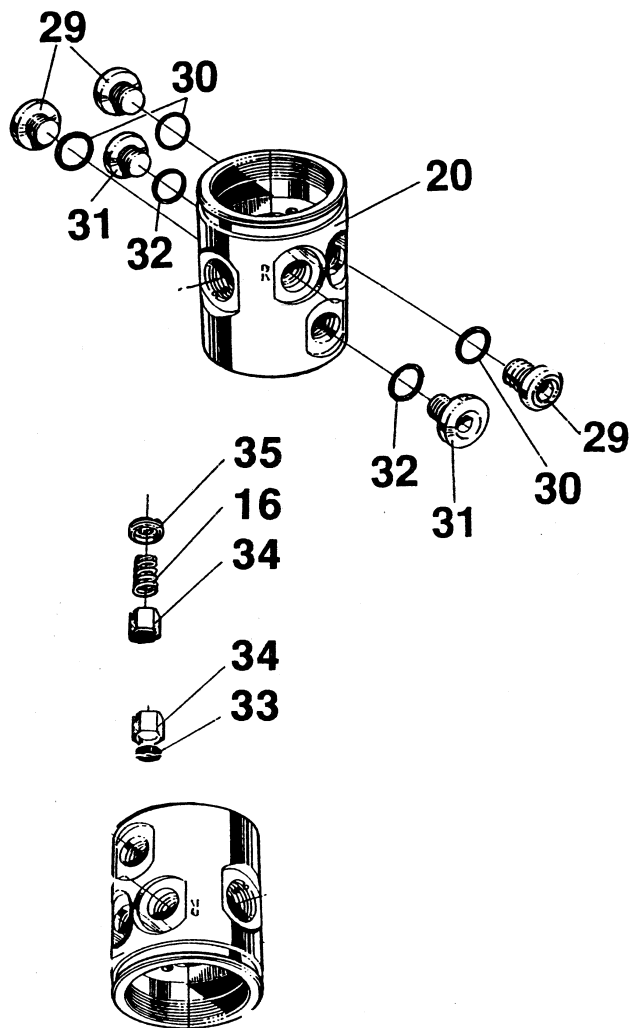

## FIRST STAGE VALVE 3880, 3880 10

### Removal:

1. Remove the blind screw (29 and 31) with a 5 mm Allen wrench. Remove the o-rings (30 and 32) with an o-ring remover. Make sure the sealing surfaces are not damaged.
2. Remove the locking screw (35) with a 4mm Allen wrench. Remove the pressure spring (16) and the valve piston (34).
3. Remove the valve sealing (33) from the valve piston (34) with an o-ring remover.

### Cleaning:

If corrosion or salt deposits occurs, place all metal parts in concentrated Hempodid\* or 15% Hydrochloric acid for about 10 minutes. Then rinse them thoroughly and blow dry with air. The synthetic parts in the second stage must not be treated with solvent. They shall be cleaned in freshwater only. \*Hempodid = Acid Liquid Detergent Containing phosphoric acid (5-10%) and bactericid for disinfectant cleaning.

## FIRST STAGE VALVE, 3880, 3880 10

**When servicing the regulator  
the following parts should be  
replaced:**  
(see chapter Servicekit)

1. All o-rings
2. Diaphragm
3. Cup filter
4. Valve seat
5. Washer
6. Valve sealing

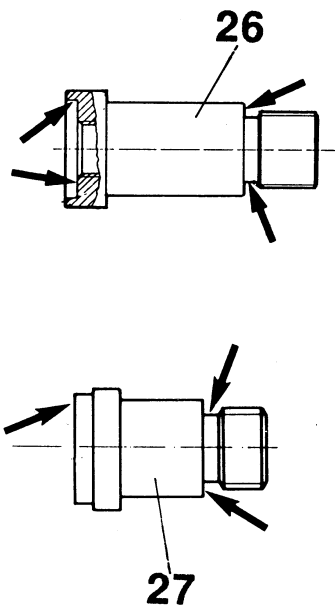
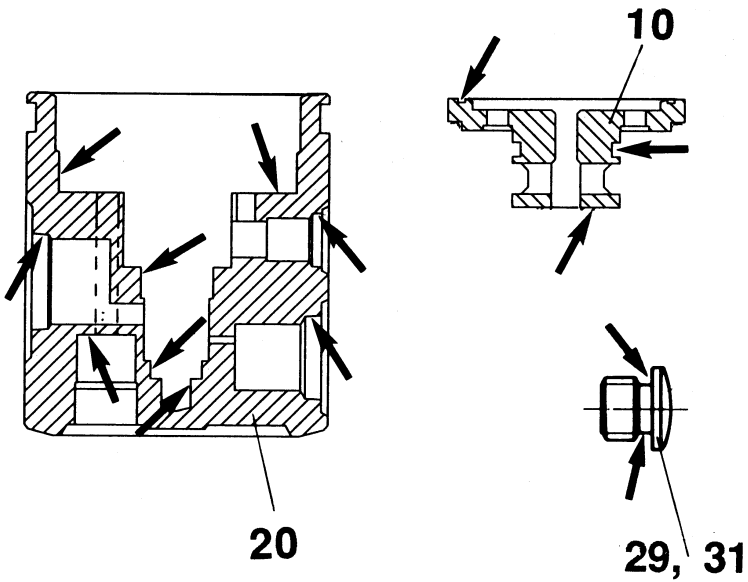

### Checking:

Check the following parts to make sure the sealing surfaces are undamaged. Also check that the threads are not damaged.

1. The blind screws (29 and 31)
2. The valve housing (20)
3. Valve centre (10)
4. The connections (26 or 27)

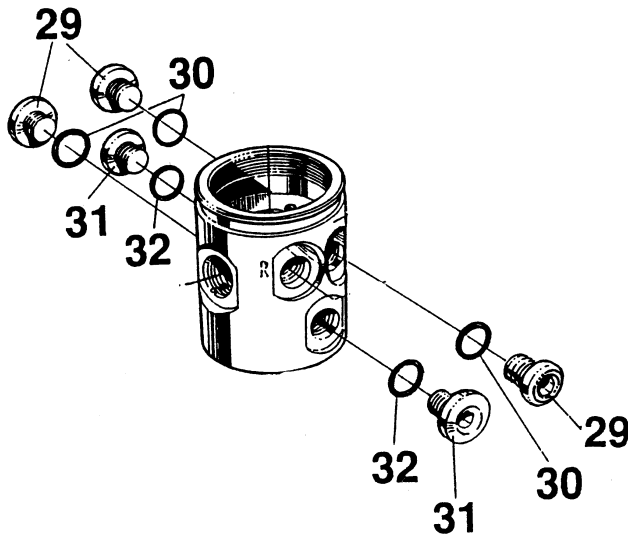

## FIRST STAGE VALVE 3880, 3880 10

### Assembly:

1. Install the o-rings(30 and 32) on the blind screws (29 and 31). Lubricate the outlets.
2. Screw the blind screws in the LP-HP outlets. Use a 5 mm hexagon spanner and tighten up by hand.

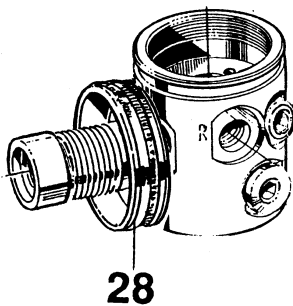
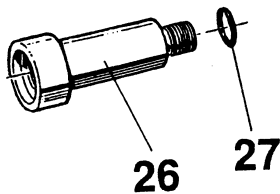

### First stage valve with G 5/8":

1. Install the o-ring (27) on the connection (26). Lubricate the o-ring and the thread.
2. Install the wheel (28) on the connection.
3. Screw the wheel connection assembly into the valve housing with a 6 mm Allen wrench.

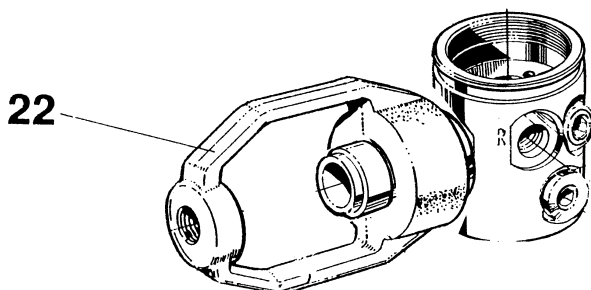
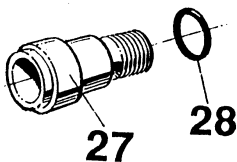

### First stage valve with Yoke:

1. Install the o-ring (28) on the connection (27). Lubricate the o-ring and the thread.
2. Install the yoke (22) on the connection.
3. Screw the yoke connection assembly into the valve housing with a 6 mm Allen wrench.

## FIRST STAGE VALVE 3880, 3880 10

### Assembly:

1. Lubricate the valve housing (20).

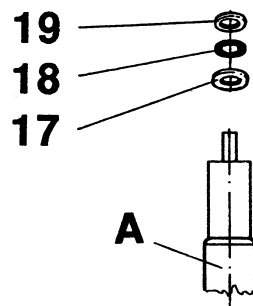
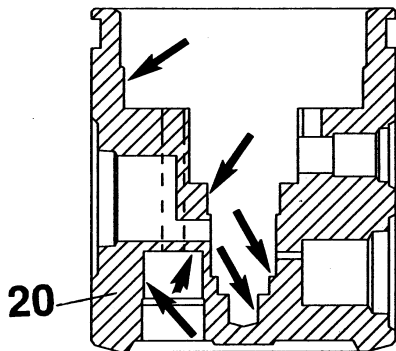

2. Place on the assembly drift A:

- washer, steel (17)
- O-ring (18)
- washer, teflon (19)

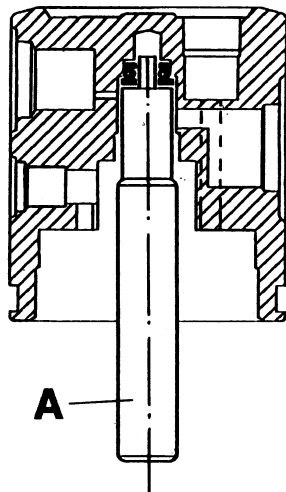

3. Install the valve housing.

Lubricate the washers  
and the o-ring.

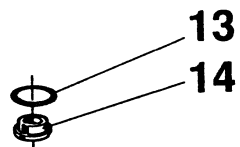

4. Install the o-ring (13) on the  
valve seat (14).



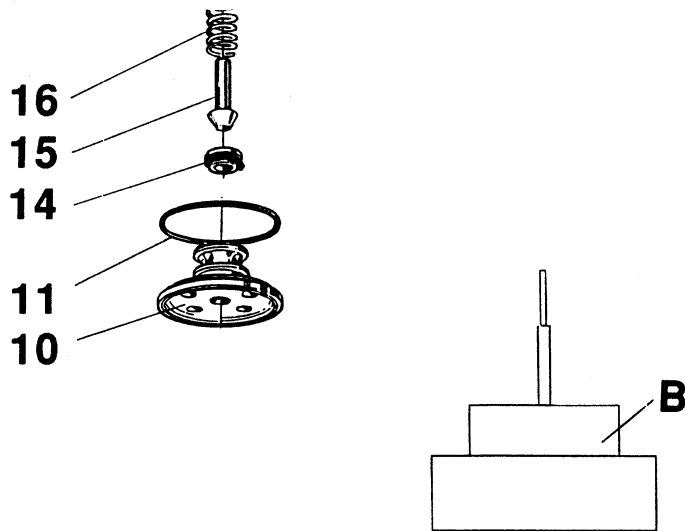

## FIRST STAGE VALVE 3880, 3880 10

### Assembly:

1. Place on the assembly fixture B:
  - valve centre, lower (10)
  - o-ring (11), lubricate
  - valve seat (14) with o-ring downwards
  - valve piston (15), lubricate, and pressure spring (16) on valve piston.

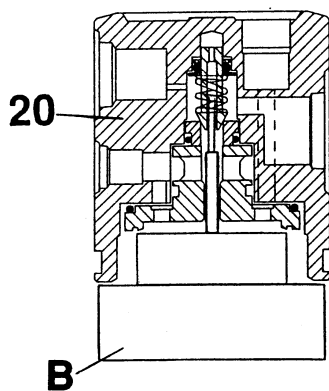

2. Install the valve housing (20).

3. Turn the valve housing (20) with the secondary side upwards.

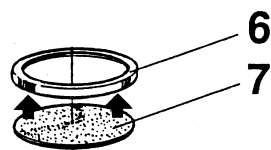

4. Install the valve needle (9).

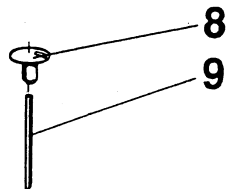

5. Install the lower diaphragm centre (8).

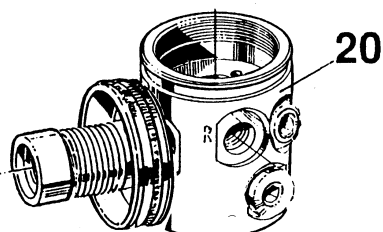

6. Install the diaphragm (7) in the valve centre, upper, convex part up (6). Install the valve housing (20).

## FIRST STAGE VALVE 3880, 3880 10

### Assembly:

1. Install the diaphragm centre, upper (5) in the valve housing (20).
2. Grease the thread on the cover (4) and tighten up by hand.
3. Check to make sure that the parts are correctly installed by pressing at the valve centre. It should move approximately 2 mm (1/16").
4. Lubricate both ends of the spring (2 and 3) and install. Lubricate the thread on pressure adjusting screw (1), and tighten 7 turns with a 6 mm Allen wrench.
5. Install the valve sealing (33) on the valve piston (34).
6. Install the valve piston (34) and the pressure spring (16). Install the locking screw (35) with a 4 mm Allen wrench. Tighten up by hand.

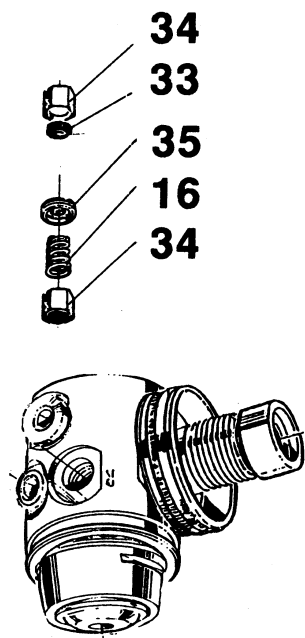
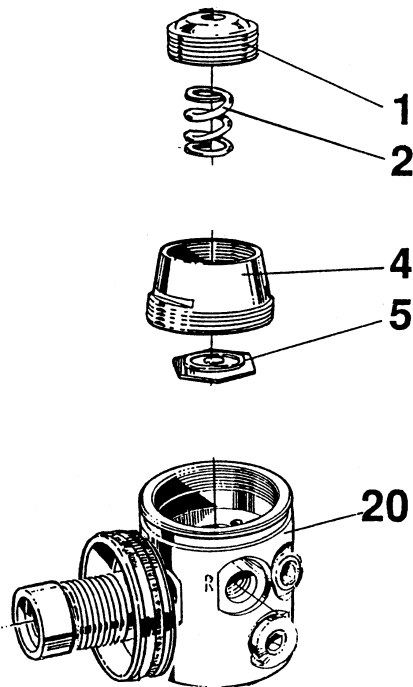

## FIRST STAGE VALVE 3880, 3880 10

### Assembly:

1. Place the valve housing (20) in a fixture.
2. Tighten the cover for valve housing with a torque wrench (30 Nm) and an open ended insert tool 27 mm.
3. Tighten the connection with a torque wrench (30 Nm) and holder insert tool/ bits.  
**IMPORTANT!** Use bits nr 3119 (L = 40 mm).

### First stage valve with G5/8":

4. Put o-ring (23) on the cup type filter (25). Install them and the o-ring (24) and the locking screw (22) in the connection (26). Tighten with a Allen wrench 6 mm.

### First stage valve with Yoke:

4. Put o-ring (25) on the cup type filter (26). Install them and the locking screw (24) in the connection (27). Tighten with a Wrench 6 mm. Put the protective cap (21) on the knob (23). Lubricate and screw in the knob.
5. Install o-ring (30) on the low pressure hose. Lubricate the o-ring and the thread. Tighten the hose with a 13 mm open wrench.

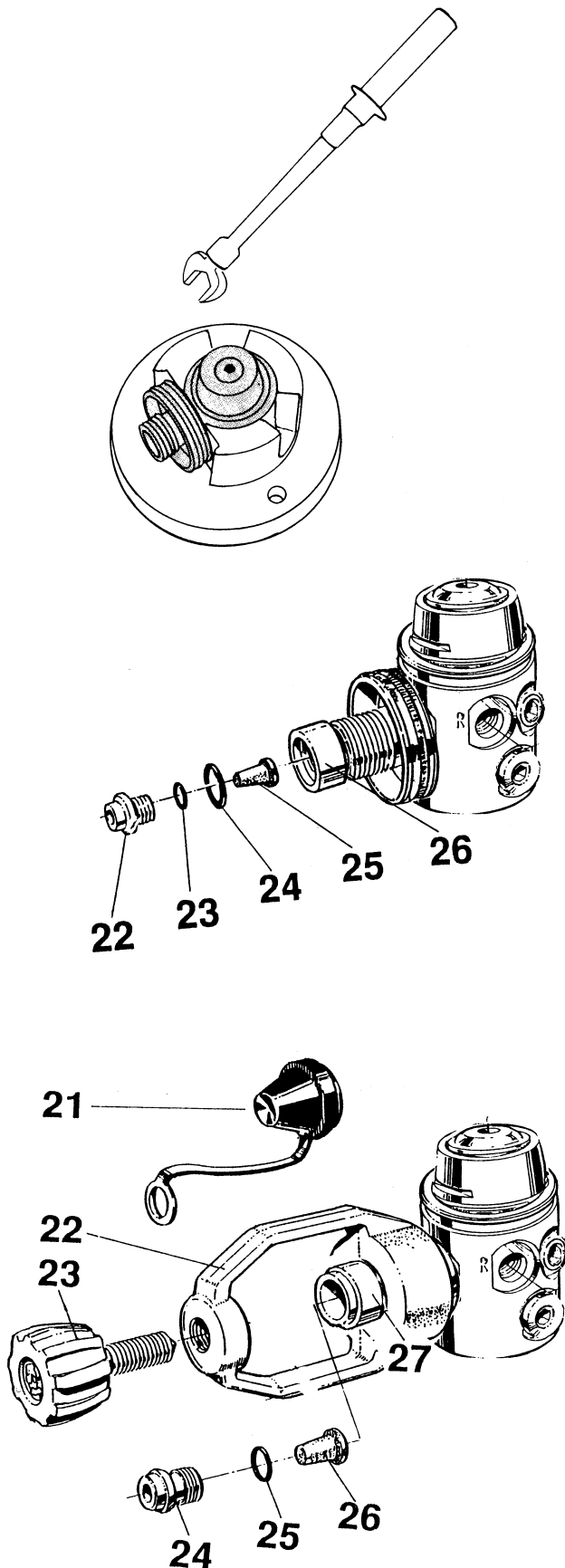

# TESTING AND ADJUSTMENT OF REGULATOR

## TRITON 2000 Art. No. 3750

### First stage valve:

1. Connect the regulator to the test box.
2. Connect the LP gauge hose to one of the low pressure outlets.
3. Open the LP valve (= 20 bar),.
4. Set the secondary pressure at 10 bar, and intermittently purge the second stage by means of the button. NOTE that the second stage valve must be fully tight during this test. When the pressure gauge needle stops at the preset pressure, a maximum rise in pressure of 1 bar is acceptable. If the needle continues to move to a higher pressure reading there is a fault in the seal between the valve seat and the piston or the O-ring.
5. Close the LP valve, and open the HP valve (=200/300bar). Purge intermittently with the purge button, check the tightness, and adjust the pressure to 8,5-9 bar.

### Second stage valve: Tightness test of the low pressure valve and the servo valve.

1. Push the servovalve on the low pressure valve carefully, and purge a few times. Immerse the valve in a water tank and make sure the valve is absolutely air tight.

### Checking and adjustment of the inhalation resistance:

1. Connect the oval connecting pipe of the inhalation resistance gauge to the mouth-piece on the regulator.
2. Test-breath. Check the reading of the gauge needle, which should rise to 38-44 mmvp when the valve is opening.
3. Adjustment:  
Remove the cover and the diaphragm. Hold the diaphragm center on the center part and push an Allen wrench No. 8510 (1,27 mm) in the adjustment screw.  
If the resistance is too low, turn the screw anticlockwise.  
If the resistance is too high, turn the screw clockwise.
4. Install the diaphragm with the adjustment screw to the right position and the cover. Test again from pos. 1.

### Checking the purge button:

1. Press the purge button. The second stage valve should now provide a generous supply of air.
2. Cover the mouth-piece and press the purge button. The second stage valve should now supply a reduced air flow.

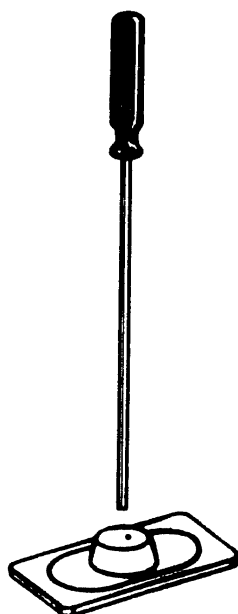

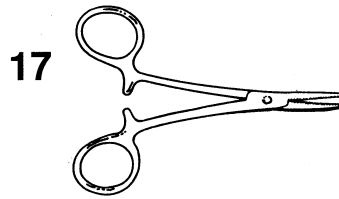
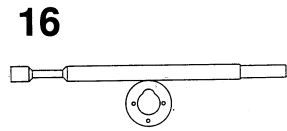
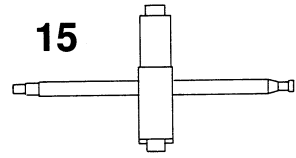
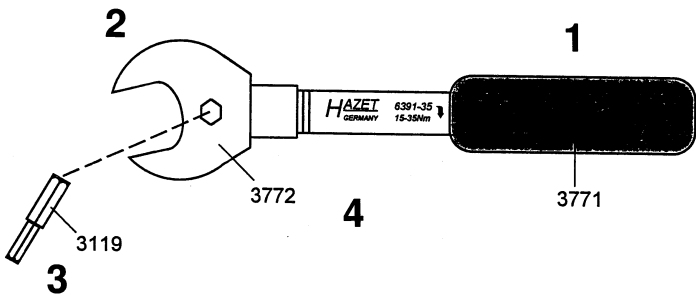

21

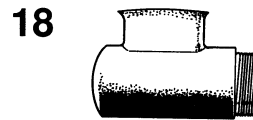
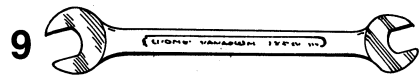

18

22

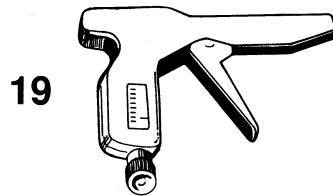

23

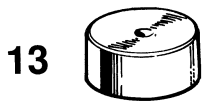
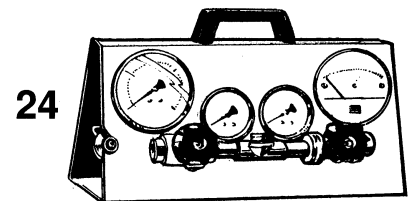
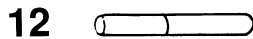

19

24

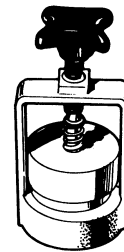

25



27

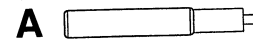

A

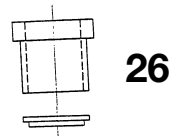

26

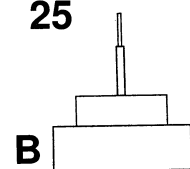

B

## SERVICE TOOL

1	3771	Torque wrench 30 Nm
2	3772	Open ended insert tool 27 mm with holder inset tool
3	3119	Bits 6 mm, length 40 mm
4	3773	Torque wrench set. Inkl. 3771, 3772, 3119
5	2883	Bits 6 mm, length 30 mm (For old type of yoke)
6	3774	Bits holder for Yoke
	8510	Allen wrench 1,27 mm
7	2706	Allen wrench 1,5 mm
	3761	Allen wrench 4 mm
8*	2714	Allen wrench 3 mm
	1246	Allen wrench 5 mm
	2275	Allen wrench 6 mm
9*	1354	Open end wrench I - 13 mm
	1388	Open end wrench 14 - 15 mm
	1312	Open end wrench 16 - 17 mm
10*	2893	Screw driver 3,5 mm
	2885	Screw driver 8,5 mm
11	2297	O-rings remover
12	2299	Drift for low pressure valve
13	3138	Holder for 2299
14	1304	Awl
15	3605	Combination tool no 1
16	3606	Combination tool no 2
	3875	Tool No. 3605 and 3606 in a box
17	2705	Adjusting tool
18	2894	Test fixture for low pressure valve
19	2150	Plastic band pliers
20	2112	Assembly tool
21	3397-10	Fixture for first stages
22	2587	Grease silicone 10 g
	8507	Grease Gleitmo 594 10 g
23	3139	Oil silicon 20 g
24	3460	Regulator test
25	3879	Toolkit:
	3717	Assembly drift A
	3757	Assembly fixture B
26	3758	Assembly fixture
27	3601	Dismounting tool for Triton

### \*Accessories

3873	Toolkit for Triton 2nd Stage:
8510	Allen wrench 1,27 mm
3601	Dismounting tool
3758	Assembly fixture

1133 Second stage Cyklon 300, yellow/black  
3354 Second stage Cyklon 5000 (Diveair), black  
3536 Second stage Octopus, yellow

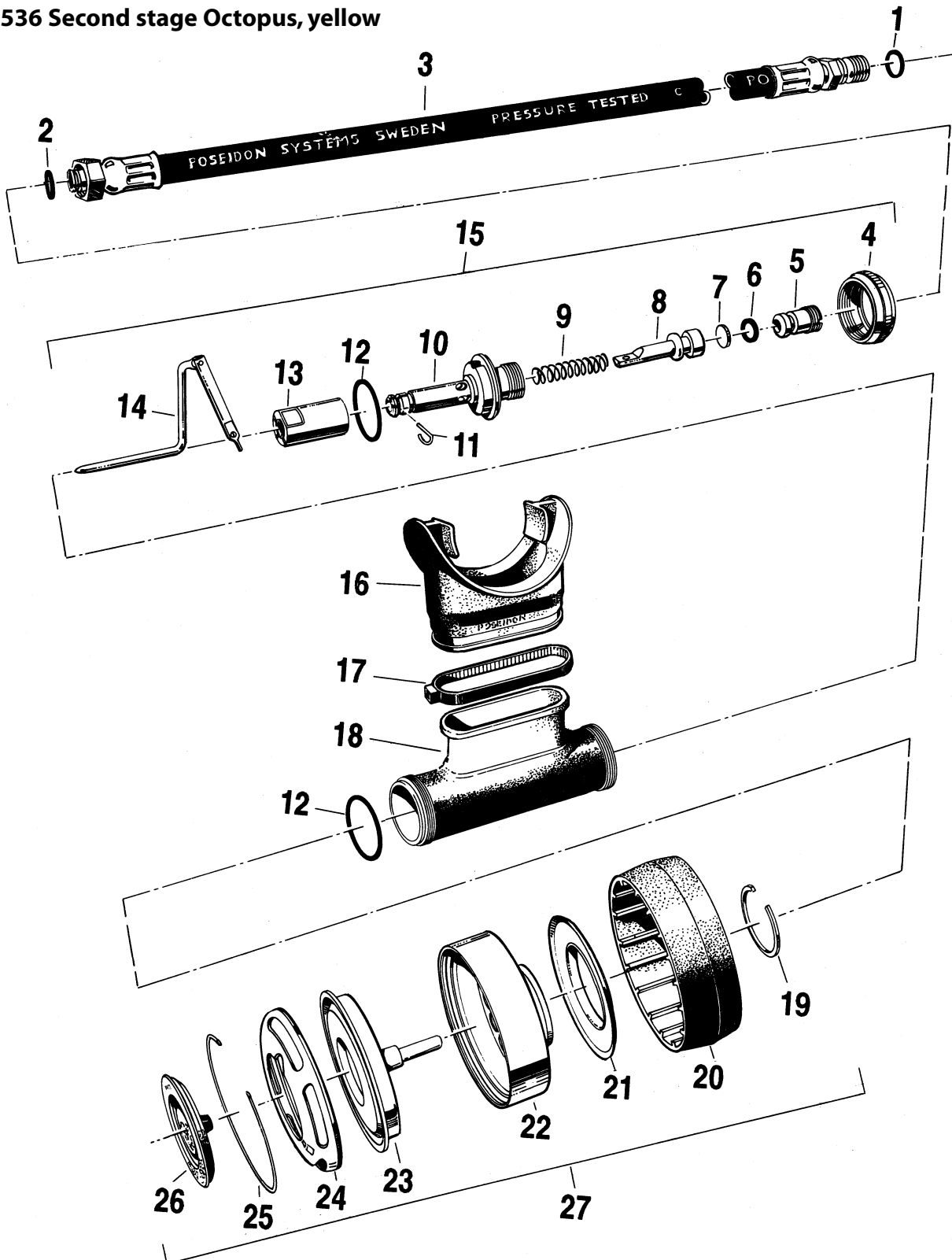

**1133 Second stage Cyklon 300, yellow/black**  
**3354 Second stage Cyklon 5000 (Diveair), black**  
**3536 Second stage Octopus, yellow**

<b>Pos.</b>	<b>No.</b>	
1	2782	O-ring
2	1156	O-ring
3	2946	Low pressure hose 70 cm UNF 3/8"
	2947	Low pressure hose 90 cm UNF 3/8"
4	1166	Connecting ring
5	1165	Valve seat
6	1164	O-ring
7	1162	Rubber plate
8	2429	Valve piston
9	1157	Pressure spring
10	1163	Valve housing
11	1155	Lever pin
12	1145	O-ring (2 pcs)
13	2307	Ejector sleeve
14	1151	Operating device
15	1150	Low pressure valve (incl. 5-14)
16	3202	Mouth piece
17	1167	Locking strap
18	3200 10	Mouth piece tube black
	3200 30	Mouth piece tube yellow
19	1144	Locking ring
20	1999 10	Cover for exhalation diaphragm, black
	1999 30	Cover for exhalation diaphragm, yellow
21	2579	Exhalation diaphragm
22	1141	Diaphragm, housing
23	2577	Inhalation diaphragm
24	2001	Cover for inhalation diaphragm
25	1140	Locking ring
26	2004	Purge button
27	2000 10	Diaphragm housing incl. 19-26, black
	2000 30	Diaphragm housing incl. 19-26, yellow



2305 First stage, Cyklon 300

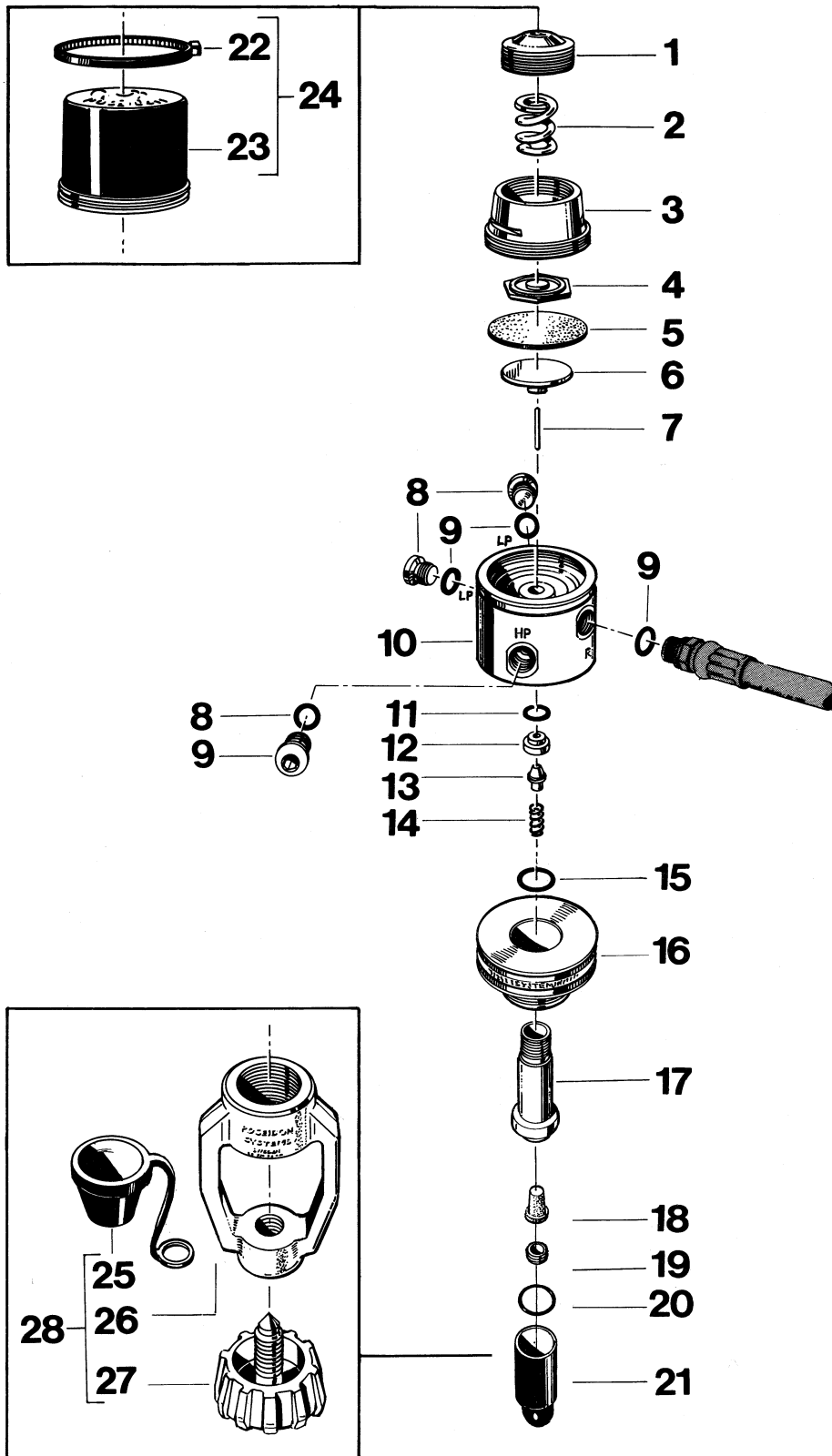

## 2305 First stage, Cyklon 300

Pos.	No.	
1	3417	Pressure adjusting screw
2	2802	Secondary spring
3	2814	Cover for valve housing
4	2815	Diaphragm centre, upper
5	1189	Diaphragm
6	1176	Diaphragm centre, lower
7	2182	Valve needle
8	2807	Blind screw
9	1013	Gasket
10	2306	Valve housing
11	1156	O-ring
12	2302	Valve seat
13	1179	Valve piston
14	1180	Pressure spring
15	1233	O-ring
16	2222	Wheel G5/8
17	2175	Connection
18	1377	Cup type filter
19	1183	Locking screw
20	1007	O-ring
21	2402	Protective cap
22*	2778	Locking strap
23*	1287	Anti-freeze cap
24*	1286	Anti-freeze cap with locking strap
25*	2277	Protective cap
26*	2921	Yoke
27*	2922	Knob
28*	2920	Yoke complete incl. 26-28

\*Accessories

2801 First stage, Wheel G 5/8"  
 2808 First stage, Yoke  
 Maximum

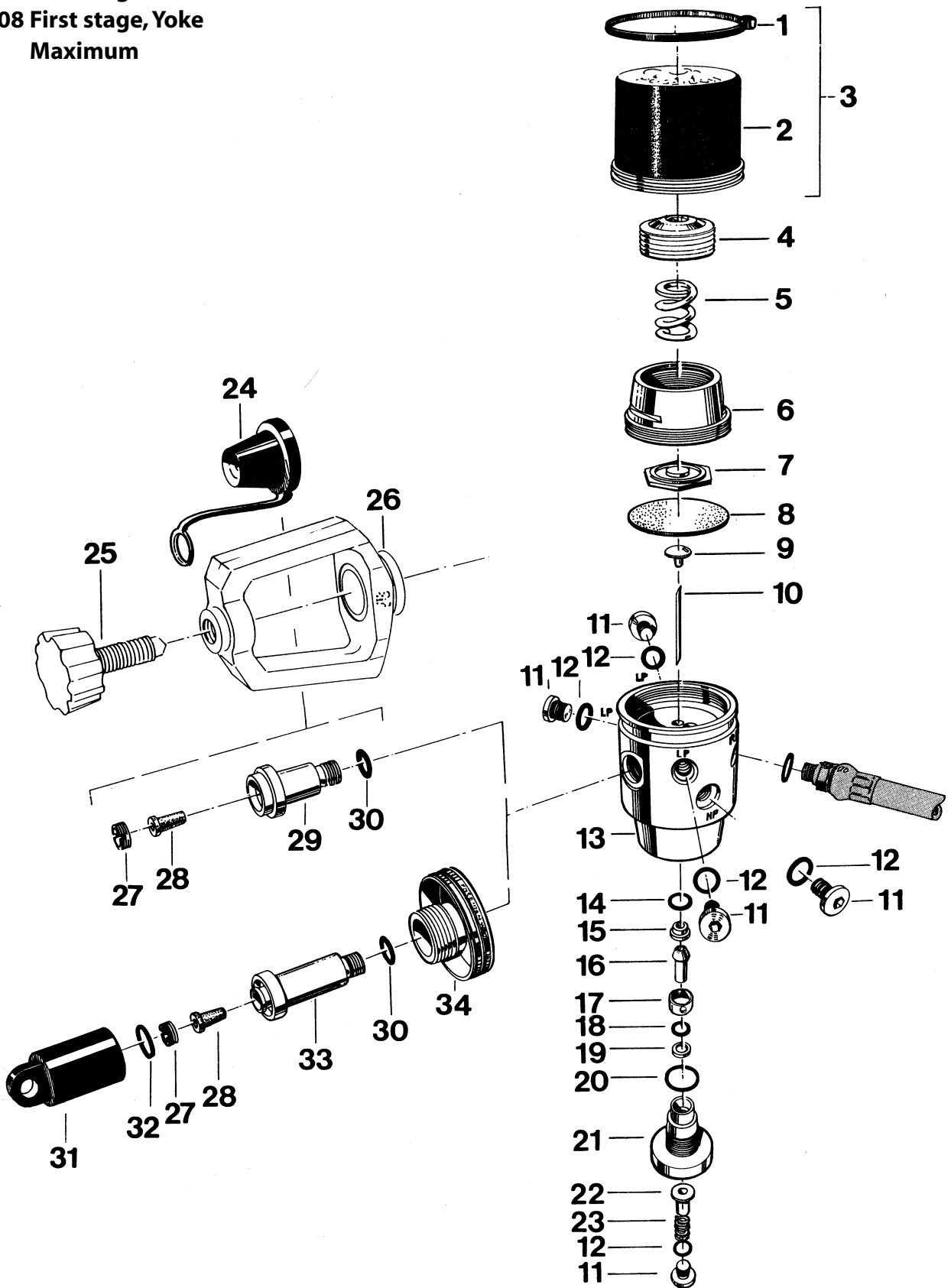

**2801 First stage, Wheel G 5/8"****2808 First stage, Yoke****Maximum**

<b>Pos.</b>	<b>No.</b>	<b>Description</b>
1*	2778	Plastic band (extra)
2*	1287	Anti-freeze cap (extra)
3*	1286	Anti-freeze cap incl. plastic band (extra)
4	3417	Pressure adjusting screw
5	2802	Secondary spring
6	2814	Cover for reducing valve housing
7	3419	Diaphragm centre, upper
8	1189	Diaphragm
9	2816	Diaphragm centre, lower
10	2817	Valve needle
11	2807	Blind screw
12	1562	O-ring
13	2819	Valve housing
14	1156	O-ring
15	2803	Valve seat
16	2820	Valve piston
17	2821	Spacing sleeve
18	1368	O-ring
19	2822	Washer
20	2809	O-ring
21	2823	Balanced housing
22	3388	Spring piston
23	3387	Pressure spring
24	2277	Protective cap
25	1227	Knob
26	1841	Yoke
27	1183	Locking screw
28	1377	Cup filter
29	2825	Connection Yoke
30	1839	O-ring
31	2402	Protective cap
32	1007	O-ring
33	2830	Connection G5/8"
34	2828	Wheel G5/8"

\*Accessories

2961 Second stage Jetstream, USA=Odin, Black  
2941 Second stage Jetstream, USA=Odin, Yellow/Black  
3546 Second stage Octopus, Yellow

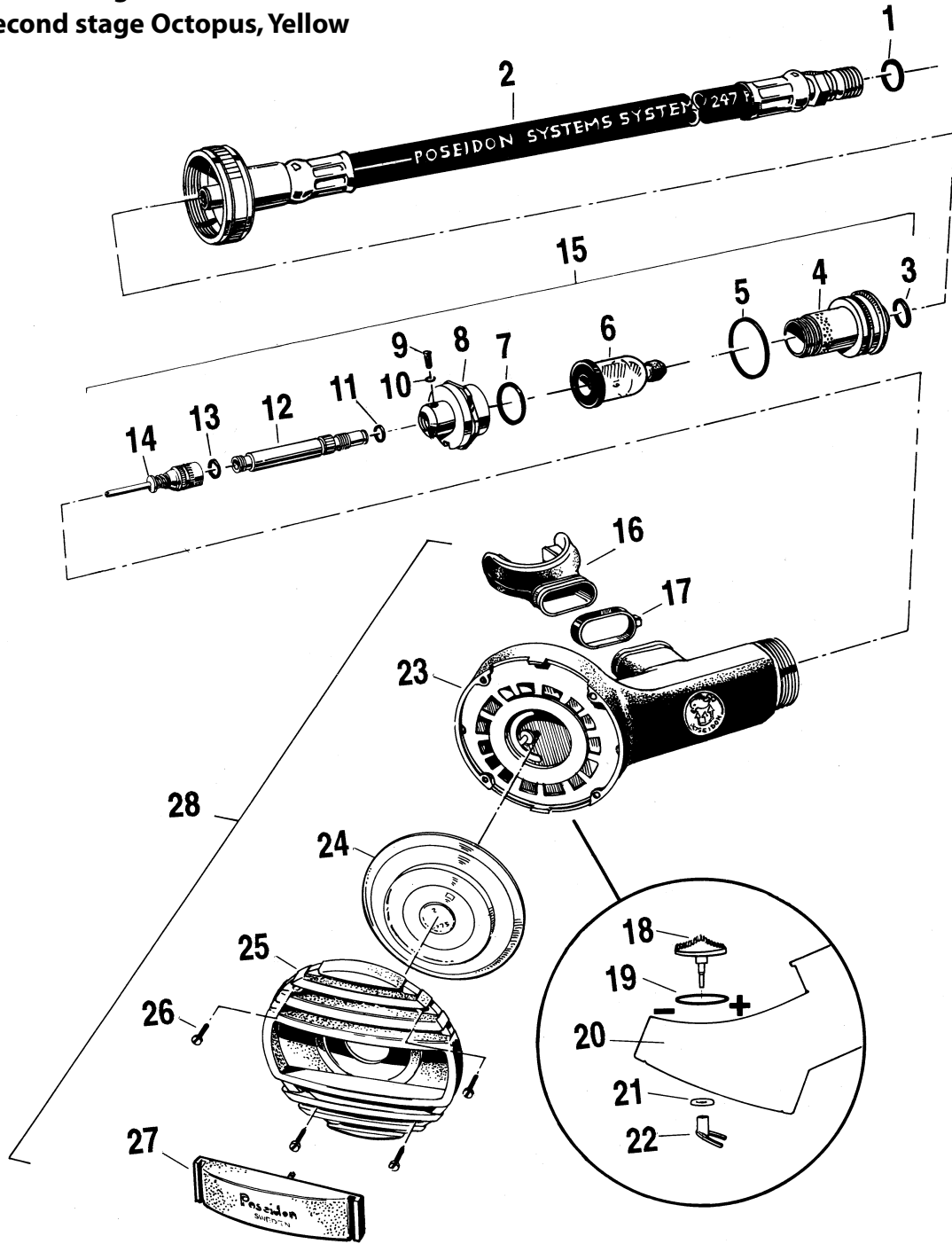

**2961 Second stage Jetstream,USA=Odin, Black****2941 Second stage Jetstream,USA=Odin, Yellow/Black****3546 Second stage Octopus, Yellow**

<b>Pos.</b>	<b>No.</b>	
1	2782	O-ring
2	2943	Low pressure hose with safety valve 70 cm UNF 3/8"
	2944	Low pressure hose with safety valve 90 cm UNF 3/8"
3	2856	O-ring
4	2857	Low pressure valve housing
5	1145	O-ring
6	3440	Valve insert
7	1233	O-ring
8	2974	Valve housing nut
9	2875	Stop screw
10	2787	Rubber plate
11	2876	O-ring
12	2839	Valve tube
13	1896	O-ring
14	2786	Servo valve complete
15	3088	Low pressure valve incl. 3-15
16	3202	Mouth piece
17	1167	Locking strap
18	2711	Switch
19	1851	O-ring
20	3121	Housing (cannot be bought separately)
21	2794	Lock washer
22	2712	Diaphragm cam
23	3122	Housing, second stage incl. 18-22,black
	3132	Housing, second stage incl. 18-22, yellow
24	2578	Diaphragm
25	2707	Cover for second stage, black
	2989	Cover for second stage, yellow
26	2851	Screw (4 pcs)
27	2853	Purge button
28	3124	Housing complete incl. 16-27, black
	3104	Housing complete incl. 16-27, yellow
	3134	Housing complete incl. 16-27, yellow/black

2962 First stage, Jetstream (USA = ODIN)  
 2962-10 First stage, Jetstream YOKE  
 3257 First stage, Diveair (USA = Cyklon 5000)  
 3257-10 First stage, Cyklon 5000 (Diveair) YOKE

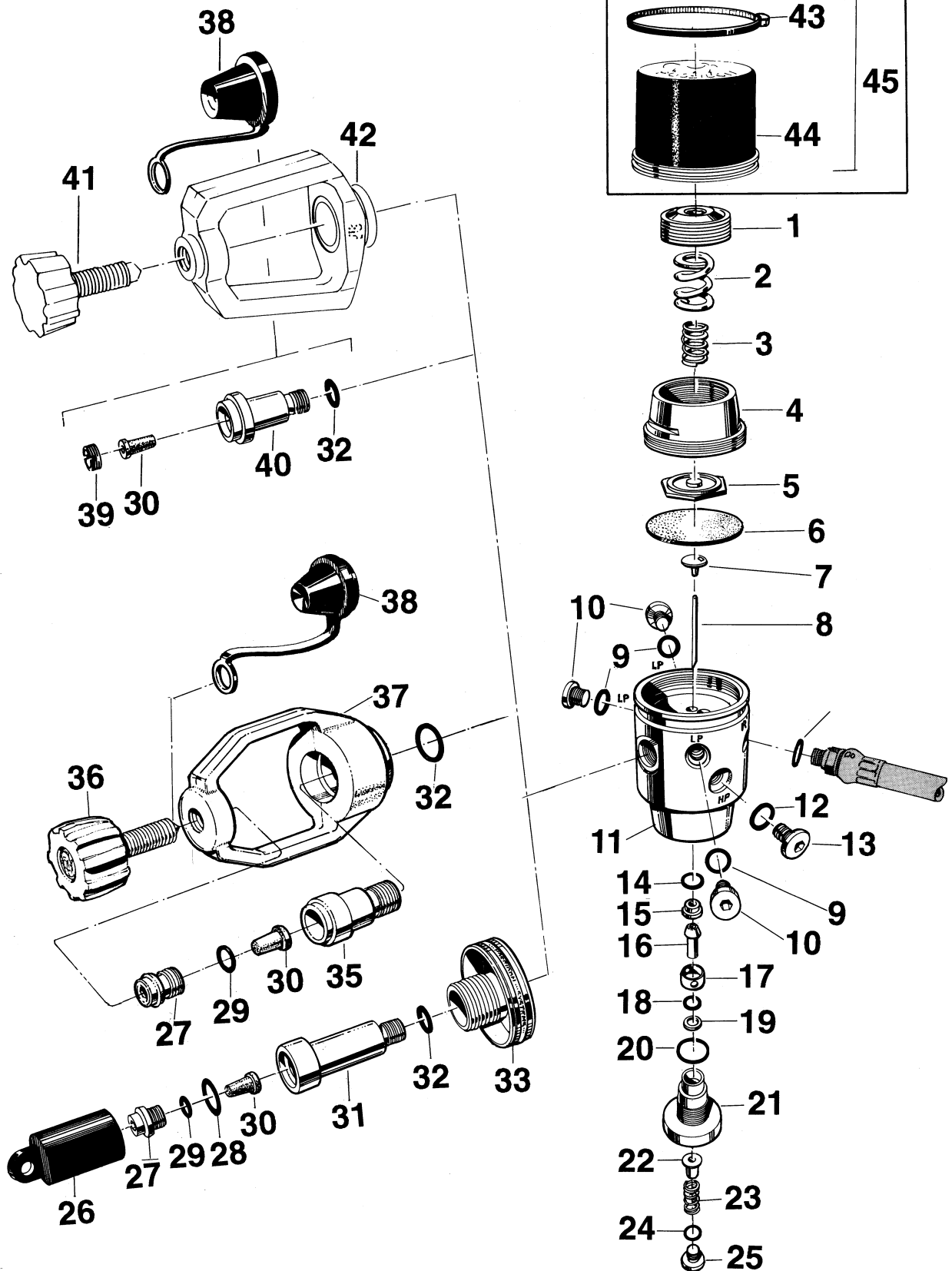

**2962 First stage, Jetstream (USA = ODIN)****2962-10 First stage, Jetstream YOKE****3257 First stage, Diveair (USA = Cyklon 5000)****3257-10 First stage, Cyklon 5000 (Diveair) YOKE**

<b>Pos.</b>	<b>No.</b>		<b>Pos.</b>	<b>No.</b>	
1	3417	Pressure adjusting screw	36	2922	Knob
2	2802	Pressure spring, outer	37	3473	Yoke
3	3418	Pressure spring, inner	38	2277	Protective cap
4	2814	Cover for valve housing	39	1183	Locking screw
5	3419	Diaphragm centre, upper	40	2825	Connection
6	1189	Diaphragm	41	1227	Knob
7	2816	Diaphragm centre, lower	42	1841	Yoke
8	2817	Valve needle	43*	2778	Locking strap
9	2782	O-ring (4 pcs)	44*	1287	Anti-freeze cap
10	2679	Blind screw UNF 3/8"(3 pcs)	45*	1286	Anti-freeze cup with locking strap
11	2678	Valve housing, Jetstream			
	3258	Valve housing, Cyklon 5000			
12	2918	O-ring			
13	2680	Blind screw UNF 7/16"			*Accessories
14	1156	O-ring			
15	2803	Valve seat			
16	2820	Valve piston			
17	2821	Spacing sleeve			
18	1368	O-ring			
19	2822	Washer			
20	2809	O-ring			
21	2823	Balanced housing			
22	3388	Spring guidance			
23	3387	Pressure spring			
24	1562	O-ring			
25	2807	Blind screw G1/8"			
26	2402	Protective cap			
27	3096	Locking screw			
28	1007	O-ring			
29	2656	O-ring			
30	1377	Cup type filter			
31	2827	Connection			
32	1839	O-ring			
33	2828	Wheel G5/8"			
34	2966	Connection incl. 27-33			
35	3472	Connection			



3070 First stage, Cyklon 300 and Oceanair (USA=Thor)

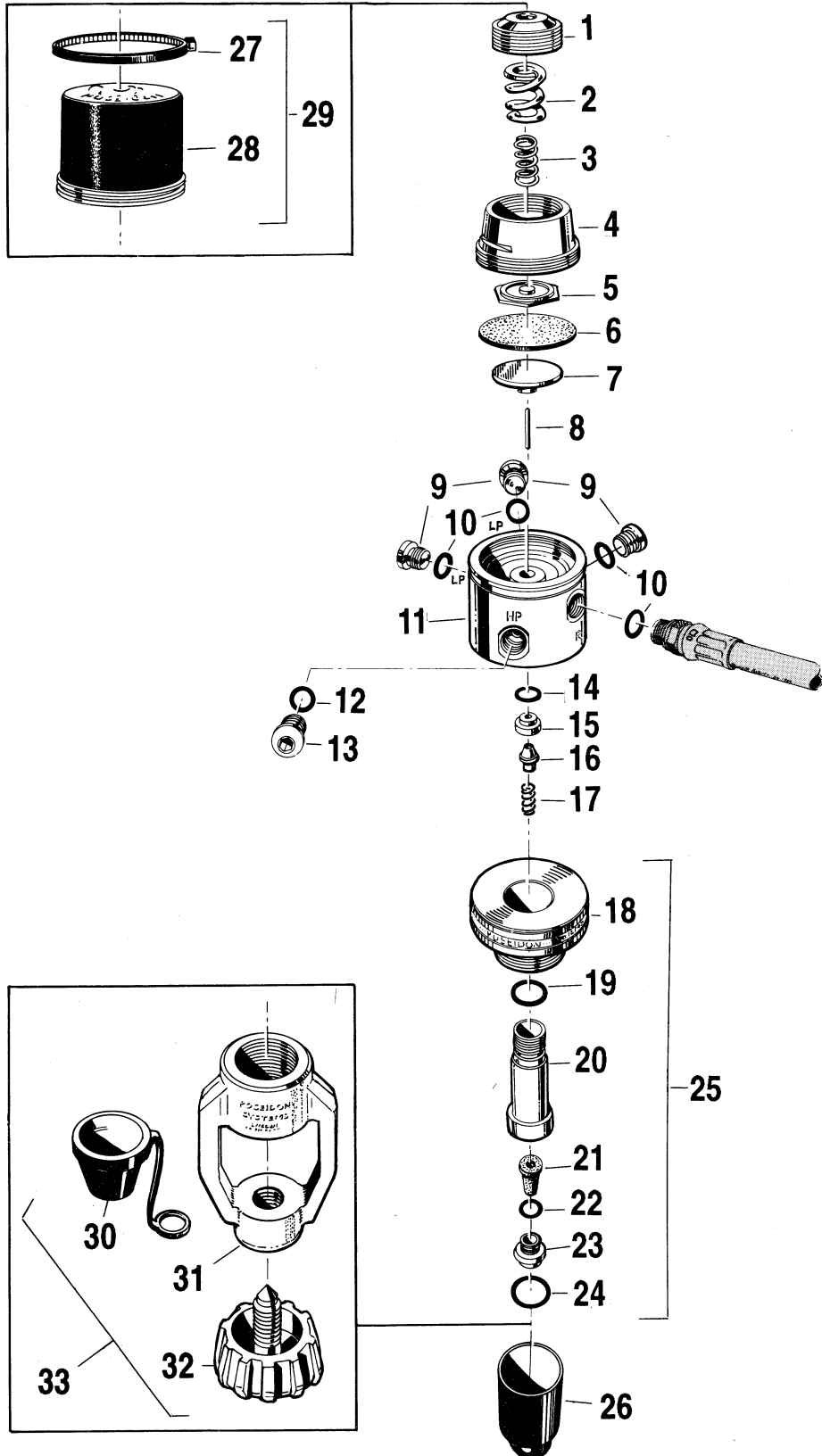

### 3070 First stage, Cyklon 300 and Oceanair (USA=Thor)

Pos.	No.	
1	3417	Pressure adjusting screw
2	2802	Pressure spring, outer
3	3418	Pressure spring, inner
4	2814	Cover for valve housing
5	2815	Diaphragm centre, upper
6	1189	Diaphragm
7	1176	Diaphragm centre, lower
8	2182	Valve needle
9	2679	Blind screw UNF 3/8" (3pcs)
10	2782	O-ring (4st)
11	3023	Valve housing
12	2918	O-ring
13	2680	Blind screw UNF 7/16
14	1156	O-ring
15	2302	Valve seat
16	1179	Valve piston
17	1180	Pressure spring
18	2424	Wheel G5/8"
19	1233	O-ring
20	2423	Connection
21	1377	Cup type filter
22	2656	O-ring
23	3096	Locking screw
24	1007	O-ring
25	2965	Connection incl. 18-24
26	2402	Protective cap
27*	2778	Locking strap
28*	1287	Anti-freeze cap
29*	1286	Anti-freeze cap with locking strap
30*	2277	Protective cap
31*	2921	Yoke
32*	2922	Knob
33*	2920	Yoke complete incl. 30-32

\*Accessories

**3580 First stage, Jetstream**  
**3585 First stage, Cyklon 5000**

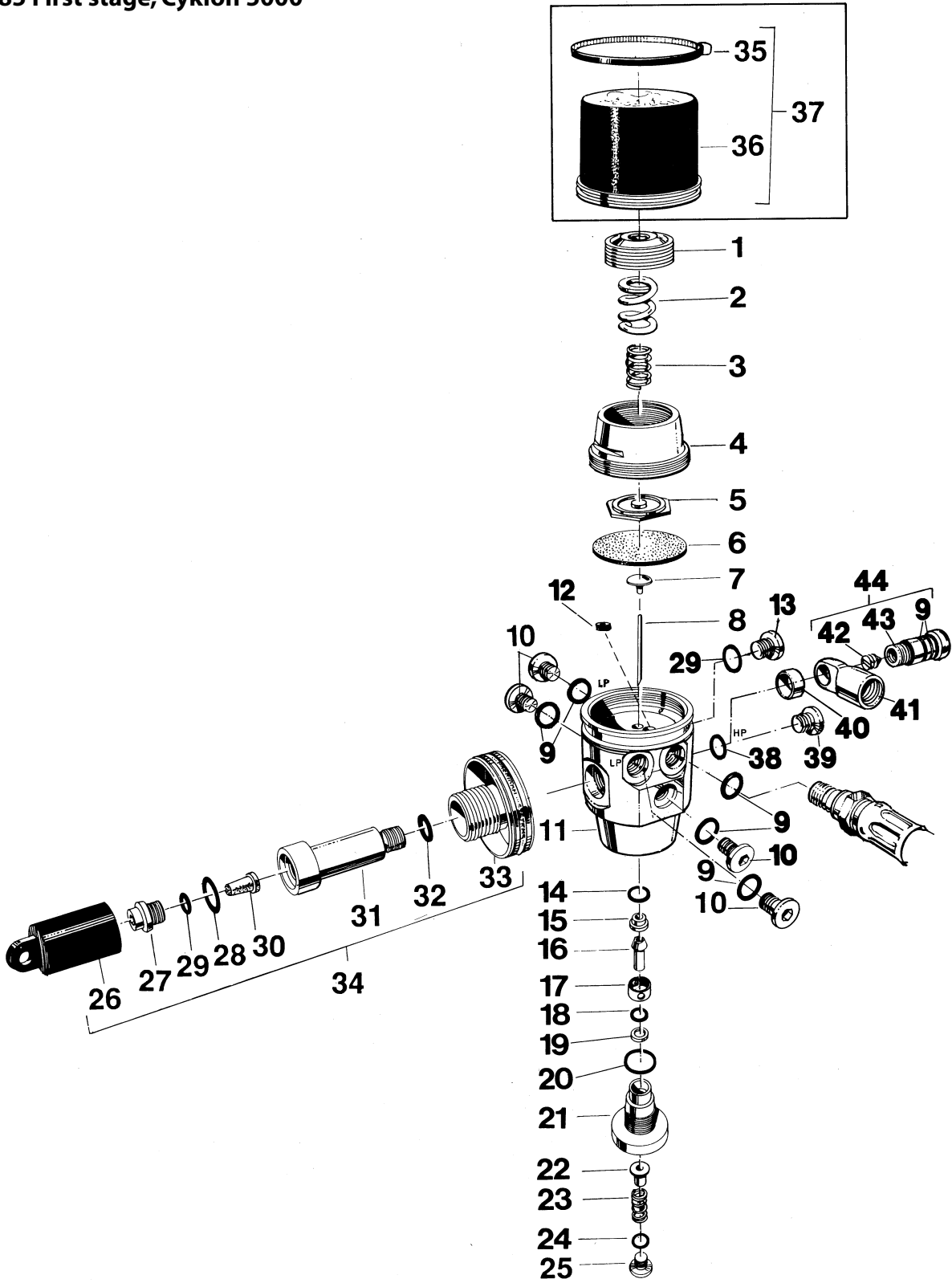

**3580 First stage, Jetstream****3585 First stage, Cyklon 5000**

<b>Pos.</b>	<b>No.</b>				
1	3417	Adjusting screw	38	2918	O-ring
2	2802	Pressure spring, outer	39	2680	Blind screw UNF 7/16"
3	3418	Pressure spring, inner	40	3294	Spacer ring
4	2814	Cover	41	3293	Banjo housing
5	3419	Diaphragm centre, upper	42	1095	Restrictor screw
6	1189	Diaphragm	43	3292	Banjo screw
7	2816	Diaphragm centre, lower	44	3291	Banjo coupling UNF 7/16"
8	2817	Valve needle			incl. 9, 38, 40-43
9	2782	O-ring (7 pcs)			
10	2679	Blind screw UNF 3/8" (4 pcs)			*Accessories
11	3581	Valve housing			
12	3587	Restrictor screw for first stage No. 3585 Cyklon 5000			
13	3024	Blind screw M 7x1			
14	1156	O-ring			
15	2803	Valve seat			
16	2820	Valve piston			
17	2821	Spacing sleeve			
18	1368	O-ring			
19	2822	Washer			
20	2809	O-ring			
21	2823	Balanced housing			
22	3388	Spring guidance			
23	3387	Pressure spring			
24	1562	O-ring			
25	2807	Blind screw G 1/8			
26	2402	Protective cup			
27	3096	Locking screw			
28	1007	O-ring			
29	2656	O-ring (2 pcs)			
30	1377	Cup-type filter			
31	2827	Connection			
32	1839	O-ring			
33	2828	Wheel G 5/8			
34	2966	Connection incl. 27-33			
35	2778	Locking strap*			
36	1287	Anti-freeze cap*			
37	1286	Anti-freeze cap incl. 35-36*			

3580-10 First stage, Jetstream (YOKE)  
 3585-10 First stage, Cyklon 5000 (YOKE)

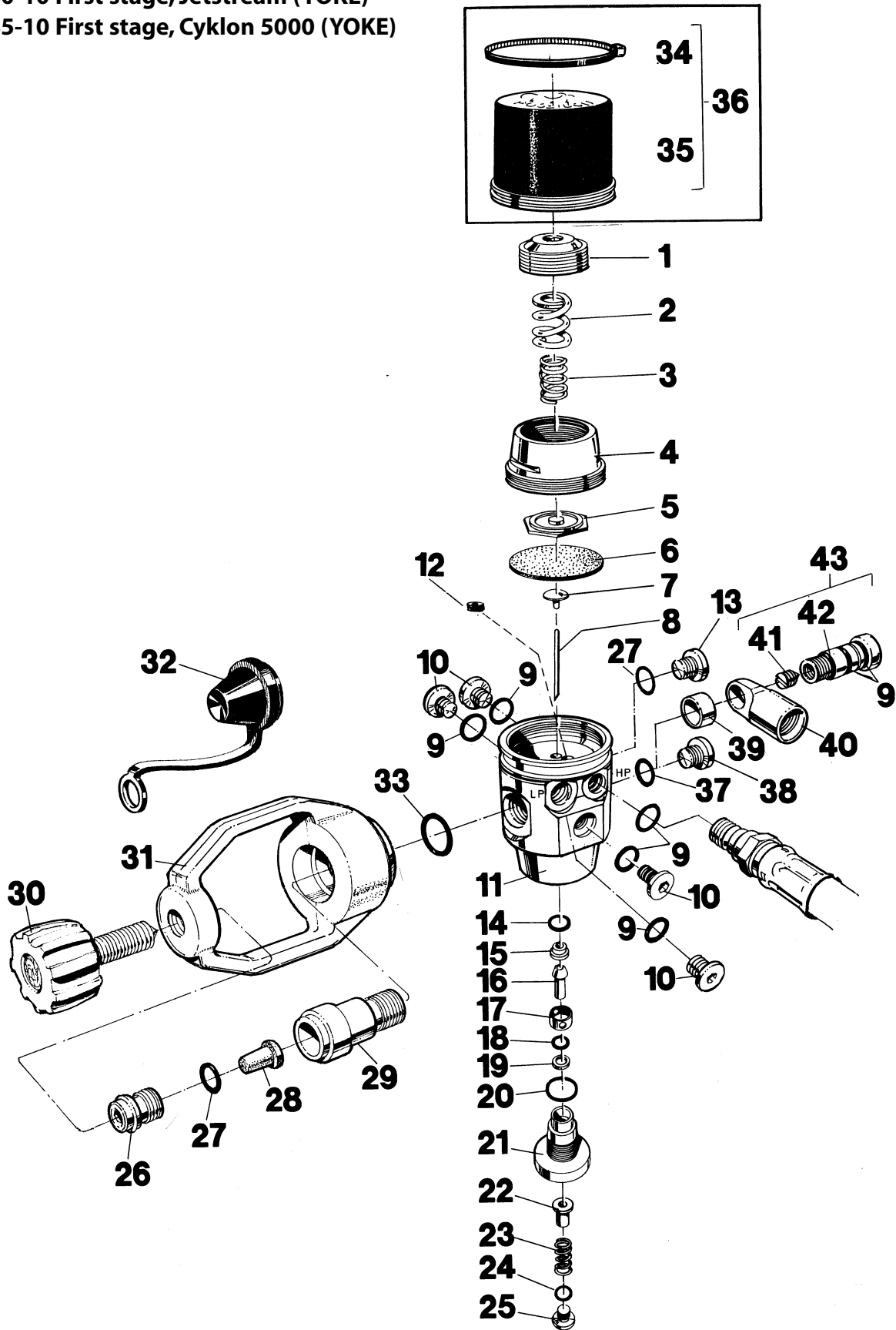

**3580-10 First stage, Jetstream (YOKE)****3585-10 First stage, Cyklon 5000 (YOKE)**

<b>Pos.</b>	<b>No.</b>				
1	3417	Adjusting screw	38	2680	Blind screw UNF 7/16"
2	2802	Pressure spring, outer	39	3294	Spacer ring
3	3418	Pressure spring, inner	40	3293	Banjo housing
4	2814	Cover	41	1095	Restrictor screw
5	3419	Diaphragm, centre, upper	42	3292	Banjo screw
6	1189	Diaphragm	43	3291	Banjo coupling UNF
7	2816	Diaphragm. centre, lower			7/16"incl. 9,37,39-42
8	2817	Valve needle			
9	2782	O-ring (7 pcs)			*Accessories
10	2679	Blind screw UNF 3/8" (4 pcs)			
11	3581	Valve housing			
12	3587	Restrictor screw for first stage No. 3585 10 Cyklon 5000			
13	3024	Blind screw M 7x1			
14	1156	O-ring			
15	2803	Valve seat			
16	2820	Valve piston			
17	2821	Spacing sleeve			
18	1368	O-ring			
19	2822	Washer			
20	2809	O-ring			
21	2823	Balanced housing			
22	3388	Spring guidance			
23	3387	Pressure spring			
24	1562	O-ring			
25	2807	Blind screw G 1/8"			
26	3096	Locking screw			
27	2656	O-ring			
28	1377	Cup-type filter			
29	3472	Connection			
30	2922	Knob			
31	3473	Yoke			
32	2277	Protective cap			
33	1839	O-ring			
34	2778	Locking strap*			
35	1287	Anti-freeze cap*			
36	1286	Anti-freeze cap incl. 34-35*			
37	2918	O-ring			

3790 First stage G 5/8"

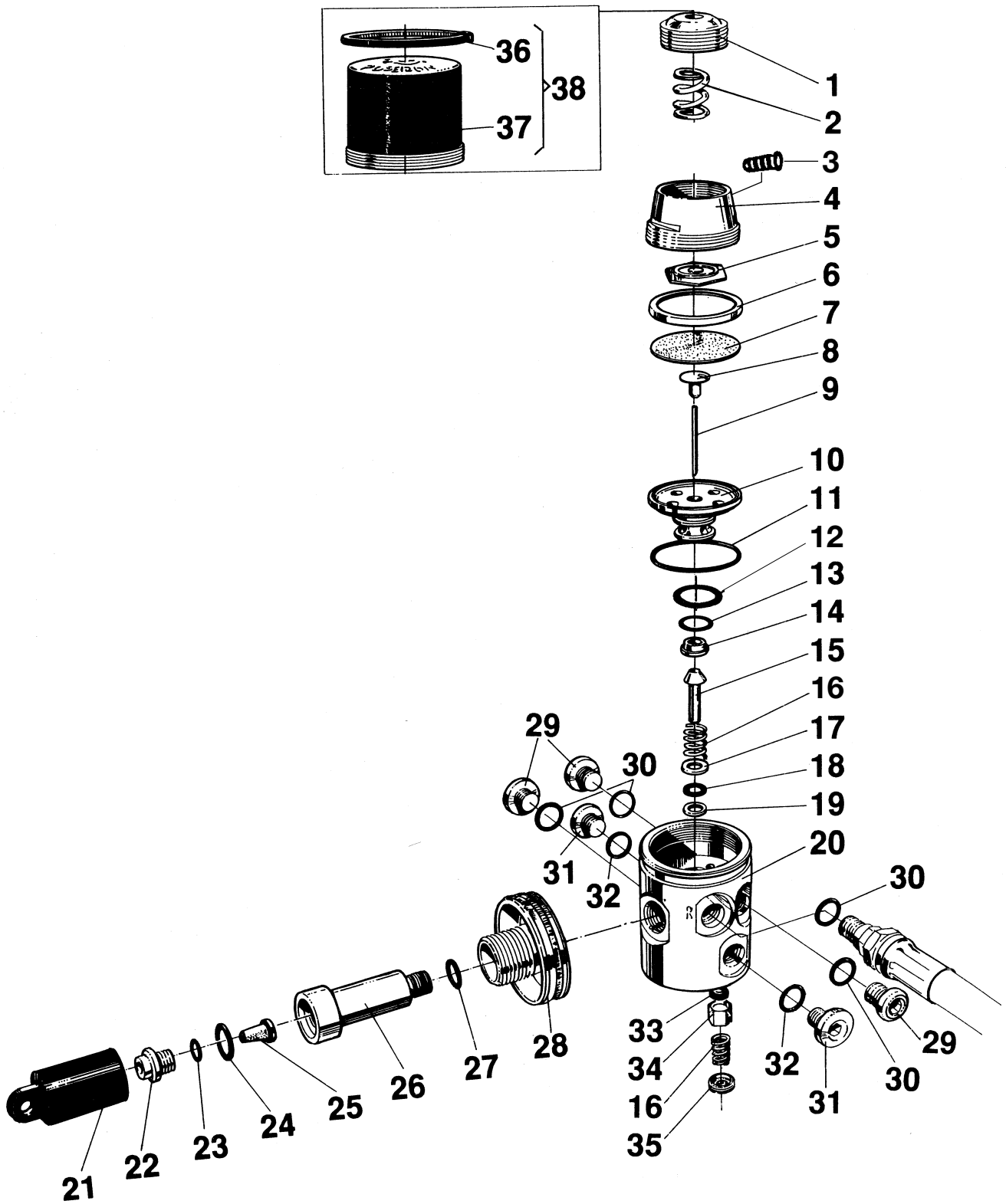

### 3790 First stage G 5/8"

<b>Pos.</b>	<b>No.</b>	<b>Description</b>
1	3417	Adjusting screw
2	2802-10	Pressure spring, outer
3	2875	Stop screw
4	2814	Cover for valve housing
5	3419	Diaphragm centre, upper
6	3723	Valve centre, upper
7	3724	Diaphragm
8	2816	Diaphragm centre, lower
9	2817-10	Valve needle
10	3722	Valve centre, lower
11	3728	O-ring
12	2809	O-ring
13	1156	O-ring
14	2803	Valve seat
15	2820	Valve piston
16	1180	Pressure spring 2 pcs
17	3160	Washer, steel
18	1368	O-ring
19	2822	Washer, teflon
20	3721	Valve housing
21	2402	Protective cap
22	3096	Locking screw
23	2656	O-ring
24	1007	O-ring
25	1377	Cup-type filter
26	2827	Connection
27	1839	O-ring
28	2828	Wheel G 5/8"
29	2679	Blind screw UNF 3/8" (3 pcs)
30	2782	O-ring ( 3 pcs )
31	2680	Blind screw UNF 7/16" (2 pcs)
32	2918	O-ring (2pcs)
33	3726	Valve sealing
34	3725	Valve piston
35	3727	Locking screw
36	2778	Locking strap <sup>1</sup>
37	1287	Anti-freeze cap <sup>1</sup>
38	1286	Anti-freeze cap incl. 36, 37. <sup>1</sup>

1=Accessories



# 3790-10 First stage YOKE

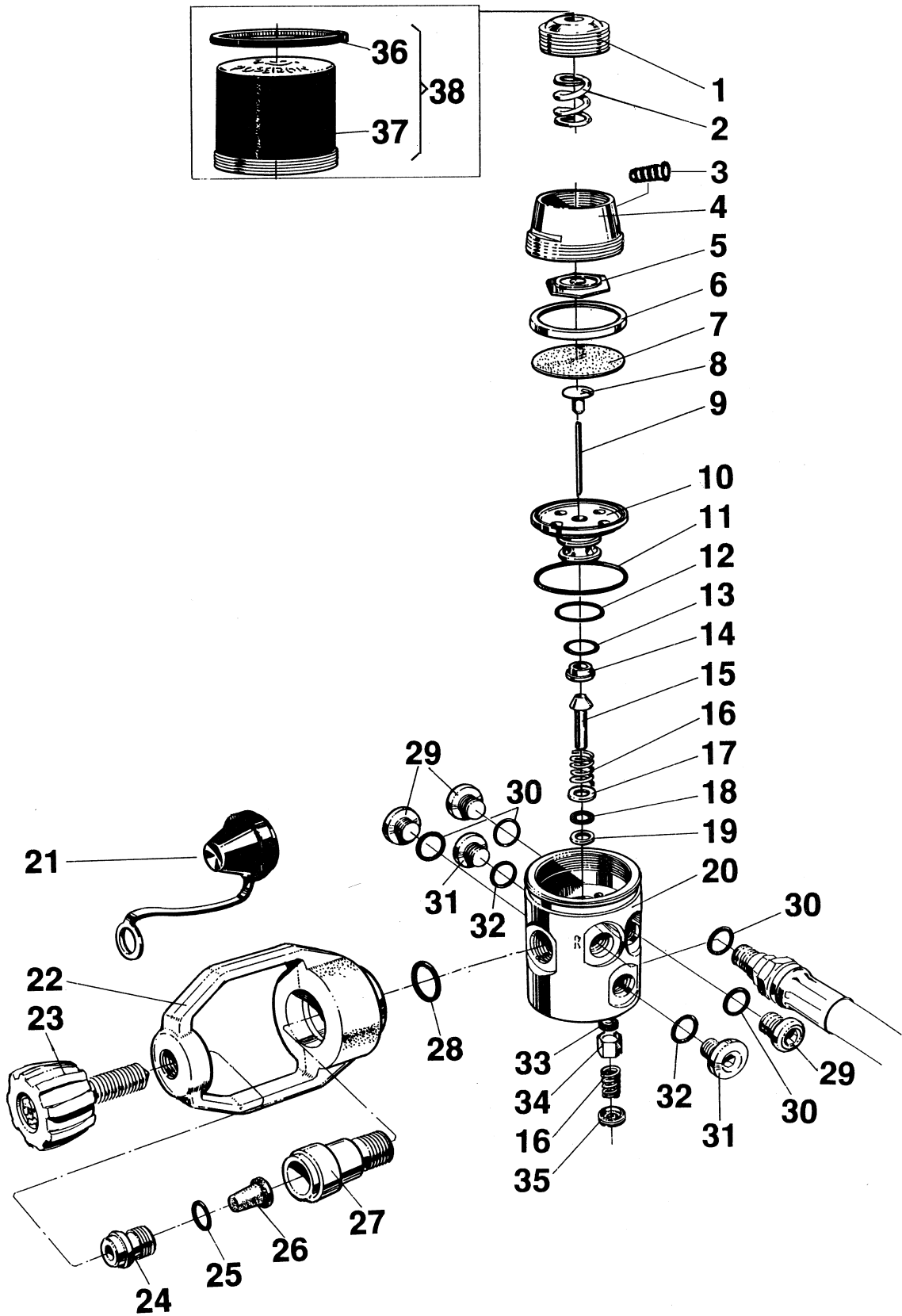

### 3790-10 First stage YOKE

Pos.	No.	Description
1	3417	Adjusting screw
2	2802-10	Pressure spring, outer
3	2875	Stop screw
4	2814	Cover for valve housing
5	3419	Diaphragm centre, upper
6	3723	Valve centre, upper
7	3724	Diaphragm
8	2816	Diaphragm centre, lower
9	2817-10	Valve needle
10	3722	Valve centre, lower
11	3728	O-ring
12	2809	O-ring
13	1156	O-ring
14	2803	Valve seat
15	2820	Valve piston
16	1180	Pressure spring 2 pcs
17	3160	Washer, steel
18	1368	O-ring
19	2822	Washer, teflon
20	3721	Valve housing
21	2277	Protective cap
22	3473	Yoke
23	2922	Yoke screw
24	3096	Locking screw
25	2656	O-ring
26	1377	Cup-type filter
27	3472	Connection
28	1839	O-ring
29	2679	Blind screw UNF 3/8" pcs
30	2782	O-ring ( 3 pcs )
31	2680	Blind screw UNF 7/16" (2 pcs)
32	2918	O-ring (2pcs)
33	3726	Valve sealing
34	3725	Valve piston
35	3727	Locking screw
36	2778	Locking strap <sup>1</sup>
37	1287	Anti-freeze cap <sup>1</sup>
38	1286	Anti-freeze cap incl. 36, 37. <sup>1</sup>

1 = Accessories

3880 First stage G 5/8"

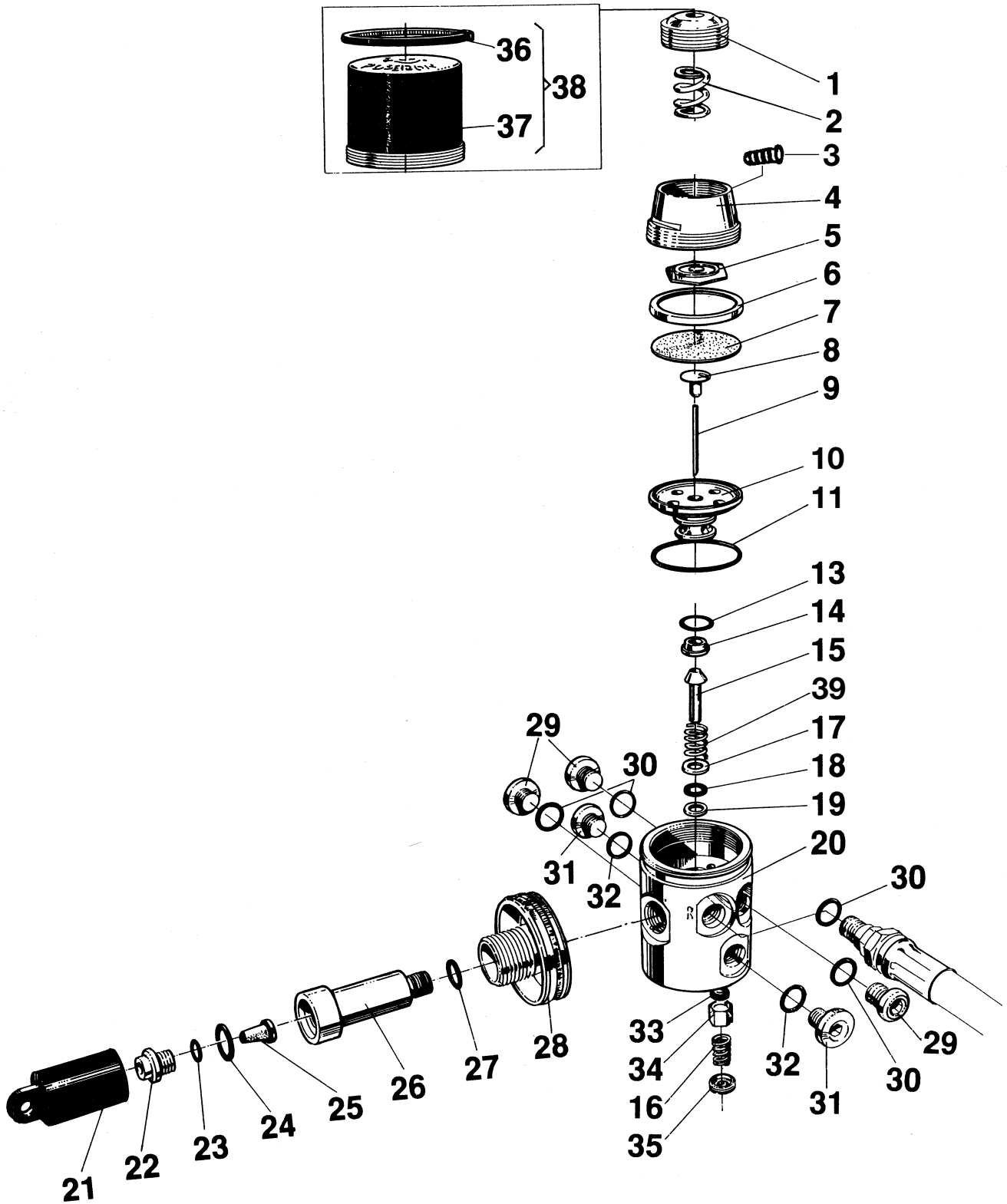

### 3880 First stage G5/8"

<b>Pos.</b>	<b>No.</b>	<b>Description</b>
1	3417	Adjusting screw
2	2802-10	Secondary spring
3	2875	Stop screw
4	2814	Cover for valve housing
5	3419	Upper diaphragm centre
6	3723	Valve centre upper for 3720
7	3724	Diaphragm for 3720
8	2816	Diaphragm centre, lower
9	2817-10	Valve needle (29,5) for 3720
10	3722	Valve centre, lower for 3720
11	3728	O-ring
12	2809	O-ring*
13	1156	O-ring
14	2803	Valve seat
15	2820-10	Valve piston
16	1180	Pressure spring
17	3160	Support washer
18	1368	O-ring
19	2822	Washer
20	3721	Valve housing
21	2402	Protective cap G 5/8"
22	3096	Locking screw
23	2656	O-ring
24	1007	O-ring
25	1377	Cup type filter
26	2827	Connection
27	1839	O-ring
28	2828	Wheel G 5/8"
29	2679	Blind screw 300 bar, UNF 3/8 (3 pcs)
30	2782	O-ring (3 pcs)
31	2680	Blind screw 300 bar, UNF 7/16 (2 pcs)
32	2918	O-ring (2 pcs)
33	3726	Valve sealing
34	3725	Valve piston
35	3727	Locking screw
36	2778	Locking strap <sup>1)</sup>
37	1287	Rubber cap <sup>1)</sup>
38	1286	Anti freeze cap <sup>1)</sup>
39	2923	Pressure spring

<sup>1)</sup>accessories

\* only for first stage 3790

3755 Second stage, black  
3755 30 Second stage, yellow

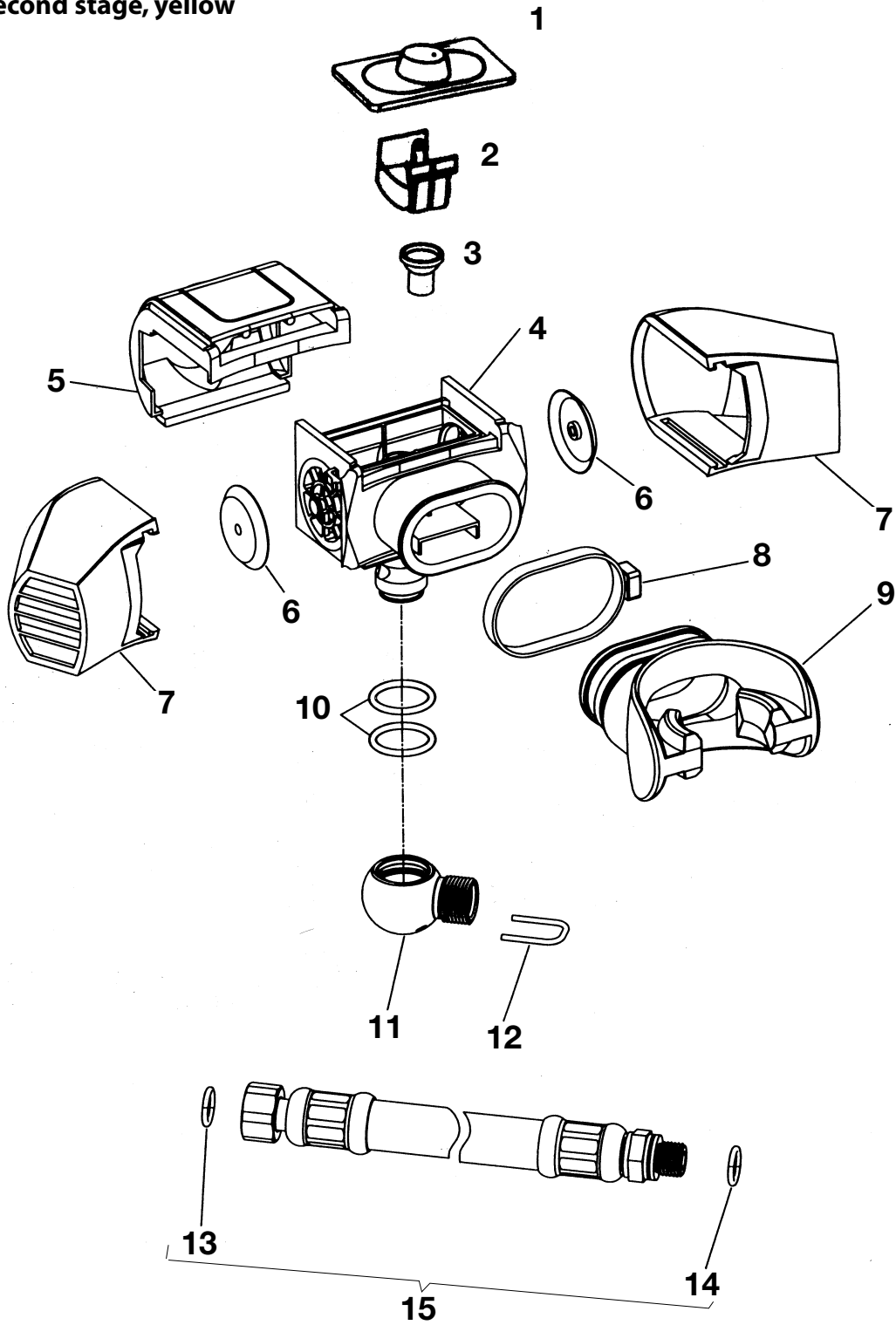

**3755 Second stage, black****3755 30 Second stage, yellow**

<b>Pos.</b>	<b>No.</b>	<b>Description</b>
1	3746	Diaphragm
2	3756	Servo valve
3	3743	Piston
4	3736	Valve housing
5	3738 10	Cover, black
6	3748	Exhaust valve ( 2 pcs )
7	3737 10	Diffuser, black ( 2 pcs )
	3737 30	Diffuser, yellow ( 2 pcs )
8	1167	Locking strap
9	3202	Mouth-piece
10	3734	O-ring (2 pcs)
11	3732	Swivel
12	3733	Securing clip
13	1156	O-ring
14	2782	O-ring
15	3735	Low pressure hose 70cm, incl. 14, 16
	3735 10	Low pressure hose 90cm, incl. 14, 16

**Service kit No 3424  
for breathing regulator JETSTREAM No 2960**

No	pcs	
1167	1	Locking strap
1189	1	Diaphragm
1377	1	Cup-type filter
2787	1	Rubber plate
2803	1	Valve seat
2822	1	Washer
1007	1	O-ring
1145	1	"
1156	1	"
1233	1	"
1368	1	"
1562	1	"
1839	1	"
1896	1	"
2656	2	"
2782	5	"
2809	1	"
2856	1	"
2876	1	"
2918	1	"

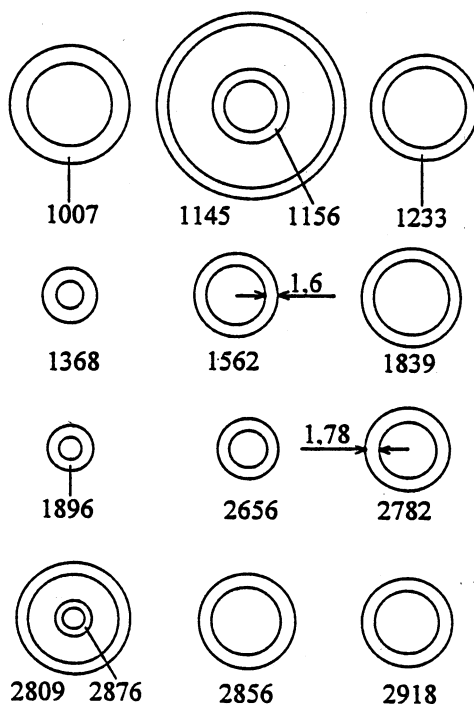

**Service kit No 3827  
for breathing regulator JETSTREAM No 3960**

No	pcs	
1167	1	Locking strap
3724	1	Diaphragm
1377	1	Cup-type filter
2787	1	Rubber plate
2803	1	Valve seat
2822	1	Washer
3726	1	Valve sealing
1007	1	O-ring
1145	1	"
1156	1	"
1233	1	"
1368	1	"
3728	1	"
1839	1	"
1896	1	"
2656	1	"
2782	4	"
2809	1	"
2856	1	"
2876	1	"
2918	2	"

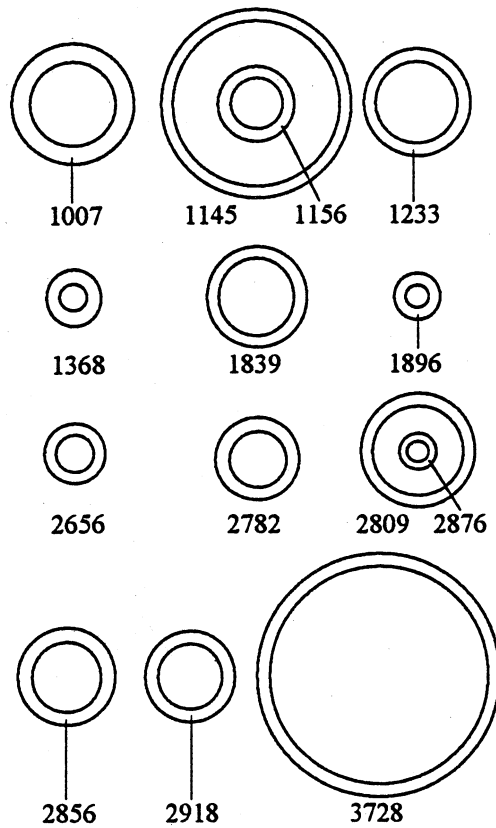



**Service kit No 3423  
for breathing regulator OCEANAIR No 2940**

No	pcs	
1167	1	Locking strap
1189	1	Diaphragm
1377	1	Cup-type filter
2302	1	Valve seat
2787	1	Rubber plate
1007	1	O-ring
1145	1	"
1156	1	"
1233	2	"
1896	1	"
2656	1	"
2782	4	"
2856	1	"
2876	1	"
2918	1	"

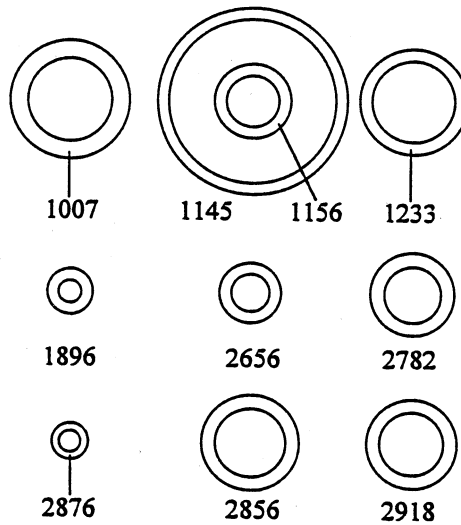

**Service kit No 3430**  
**for breathing regulator CYKLON 300 (G 1/8") No 1908**

No	pcs	
1167	1	Locking strap
1013	4	Gasket
1162	1	Rubber plate
1189	1	Diaphragm
1377	1	Cup-type filter
2302	1	Valve seat
1007	1	O-ring
1145	2	"
1156	2	"
1164	1	"
1233	1	"

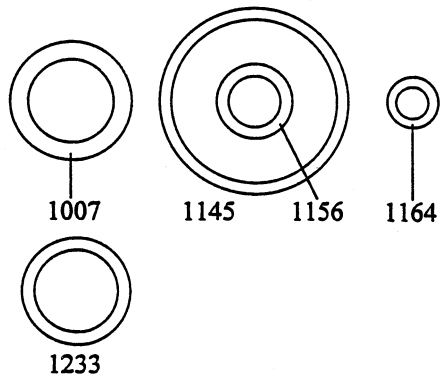

**Service kit No 3824  
for breathing regulator CYKLON 300 (UNF 3/8") No 2980**

No	pcs	
1167	1	Locking strap
1162	1	Rubber plate
1189	1	Diaphragm
1377	1	Cup-type filter
2302	1	Valve seat
1007	1	O-ring
1145	2	"
1156	2	"
1164	1	"
1233	1	"
2656	1	"
2782	4	"
2918	1	"

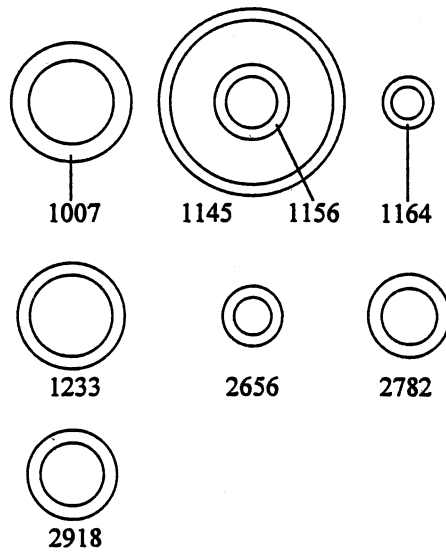

**Service kit No 3422  
for breathing regulator CYKLON 5000 No 2950**

No	pcs	
1167	1	Locking strap
1162	1	Rubber plate
1189	1	Diaphragm
1377	1	Cup-type filter
2803	1	Valve seat
2822	1	Washer
1007	1	O-ring
1145	2	"
1156	2	"
1164	1	"
1368	1	"
1562	1	"
1839	1	"
2656	2	"
2782	5	"
2809	1	"
2918	1	"

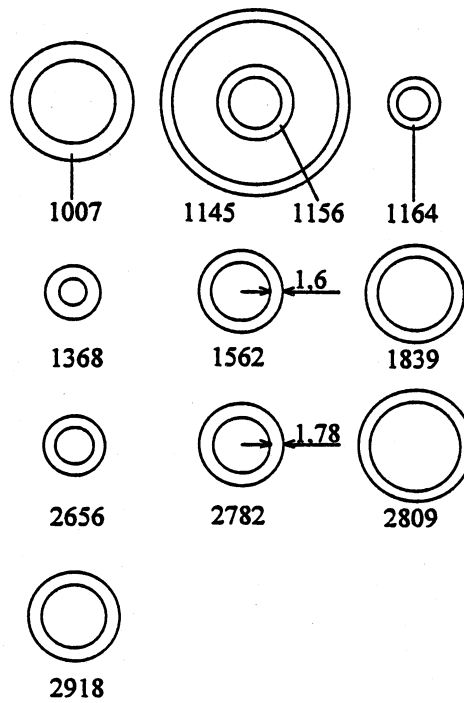

**Service kit No 3825  
for breathing regulator CYKLON 5000 No 3950**

No	pcs	
1167	1	Locking strap
1162	1	Rubber plate
3724	1	Diaphragm
1377	1	Cup-type filter
2803	1	Valve seat
2822	1	Washer
3726	1	Valve sealing
1007	1	O-ring
1145	2	"
1156	2	"
1164	1	"
1368	1	"
3728	1	"
1839	1	"
2656	1	"
2782	4	"
2918	2	"

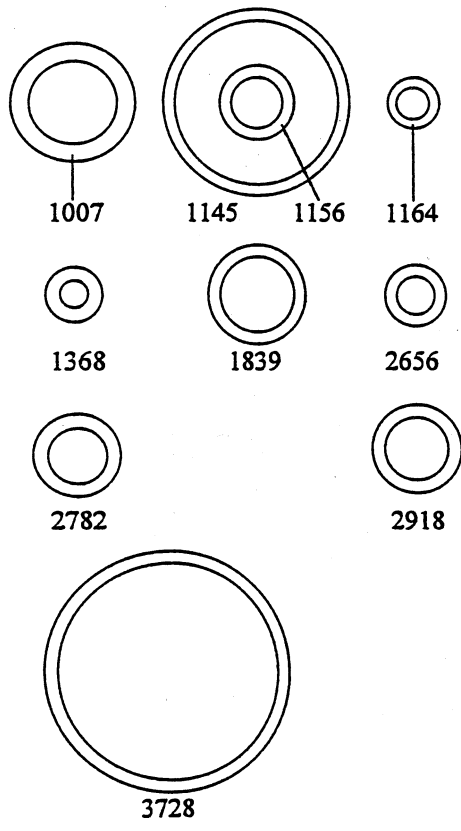

**Service kit No 3769**  
**for first stage No 3720, 3790 and 3880**

No	pcs	
3724	1	Diaphragm
1377	1	Cup-type filter
2803	1	Valve seat
2822	1	Washer
3726	1	Valve sealing
1007	1	O-ring
3728	1	"
1156	1	"
1368	1	"
1839	1	"
2656	1	"
2782	4	"
2809	1	" *
2918	2	"

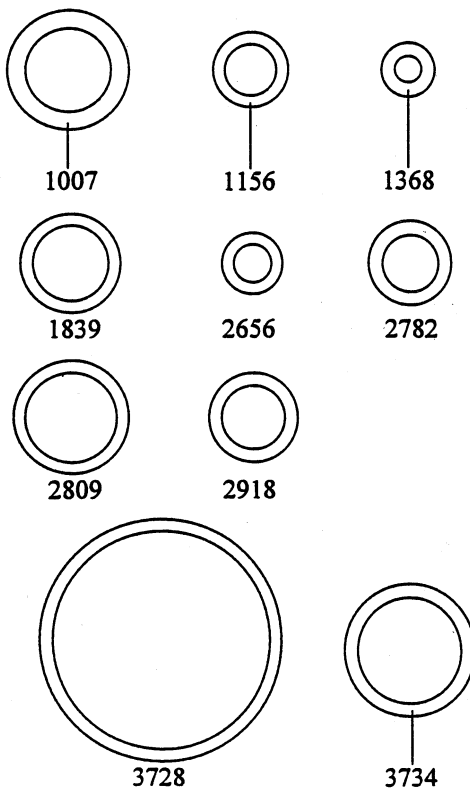

\*Only for first stage No 3790 (Jetstream)

**Service kit No 3872**  
**for first stage No 3720, 3790 and 3880 with O-rings of Viton**

No	pcs	
3724	1	Diaphragm
1377	1	Cup-type filter
2803	1	Valve seat
2822	1	Washer
3726	1	Valve sealing
1007 59	1	O-ring
1156 59	1	"
1368 59	1	"
1839 59	1	"
2656 59	1	"
2782 59	4	"
2809 56	1	" *
2918 59	2	"
3728 59	1	"

\* Only for first stage No 3790

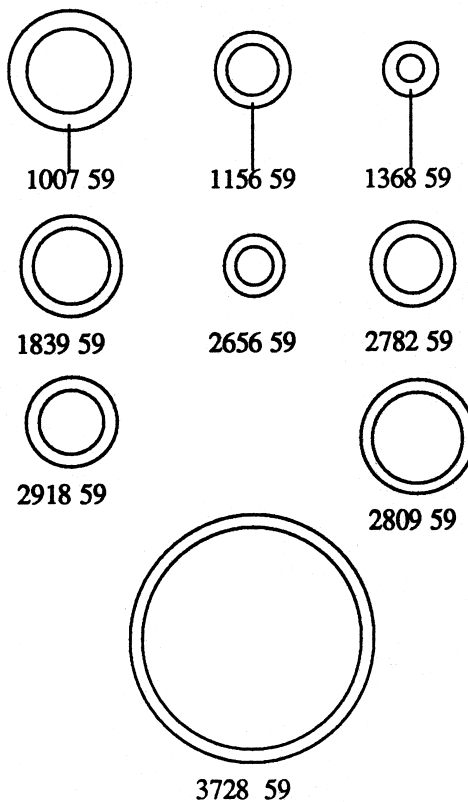

**Service kit No 3826  
for breathing regulator TRITON No 3750**

No	pcs	
1167	1	Locking strap
3724	1	Diaphragm
1377	1	Cup-type filter
2803	1	Valve seat
2822	1	Washer
3726	1	Valve sealing
1007	1	O-ring
3728	1	"
1156	2	"
1368	1	"
1839	1	"
2656	1	"
2782	4	"
3734	2	"
2918	2	"

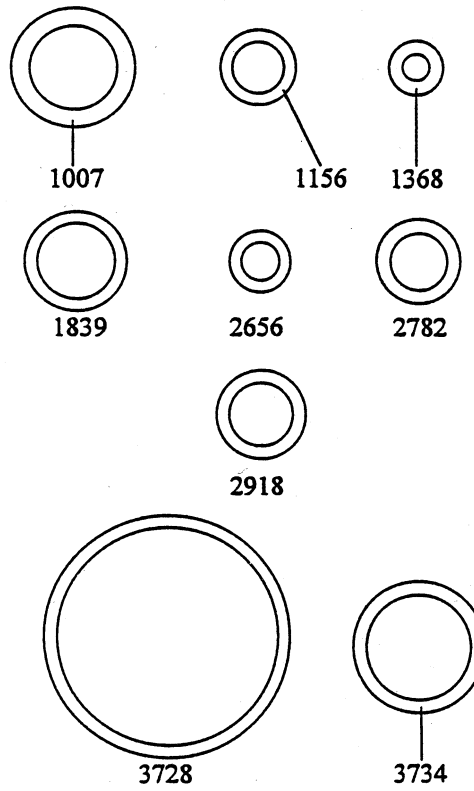



**Service kit No 3549**  
**for second stage Jetstream/Oceanair**

No	pcs	
1167	1	Locking strap
2787	1	Rubber plate
1145	1	O-ring
1233	1	"
1896	1	"
2856	1	"
2876	1	"

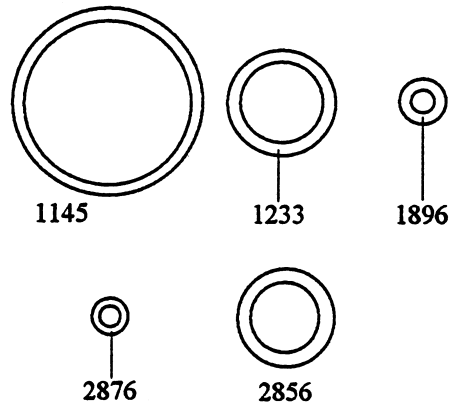

**Service kit No 3551**  
**for second stage Cyklon 300/5000**

No	pcs	
1167	1	Locking strap
1162	1	Rubber plate
1145	2	O-ring
1156	1	"
1164	1	"

